

UNIVERSITY OF CALGARY

Linear Functors and their Fixed Points

by

Masuka Yeasin

A THESIS

SUBMITTED TO THE FACULTY OF GRADUATE STUDIES
IN PARTIAL FULFILLMENT OF THE REQUIREMENTS FOR THE
DEGREE OF MASTER OF SCIENCE

DEPARTMENT OF COMPUTER SCIENCE

CALGARY, ALBERTA

DECEMBER, 2012

© Masuka Yeasin 2012

Abstract

In concurrent programming, message passing along channels plays a key role. This is a form of communication between two processes in which messages can be sent in both directions. To ensure the coherent sequencing of receiving and sending messages the communications on such a channel are governed by a “protocol”.

In this thesis, the categorical semantics of protocols for the message passing logic (introduced by Cockett and Pastro) is introduced. A special class of protocols, built on linear functors, is investigated and it is shown that these protocols naturally form linear functors.

Acknowledgements

My deepest appreciation goes to my supervisor, Dr. Robin Cockett, for giving me enormous support and advice to complete this thesis. It has been a really great experience to work under his supervision.

I would like to thank Robin Cockett, Kristine Bauer, Philip W. L. Fong, and Craig Pastro, for serving on my thesis committee.

I am grateful to Jonathan Gallager, Pavel Hrubes, and Subashis Chakraborty, for proof reading this thesis and giving me valuable suggestions.

Special thanks to my parents, for their support, inspiration, and love.

Table of Contents

Abstract	i
Acknowledgements	ii
Table of Contents	iii
List of Figures	iv
1 Introduction	1
2 Background	6
2.1 Categories	6
2.2 Functors	8
2.3 Natural transformations	10
2.4 Initial and Final Objects	11
2.5 Products and Coproducts	12
2.6 Adjoints	12
2.7 Monoidal Categories	15
2.8 Closed monoidal categories	17
2.9 Linearly distributive categories	17
2.10 Circuit diagrams for linearly distributive categories	24
2.11 Monoidal functors	32
2.12 Circuit diagrams for monoidal functors	33
2.13 Linear functors	36
2.14 Circuit diagrams for linear functors	39
3 Linear Actegories and their Two Actions	42
3.1 Linear Actegories	42
3.2 Circuit diagrams for linear actegories	47
3.3 Actions and linear functors	52
4 Fixed Points of Linear Functors	71
4.1 Algebra definition of inductive and coinductive datatype	71
4.2 Circular definition of inductive and coinductive datatype	75
4.3 Circular rules	78
4.4 Fixed point of a monoidal functor	83
4.5 Fixed point of a linear functor	90
5 Conclusion and Future Work	106
Bibliography	107
A Coherence Conditions for Linear Actegories	110
B Coherence Conditions for Linear Functors	125

List of Figures and Illustrations

2.1	Typed circuit	25
2.2	Circuit composition	26
2.3	Introduction and elimination rules for $\otimes, \oplus, \top, \perp$	27
2.4	Sequentialization Procedure	29
2.5	Reduction, expansion, and equivalence rules for $\otimes, \oplus, \top, \perp$	30
2.6	Circuit diagram for $a_{\otimes} (1 \otimes d_{\oplus}^{\otimes}) d_{\oplus}^{\otimes}$	31
2.7	Circuit diagram for $d_{\oplus}^{\otimes} (a_{\otimes} \oplus 1)$	31
2.8	Simple functor box and monoidal functor box	34
2.9	Box-eats-box rule	35
2.10	Circuit diagrams for m_{\otimes} and m_{\top}	35
2.11	Circuit diagrams for n_{\oplus} and n_{\perp}	36
2.12	Circuit diagrams for $a_{\otimes} (1 \otimes m_{\otimes}) m_{\otimes}$	37
2.13	Circuit diagrams for $(m_{\otimes} \otimes 1) m_{\otimes} F(a_{\otimes})$	37
2.14	Linear functor boxes with monoidal and comonoidal components	39
2.15	Functor boxes for linear strengths	41
3.1	Circuit introduction and elimination rules for \circ	48
3.2	Circuit elimination rule for \bullet	48
3.3	Circuit introduction and elimination rules for $*$	48
3.4	Circuit reduction and expansion rule for \circ	49
3.5	Circuit expansion rule for \bullet	49
3.6	Circuit reduction and expansion rules for $*$	50
3.7	Copy rule	50
3.8	Box-elimination rule	50
3.9	Box-eats-box rule	51
3.10	Circuit diagrams of $a_{\circ}^*, a_{\oplus}^{\bullet}, a_{\bullet}^*$ and a_{\otimes}°	51
3.11	Circuit diagrams of $d_{\oplus}^{\circ}, d_{\otimes}^{\bullet}$, and d_{\bullet}°	52
3.12	Circuit diagram for $(A \circ d_{\otimes}^{\bullet}) d_{\bullet}^{\circ} (B \bullet a_{\otimes}^{\circ})$	53
3.13	Circuit diagram for $a_{\otimes}^{\circ}, d_{\otimes}^{\bullet}$	53
3.14	Defining diagram of m_{\otimes}	54
3.15	Defining diagram of m_{\top}	54
3.16	Validity of $l_{\otimes} = (m_{\top} \otimes 1) m_{\otimes} (A \bullet l_{\otimes})$	55
3.17	Validity of $a_{\otimes} (1 \otimes m_{\otimes}) m_{\otimes} = (m_{\otimes} \otimes 1) m_{\otimes} (A \bullet a_{\otimes})$	56
3.18	Validity of diagram (10) from Figure 3.17	57
3.19	Defining diagram for v_{\oplus}^R	58
3.20	Defining diagram for v_{\otimes}^R	59
3.21	Validity of $l_{\otimes}^{-1} (m_{\top} \otimes 1) v_{\oplus}^R = A \circ l_{\otimes}^{-1}$	61
3.22	Validity of diagram (3) from Figure 3.21	62
3.23	Validity of diagram (11) from Figure 3.21	63
3.24	Validity of $(m_{\otimes} \otimes 1) v_{\oplus}^R (A \circ a_{\otimes}) = a_{\otimes} (1 \otimes v_{\oplus}^R) v_{\oplus}^R$	64

3.25	Circuit Diagram of m_{\otimes} for \bullet	65
3.26	Circuit Diagram for v_{\oplus}^R	66
3.27	Circuit Diagram for $[(m_{\otimes} \otimes 1) v_{\oplus}^R (A \circ a_{\otimes})]$	67
3.28	Circuit Diagram for $[a_{\otimes} (1 \otimes v_{\oplus}^R) v_{\oplus}^R]$	67
3.29	Circuit Diagram for v_{\oplus}^L	68
3.30	Circuit Diagram for $[a_{\otimes} (1 \otimes v_{\oplus}^L) v_{\oplus}^R]$	69
3.31	Circuit Diagram for $[(v_{\oplus}^R \otimes 1) v_{\oplus}^L (A \circ a_{\otimes})]$	70
4.1	$(\vec{m}_{\top} \otimes 1) \vec{m} \vec{F}(l_{\otimes}) = \text{unfold}(g)$	86
4.2	$l_{\otimes} = \text{unfold}(g)$	86
4.3	$a_{\otimes} (1 \otimes \vec{m}) \vec{m} = \text{unfold}(g)$	87
4.4	Validity of diagram (5) from Figure 4.3	88
4.5	$(\vec{m} \otimes 1) \vec{m} \vec{F}(a_{\otimes}) = \text{unfold}(g)$	89
4.6	Validity of equation 4.1	93
4.7	Validity of equation 4.2	94
4.8	Validity of diagram (3) from Figure 4.7	95
4.9	Validity of equation 4.3	99
4.10	Validity of equation 4.4	100
4.11	Validity of equation 4.5	101
4.12	Validity of equation 4.6	102
4.13	Validity of equation 4.7	103
4.14	Validity of diagram (6) from Figure 4.8	104
4.15	Validity of equation 4.8	105

Chapter 1

Introduction

In [22], Milner introduced a process calculus for concurrent communication which provided a calculus for describing communication between processes and relied on the idea of passing messages along channels. A communication channel basically connects two processes and allows both the sending and receiving of messages. While Milner’s notion of communication was non-deterministic so that many processes could potentially communicate on a channel, here we are interested in a deterministic semantics so that a channel will always connect exactly two processes.

The sequencing of sending and receiving and the types of messages which can be sent and received along a channel is determined by a communication protocol. Protocols are, thus, “types” for interaction in the concurrent world. Consider the two processes P and Q , which are connected by a channel: either of the processes can receive or produce a message on the channel. When a protocol is assigned to the channel this determines the sequencing and the types of messages which are allowed to be sent or received on the channel. Thus, a protocol applied to a channel between process P and Q , may require that initially process P should listen for a particular type of message and, thus, dually Q should send a message of this type.

In recent work [17], [25], the notion of a session type has been introduced to govern reciprocal interactions between two processes in a concurrent program. In [18], Honda, Vasconcelos and Kubo described a session type in the context of functional programming language for implementing concurrent communication as a “series of reciprocal interactions between two processes, possibly with branching and recursion and serves as a unit of ab-

straction for describing interaction.” They are, therefore, protocols in the sense described in this thesis.

Linear logic from its inception has been thought to be closely related to concurrent programming. Indeed, when linear logic was first introduced by Girard in [16], he suggested that there should be a link between the connectives of linear logic and concurrent computation. In linear logic, there are two types of propositional connectives: the additives (\times , $+$, 1 and 0) and the multiplicatives (\otimes , \oplus , \top and \perp). The classical conjunction \wedge and its unit \top is divided into the additive categorical product \times with unit 1 and the multiplicative “tensor” \otimes with unit \top respectively while the classical disjunction \vee and its unit \perp is divided into the additive categorical coproduct $+$ and unit 0 and the multiplicative “par” \oplus and unit \perp respectively.

There is a considerable literature concerning the connection between linear logic and the logic of concurrent communication. Abramsky and Jagadeesan [1] proposed a game model for the multiplicative linear logic where games are denoted by formulas and winning strategies are denoted by proofs. From the game semantics view, a formula is represented as a two-player game between “player” and “opponent” and “winning strategies” are proofs of formulas for the player. So the interaction between player and opponent can be thought of as a proof. From the process point of view, player is considered as the “system”, opponent as the “environment” and winning strategies as “deadlock free processes”. From this perspective, a proof can be seen as a process or system that interacts with its environment.

The game model which is described in [1] does not provide a model for concurrent computation as it is only for sequential games which have a fixed interleaving of moves between the player and the opponent. In [2], Abramsky and Mellies introduce a new form of concurrent game semantics by using multiplicative-additive linear logic. In these “concurrent games” both the player and the opponent can play in a distributed and asynchronous manner. How-

ever, there is no explicit notion of protocol or of message passing.

In [20], Joyal studied the free bicompletion of categories, that is categories with free limits and colimits. A special case of this is known as sum-product logic or $\Sigma\Pi$ -logic when the limits are products and the colimits are coproducts. The internal language of a category with free products and coproducts is given by $\Sigma\Pi$ -logic which was studied in [9] by Cockett and Seely: they realized that this logic is just the logic of communication between processes that allows communication only along a single (two-way) channel.

In [24], Pastro extended the $\Sigma\Pi$ -logic to support communication between processes via multiple channels. In [7], Cockett and Pastro introduced the multiplicative-additive linear logic for channel based concurrent communication where simple protocols are attached to each channel. This multiplicative-additive linear logic is represented by linearly distributive categories with additives (sums and products): note that the two tensorial structures \otimes and \oplus allow bundling of channels together. However, in [7] there is no description of how to define general protocols for channels or how a message passing mechanism might work.

In [8], Cockett and Pastro returned to the subject and proposed a model for message passing for concurrency using a two-tier logic. The base tier they called “message logic”, it represents a sequential programming logic, while the tier built on top of message logic is the “message passing logic”, which is a concurrent programming logic. An equivalence is established in [8] between the proof theory, the categorical semantics, and the internal language for this message passing logic.

From the categorical point of view, Cockett and Pastro [8] describe sequential (message) logic as a distributive monoidal category where tensor distributes over coproducts; the concurrent (message passing) logic is then a linear actegory which is defined as a linearly distributive category with a monoidal category acting on it both covariantly and contravariantly. The message passing logic which is developed in [8] can be thought of as a very basic

language for concurrent programs where two or more processes communicate via channels by passing messages. However, general protocols had still not been introduced in [8].

It turns out that even in the concurrent world, categorical initial and final algebras (i.e., inductive and co-inductive data) can be used to express communication protocols in a formal manner. The covariant and contravariant actions together with the additive connectives can be used as the basis for generating protocols as initial and final fixed points. The fact that the coproduct in the sequential world is connected to the additives in the concurrent world allows control dependent on passed messages to transmit into concurrent actions governed by these protocols.

This thesis describes the categorical semantics for message passing and introduces the semantics of protocols as inductive and coinductive concurrent data. The properties of some special protocols that are built on linear functors are then studied. In the concurrent world linear functors play an important role: they provides a basic building block on which one can build initial and final concurrent data or protocols. When data is built on a linear functor, then the initial and final datatypes themselves form a linear functor pair. In this thesis, first it is proven that the two actions from linear actegories give the structure of a parameterized linear functor. Next it is proven that protocols generated by linear functors are themselves a linear functor pair.

Outline of this thesis: Chapter 2 (Section 2.1-2.8) provides the basic definitions from category theory required in this thesis with examples. In Section 2.9, the definition of linearly distributive categories are discussed with examples and Section 2.10 describes the circuit diagrams for linearly distributive categories. Section 2.11 and 2.12 provide the definition of monoidal functors and the circuit representation of these respectively. Linear functors and their circuit diagrams are described in Section 2.13 and 2.14 respectively.

In Chapter 3, linear actegories are defined and a proof of the first main result (Theorem

3.3.2) is given. Section 3.1 provides the definition of linear categories. Section 3.2 presents the circuit diagrams for linear categories and Section 3.3 proves Theorem 3.3.2 which says the actions defined in a linear category have the structure of a parameterized linear functor. To establish this theorem, circuit diagrams are used extensively. Section 3.3 provides the circuit equalities (Figure 3.1-3.9). Chapter 4 is devoted to proving Theorem 4.5.1 which says the fixed point of a linear functor is a linear functor (see Section 4.5). This Chapter also describes the algebraic versus circular definition of initial/inductive and final/coinductive datatype with examples (see Section 4.1-4.2). It turns out that the circular form of the definition is necessary in the concurrent setting in order to capture interaction with channels. Chapter 5 presents conclusion and possible future work.

Contribution of this thesis: In Chapter 3, Theorem 3.3.2 (see Section 3.3) is presented and proved which is new to this thesis. It gives the structure of parameterized linear functor on which initial and final concurrent data i.e., protocols can be built. To prove Theorem 3.3.2, circuit diagrams for linear categories are used. Chapter 4 defines the fixed points of linear functors: these give basic protocols and the definitions of these fixed points is the first presentation of this material. This chapter also shows that the fixed point of a linear functor is a linear functor (Theorem 4.5.1) which is also new to this thesis. This says protocols that are generated by linear functors themselves form linear functors.

Chapter 2

Background

In this chapter, we start by providing some basic definitions from category theory [3], [12] in Section 2.1-2.8. Then we discuss linearly distributive categories [28] in Section 2.9 which are important to this thesis as they form the basis for the categorical semantics of message passing. Section 2.10 provides the circuit representation for linearly distributive categories. As the goal of this thesis is to introduce the semantics of communication protocols, which are built on linear functors, the notion of linear functors [14] is central to the thesis: these are described in Section 2.13. The circuit representation of linear functors are provided in Section 2.14.

2.1 Categories

A **category**, \mathbb{X} , consists of a collection¹ of **objects**, \mathbb{X}_0 , and a collection of **morphisms**, \mathbb{X}_1 , together with:

- For each morphism, $f \in \mathbb{X}_1$, $D_0(f) \in \mathbb{X}_0$ is a **domain** and $D_1(f) \in \mathbb{X}_0$ is a **codomain**. A map f with $D_0(f) = A$ and $D_1(f) = B$ is written as $A \xrightarrow{f} B$. The set of all morphisms from A to B is written as $\text{Hom}(A, B)$ or $\mathbb{X}(A, B)$, and is called the **hom-set** (from A to B).
- For each object $A \in \mathbb{X}_0$, there is an **identity morphism** $1_A : A \rightarrow A$.
- For each pair of maps $A \xrightarrow{f} B$ and $B \xrightarrow{g} C$ where $f, g \in \mathbb{X}_1$, there is a composite, $A \xrightarrow{fg} C$. This data must satisfy (i) Identity: if $f : A \rightarrow B$, then $1_A f = f = f 1_B$ and (ii) Associativity: $f(gh) = (fg)h$.

In a category \mathbb{X} , $A \xrightarrow{f} B$ is an isomorphism if there exists $B \xrightarrow{f^{-1}} A$ such that $ff^{-1} = 1$ and $f^{-1}f = 1$.

Examples:

1. The category, **Set**, is the category whose objects are sets, and morphisms are functions between sets. The composition is the usual composition of functions and identities are identity functions.
2. The category of relations, **Rel**, is a category whose objects are sets and morphisms are relations. If R is a relation on X and Y , and S is a relation on Y and Z then the composition of relations is $RS = \{(x, z) \mid \exists y(x, y) \in R \text{ and } (y, z) \in S\}$. The identity relation on X is $1_X = \{(x, x) \mid x \in X\}$.
3. Given two categories \mathbb{X} and \mathbb{Y} , one can define a product category $\mathbb{X} \times \mathbb{Y}$ whose objects are ordered pairs (X, Y) , where $X \in \mathbb{X}$ and $Y \in \mathbb{Y}$, and morphisms are pairs of morphisms $(f, g) : (X, Y) \rightarrow (X', Y')$, where $f : X \rightarrow X'$ and $g : Y \rightarrow Y'$. Composition of morphisms is componentwise composition, e.g., $(f, g)(f_1, g_1) = (ff_1, gg_1)$, where $(f_1, g_1) : (X_1, Y_1) \rightarrow (X'_1, Y'_1)$. Identities are pairs of identities, e.g., $1_{(X, Y)} = (1_X, 1_Y)$.
4. Suppose \mathbf{R} is a rig (ring without negatives), for example, the natural numbers, \mathbb{N} under addition and multiplication. The category of matrices, **Mat**(\mathbf{R}) is defined as follows:

- Objects: $n \in \mathbb{N}$;
- Morphisms: $(a_{ij})_{nm}$ are $n \times m$ matrices with entries in \mathbf{R} ;

¹Categories which have both objects and maps sets are called *small* categories. However, for example, the category of sets is not small in this sense because the set of all sets is not a set (Russell's paradox). This problem can be surmounted, for example, by allowing *large* categories to have objects to belonging to a "class" while insisting the hom-sets are still sets.

- Composition: Matrix multiplication,

$$(ab)_{ik} = \sum_{j=1}^m a_{ij}b_{jk}$$

- Identities: Identity matrix, δ_{ij} where

$$\delta_{ij} = \begin{cases} 0 & \text{if } i \neq j \\ 1 & \text{if } i = j \end{cases}$$

5. The simplex category, Δ is a category whose objects are finite ordered sets, i.e., isomorphic to $[n] = \{0, \dots, n - 1\}$ and also the empty set \emptyset (where $[0]$ is the empty set), and the morphisms are order preserving maps.

2.2 Functors

Given two categories \mathbb{X} and \mathbb{Y} , a **functor** $F : \mathbb{X} \rightarrow \mathbb{Y}$ is a pair of maps $F_0 : \mathbb{X}_0 \rightarrow \mathbb{Y}_0$ and $F_1 : \mathbb{X}_1 \rightarrow \mathbb{Y}_1$ for which

- if $f : A \rightarrow B$ in \mathbb{X} , then $F_1(f) : F_0(A) \rightarrow F_0(B)$ in \mathbb{Y} ;
- $F_1(1_A) = 1_{F_0(A)}$ for any object A in \mathbb{X} , i.e., functors preserve identities;
- $F_1(fg) = F_1(f) F_1(g)$, i.e., functors preserve composition.

We will generally drop the subscripts from the functor writing $F(f)$ and $F(A)$ instead of $F_1(f)$ and $F_0(A)$ respectively. Small categories and functors form a category called **Cat** whose objects are categories, and morphisms are functors. For a category \mathbb{X} , the identity functor is $1_{\mathbb{X}} : \mathbb{X} \rightarrow \mathbb{X}$ such that for every object A and every morphism f in \mathbb{X} , $1_{\mathbb{X}}(A) = A$ and $1_{\mathbb{X}}(f) = f$. The composition of two functors F and G is $(FG)_i = F_i G_i$. \mathbb{X} and \mathbb{Y} are **isomorphic** when there is an isomorphism $\mathbb{X} \rightarrow \mathbb{Y}$ in **Cat**.

For a category \mathbb{X} , its dual or opposite category is defined as \mathbb{X}^{op} where the objects are the same as \mathbb{X} but a morphism $B \xrightarrow{f} A$ in \mathbb{X}^{op} is $A \xrightarrow{f} B$ in \mathbb{X} . A contravariant functor, F from \mathbb{X} to \mathbb{Y} is $F : \mathbb{X}^{\text{op}} \rightarrow \mathbb{Y}$ where \mathbb{X}^{op} is a dual or opposite category of \mathbb{X} . A covariant functor $F : \mathbb{X} \rightarrow \mathbb{Y}$ is just an ordinary functor.

Examples:

1. The hom-functor is a bi-functor, consisting of a covariant hom-functor and a contravariant hom-functor. Given a category \mathbb{X} with an object X , the **covariant hom functor**, $\mathbb{X}(X, -) : \mathbb{X} \rightarrow \mathbf{Set}$ is defined as: (i) for each object $A \in \mathbb{X}$, $\mathbb{X}(X, -)$ maps A to $\mathbb{X}(X, A)$, the set of morphisms (ii) for any morphism $f : Y \rightarrow Z$, $\mathbb{X}(X, -)$ maps f to the function $\mathbb{X}(X, f) : \mathbb{X}(X, Y) \rightarrow \mathbb{X}(X, Z)$ defined by $g \mapsto gf$ for $g \in \mathbb{X}(X, Y)$. On the other hand, for an object $W \in \mathbb{X}$, the **contravariant hom-functor**, $\mathbb{X}(-, W) : \mathbb{X}^{\text{op}} \rightarrow \mathbf{Set}$ sends an object A to $\mathbb{X}(A, W)$ and a morphism $f : Y \rightarrow Z$ to the $\mathbb{X}(f, W) : \mathbb{X}(Z, W) \rightarrow \mathbb{X}(Y, W)$ given by $g \mapsto fg$ for $g \in \mathbb{X}(Z, W)$. The **hom-functor**, $\mathbb{X}(-, -) : \mathbb{X}^{\text{op}} \times \mathbb{X} \rightarrow \mathbf{Set}$, consists of $\mathbb{X}(X, -)$ and $\mathbb{X}(-, W)$, which maps a pair of objects (X, W) to $\mathbb{X}(X, W)$, and a pair of morphisms, $f : X \rightarrow A$ and $g : Z \rightarrow W$ to $\mathbb{X}(f, g) : \mathbb{X}(A, Z) \rightarrow \mathbb{X}(X, W)$ that sends $h : A \rightarrow Z$ to

$$fhg: \begin{array}{ccc} X & & W \\ f \downarrow & & \uparrow g \\ A & \xrightarrow{h} & Z \end{array}$$

2. The Product functor, $- \times A : \mathbf{Set} \rightarrow \mathbf{Set}$ is defined as

$$- \times A : \mathbf{Set} \rightarrow \mathbf{Set}: \begin{array}{ccc} X & X \times A & (x, a) \\ f \downarrow & \downarrow f \times A & \downarrow \\ Y & Y \times A & (f(x), a) \end{array}$$

3. The list functor, $L : Set \rightarrow Set$ sends a set A to the set of finite sequences whose elements are in A , and extends the maps as

$$\begin{array}{ccc} X & L(X) & [a_1, \dots, a_n] \\ f \downarrow & \mapsto \downarrow L(f) & \downarrow \\ Y & L(Y) & [f(a_1), \dots, f(a_n)] \end{array}$$

2.3 Natural transformations

Given two functors $F, G : \mathbb{X} \rightarrow \mathbb{Y}$, a **natural transformation** $\alpha : F \Rightarrow G$ is a family of morphisms $\alpha_X : F(X) \rightarrow G(X)$, $X \in \mathbb{X}_0$ such that given any morphism $f : X \rightarrow Y$ in \mathbb{X} , the following diagram commute.

$$\begin{array}{ccc} F(X) & \xrightarrow{\alpha_X} & G(X) \\ F(f) \downarrow & & \downarrow G(f) \\ F(Y) & \xrightarrow{\alpha_Y} & G(Y) \end{array}$$

The composition of two natural transformations, $\alpha : F \Rightarrow G$ and $\beta : G \Rightarrow H$ is defined as $(\alpha\beta)_X = \alpha_X\beta_X$

A natural transformation $\gamma : G \Rightarrow F$ is called a **natural isomorphism** if it has an inverse, $\alpha : F \Rightarrow G$. In this case, we say F and G are **isomorphic**.

Examples:

- Given two functors $F, G : \mathbb{X} \rightarrow \mathbb{Y}$, one can define the product of F and G as $F \times G$ such that for each object $A \in \mathbb{X}$, $(F \times G)(A) = F(A) \times G(A)$ and for a morphism $f : A \rightarrow B$, $(F \times G)(f) = F(f) \times G(f)$. Then the projections, $\pi_0 : F(A) \times G(A) \rightarrow F(A)$ and $\pi_1 : F(A) \times G(A) \rightarrow G(A)$ are natural transformations such that the following diagrams commute:

$$\begin{array}{ccc} F(A) \times G(A) & \xrightarrow{\pi_0} & F(A) \\ F(f) \times G(f) \downarrow & & \downarrow F(f) \\ F(B) \times G(B) & \xrightarrow{\pi_0} & F(B) \end{array} \quad \begin{array}{ccc} F(A) \times G(A) & \xrightarrow{\pi_1} & G(A) \\ F(f) \times G(f) \downarrow & & \downarrow G(f) \\ F(B) \times G(B) & \xrightarrow{\pi_1} & G(B) \end{array}$$

2. Constructing a list is a natural transformation. For example, $\text{cons}_A(1, [2, 3]) = [1, 2, 3]$. Moreover,

$$\begin{array}{ccc} A \times L(A) & \xrightarrow{\text{cons}_A} & L(A) \\ f \times L(f) \downarrow & & \downarrow L(f) \\ B \times L(B) & \xrightarrow{\text{cons}_B} & L(B) \end{array}$$

3. Appending a list X to a list Y is a natural transformation. For example,

$$\text{Append}_X([x_1, x_2, \dots, x_n], [y_1, y_2, \dots, y_m]) = [x_1, \dots, x_n, y_1, \dots, y_m].$$

Moreover,

$$\begin{array}{ccc} L(X) \times L(X) & \xrightarrow{\text{Append}_X} & L(X) \\ L(f) \times L(f) \downarrow & & \downarrow L(f) \\ L(Y) \times L(Y) & \xrightarrow{\text{Append}_Y} & L(Y) \end{array}$$

4. Flattening a list of lists is a natural transformation. For example,

$$\text{Flatten}_N([[1], [1, 2], [3, 4, 5]]) = [1, 1, 2, 3, 4, 5].$$

Moreover,

$$\begin{array}{ccc} L(L(X)) & \xrightarrow{\text{Flatten}_X} & L(X) \\ L(L(f)) \downarrow & & \downarrow L(f) \\ L(L(Y)) & \xrightarrow{\text{Flatten}_Y} & L(Y) \end{array}$$

2.4 Initial and Final Objects

An **initial object** in a category \mathbb{X} is an object \emptyset such that for any object $A \in \mathbb{X}$ there is a unique map $? : \emptyset \rightarrow A$. Dually, a **final object** in a category \mathbb{X} is an object 1 such that there is a unique map $! : A \rightarrow 1$ for any object $A \in \mathbb{X}$.

In the category of sets, the initial object is the empty set, \emptyset , and a final object is any one element set.

2.5 Products and Coproducts

Suppose A and B are two objects in a category \mathbb{X} . The **binary product** of A and B is an object $A \times B$ together with morphisms $\pi_0 : A \times B \rightarrow A$ (called the first projection) and $\pi_1 : A \times B \rightarrow B$ (called the second projection) such that for any object D with morphisms $f : D \rightarrow A$ and $g : D \rightarrow B$, there is a unique morphism $\langle f, g \rangle : D \rightarrow A \times B$ that makes the following diagram commute.

$$\begin{array}{ccccc}
 & & D & & \\
 & f \swarrow & \vdots & \searrow g & \\
 & A & \langle f, g \rangle & & B \\
 & \swarrow \pi_0 & \vdots & \searrow \pi_1 & \\
 & & A \times B & &
 \end{array}$$

Given two objects A and B in a category \mathbb{X} then the **coproduct** of A and B is an object $A + B$ together with morphisms $\sigma_0 : A \rightarrow A + B$ (called the first injection) and $\sigma_1 : B \rightarrow A + B$ (called the second injection) such that for any object E with morphisms $f : A \rightarrow E$ and $g : B \rightarrow E$ there is a unique morphism $\langle f | g \rangle : A + B \rightarrow E$ that makes the following diagram commute.

$$\begin{array}{ccccc}
 A & \xrightarrow{\sigma_0} & A + B & \xleftarrow{\sigma_1} & B \\
 & \searrow f & \vdots & \swarrow g & \\
 & & E & &
 \end{array}$$

2.6 Adjoints

Suppose $F : \mathbb{X} \rightarrow \mathbb{Y}$ and $G : \mathbb{Y} \rightarrow \mathbb{X}$ are functors. Then F is a **left adjoint** to G if there is a natural transformation $\eta : X \rightarrow G(F(X))$ such that for any objects $X \in \mathbb{X}$ and $Y \in \mathbb{Y}$ and for any map $f : X \rightarrow G(Y)$, there is a unique map $f^\sharp : F(X) \rightarrow Y$ making the following

triangle commute.

$$\begin{array}{ccc}
 X & \xrightarrow{\eta} & G(F(X)) \\
 & \searrow f & \downarrow G(f^\sharp) \\
 & & G(Y)
 \end{array}$$

This property of η is the **universal mapping property**, and $(F(X), \eta)$ is a **universal pair**. Dually, G is a **right adjoint** to F if there is a natural transformation $\varepsilon : F(G(X)) \rightarrow X$ such that for any objects $X \in \mathbb{X}$ and $Y \in \mathbb{Y}$ and for any map $h : F(X) \rightarrow Y$, there is a unique $h^\flat : X \rightarrow G(Y)$ making the following triangle commute.

$$\begin{array}{ccc}
 & F(X) & \\
 & \downarrow F(h^\flat) & \searrow h \\
 F(G(Y)) & \xrightarrow{\varepsilon} & Y
 \end{array}$$

This property of ε is the **couniversal mapping property**, and $(G(Y), \varepsilon)$ is a **couniversal pair**.

An adjunction $(\eta, \varepsilon) : F \dashv G : \mathbb{X} \rightarrow \mathbb{Y}$ consists of functors $F : \mathbb{X} \rightarrow \mathbb{Y}$ and $G : \mathbb{Y} \rightarrow \mathbb{X}$ and natural transformations $\eta : X \rightarrow G(F(X))$ and $\varepsilon : F(G(X)) \rightarrow X$ with the above universal and couniversal properties.

If $F : \mathbb{X} \rightarrow \mathbb{Y}$ and $G : \mathbb{Y} \rightarrow \mathbb{X}$ are functors with natural transformations η_X and ε_Y that satisfy the following triangle identities, then for any object $X \in \mathbb{X}$, there is a universal pair $(F(X), \eta_X)$ for G at X . This means that an adjunction can be defined as two functors F and G and two natural transformations $\eta_X : X \rightarrow G(F(X))$ and $\varepsilon_Y : F(G(Y)) \rightarrow Y$ called the unit and counit that satisfy the triangle identities.

$$\begin{array}{ccc}
 G(X) \xrightarrow{\eta_{G(Y)}} G(F(G(X))) & & F(X) \xrightarrow{F(\eta_X)} F(G(F(X))) \\
 \parallel & \downarrow G(\varepsilon_Y) & \parallel & \downarrow \varepsilon_{F(X)} \\
 & G(X) & & F(X)
 \end{array}$$

Suppose $F : \mathbb{X} \times \mathbb{Z} \rightarrow \mathbb{Y}$ is a functor and for each $X \in \mathbb{X}$, $F(X, -)$ has a right adjoint $G(X, -)$.

Lemma 1. *If $F : \mathbb{X} \times \mathbb{Z} \rightarrow \mathbb{Y}$ for each $X \in \mathbb{X}$ has a right adjoint such that $(\eta, \varepsilon) : F(X, -) \vdash G(X, -) : \mathbb{Z} \rightarrow \mathbb{Y}$ then $G : \mathbb{X}^{\text{op}} \times \mathbb{Y} \rightarrow \mathbb{Z}$ is a functor where $G(x, y) := (F(x, 1)\varepsilon y)^b$.*

Proof. In order to show that G is a functor, we must show that G preserves identities and composition. Preservation of identities is straightforward. For preservation of composition we have to show that $G(xx', yy') = G(x', y)G(x, y')$.

Given $x : X_0 \rightarrow X_1$, $x' : X_1 \rightarrow X_2$, $y : Y_0 \rightarrow Y_1$ and $y' : Y_1 \rightarrow Y_2$, then

$$\begin{array}{ccccc}
 F(X_0, G(X_2, Y_0)) & \xrightarrow{F(xx', 1)} & F(X_2, G(X_2, Y_0)) & \xrightarrow{\varepsilon} & Y_0 \xrightarrow{yy'} Y_2 \\
 \downarrow F(1, G(xx', yy')) & & & \nearrow \varepsilon & \\
 F(X_0, G(X_0, Y_2)) & & & &
 \end{array}$$

This diagram commutes by the couniversal property of adjunction.

$$\begin{array}{ccccc}
 F(X_0, G(X_2, Y_0)) & \xrightarrow{F(x, 1)} & F(X_1, G(X_2, Y_0)) & \xrightarrow{F(x', 1)} & F(X_2, G(X_2, Y_0)) \\
 \downarrow F(1, G(x', y)) & & \downarrow F(1, G(x', y)) & & \downarrow \varepsilon \\
 & (1) & & (2) & Y_0 \\
 \downarrow F(1, G(x, y')) & & \downarrow F(1, G(x, y')) & & \downarrow y \\
 F(X_0, G(X_1, Y_1)) & \xrightarrow{F(x, 1)} & F(X_1, G(X_1, Y_1)) & \xrightarrow{\varepsilon} & Y_1 \\
 \downarrow F(1, G(x, y')) & & \downarrow F(1, G(x, y')) & & \downarrow y' \\
 F(X_0, G(X_0, Y_2)) & \xrightarrow{\varepsilon} & & & Y_2 \\
 & & (3) & &
 \end{array}$$

In this diagram, (1) commutes because of the functoriality of F , and (2) and (3) commute by the couniversal property of adjunction. This means the composite $G(x', y)G(x, y') = G(xx', yy')$. \square

$G : \mathbb{X}^{\text{op}} \times \mathbb{Y} \rightarrow \mathbb{Z}$ is called the parameterized right adjoint of $F : \mathbb{X} \times \mathbb{Z} \rightarrow \mathbb{Y}$. We note the following important fact about parameterized adjoints:

Corollary 2.6.1. *In a parameterized adjoint, ε is dinatural (and dually, η is dinatural).*

The dinatural diagram is the following special instance of the couniversal property defining $G(x, y)$ above:

$$\begin{array}{ccc}
 F(X_0, G(X_1, Y_0)) & \xrightarrow{F(x,1)} & F(X_1, G(X_1, Y_0)) & \xrightarrow{\varepsilon} & Y_0 \\
 \downarrow & & & \nearrow & \\
 F(1, G(x,1)) & & & \varepsilon & \\
 \downarrow & & & & \\
 F(X_0, G(X_0, Y_0)) & & & &
 \end{array}$$

2.7 Monoidal Categories

A **monoidal category** \mathbb{X} is a category equipped with a bi-functor, the tensor product, $\otimes : \mathbb{X} \times \mathbb{X} \rightarrow \mathbb{X}$, a unit $\top : \mathbb{1} \rightarrow \mathbb{X}$ (where $\mathbb{1}$ is the one-object-one-arrow category), and three natural isomorphisms:

$$a_{\otimes} : (X \otimes Y) \otimes Z \rightarrow X \otimes (Y \otimes Z)$$

$$l_{\otimes} : \top \otimes X \rightarrow X$$

$$r_{\otimes} : X \otimes \top \rightarrow X$$

such that the following two diagrams commute:

$$\begin{array}{ccc}
 (X \otimes \top) \otimes Z & \xrightarrow{a_{\otimes}} & X \otimes (\top \otimes Z) \\
 \searrow r_{\otimes} \otimes 1 & & \swarrow 1 \otimes l_{\otimes} \\
 & X \otimes Z &
 \end{array}$$

$$\begin{array}{ccc}
((X \otimes Y) \otimes Z) \otimes W & \xrightarrow{a_\otimes} & (X \otimes Y) \otimes (Z \otimes W) \\
\downarrow a_\otimes \otimes 1 & & \downarrow a_\otimes \\
(X \otimes (Y \otimes Z)) \otimes W & \xrightarrow{a_\otimes} X \otimes ((Y \otimes Z) \otimes W) \xrightarrow{1 \otimes a_\otimes} & X \otimes (Y \otimes (Z \otimes W))
\end{array}$$

A monoidal category is **symmetric** if there is a natural isomorphism, $c_\otimes : X \otimes Y \rightarrow Y \otimes X$, called the symmetry transformation, such that the following diagrams commute:

$$\begin{array}{ccc}
X \otimes Y & \xrightleftharpoons{1} & X \otimes Y \\
\searrow c_\otimes & & \nearrow c_\otimes \\
& Y \otimes X &
\end{array}
\qquad
\begin{array}{ccc}
X \otimes \top & \xrightarrow{c_\otimes} & \top \otimes X \\
\searrow r_\otimes & & \nearrow l_\otimes \\
& X &
\end{array}$$

$$\begin{array}{ccc}
(X \otimes Y) \otimes Z & \xrightarrow{a_\otimes} X \otimes (Y \otimes Z) \xrightarrow{c_\otimes} & (Y \otimes Z) \otimes X \\
\downarrow c_\otimes \otimes 1 & & \downarrow a_\otimes \\
(Y \otimes X) \otimes Z & \xrightarrow{a_\otimes} Y \otimes (X \otimes Z) \xrightarrow{1 \otimes c_\otimes} & Y \otimes (Z \otimes X)
\end{array}$$

Examples:

1. The category of sets, **Set**, with cartesian product \times is an example of monoidal category. In this case, the unit object is a one element set ,i.e., $1 = \{*\}$ and the tensor is $S \times T = \{(s, t) \mid s \in S \wedge t \in T\}$. In any category with products (or coproducts) the product (or coproduct) always is a symmetric tensor product.
2. The simplex category, Δ , is a non-symmetric monoidal category (as its morphism preserves order) where the tensor product \otimes is addition. For example, $[n] \otimes [m] = [n+m]$, i.e., $[0, 1, \dots, n-1] \otimes [0, 1, \dots, m-1] = [0, 1, \dots, n-1, n, \dots, n+m-1]$. If $f : n \rightarrow n'$ and $g : m \rightarrow m'$ are two morphisms, then we have

$$(f \otimes g)(i) = \begin{cases} f(i) & \text{if } i \in [0, n-1] \\ n' + g(i-n) & \text{if } i \in [n, n+m-1] \end{cases}$$

3. The category of relations, **Rel**, is a monoidal category where disjoint union, \amalg , provides both the product and the coproduct and the cartesian product in **Set** provides a tensor (\otimes) which is neither a product nor a coproduct (See Section 2.1-Examples: 2).

2.8 Closed monoidal categories

Let $A \in \mathbb{X}$. Then $A \otimes _ : \mathbb{X} \rightarrow \mathbb{X}$ is a functor in any monoidal category \mathbb{X} : it takes an object B to $A \otimes B$ and a map $f : B \rightarrow C$ to $A \otimes f : A \otimes B \rightarrow A \otimes C$. Then \mathbb{X} is a **closed monoidal category** if for each object A of \mathbb{X} the functor $A \otimes _$ has a right adjoint.

Equivalently, a monoidal category \mathbb{X} is closed if for two objects A and B , there is an object $A \Rightarrow B$ and a map $\text{ev}_{A,B} : (A \Rightarrow B) \otimes A \rightarrow B$ that satisfy the universal mapping property: for every map $f : X \otimes A \rightarrow B$, there is a unique map $\lambda f : X \rightarrow A \Rightarrow B$ that makes the following diagram commutes.

$$\begin{array}{ccc} X \otimes A & \xrightarrow{\lambda f \otimes 1} & (A \Rightarrow B) \otimes A \\ & \searrow f & \downarrow \text{ev}_{A,B} \\ & & B \end{array}$$

2.9 Linearly distributive categories

Cockett and Seely [28] defined linearly distributive categories which arise from the categorical semantics of multiplicative linear logic [6]. The proof theory of multiplicative-additive linear logic can be described as linearly distributive categories which have products and coproducts

over which the multiplicatives distribute; these have been used to provide a basic setting for communication in the logic [8].

A linearly distributive category is a tuple $(\mathbb{X}, \otimes, \top, \oplus, \perp, d_{\oplus}^{\otimes}, d_{\otimes}^{\oplus})$ such that $(\mathbb{X}, \otimes, \top)$ and $(\mathbb{X}, \oplus, \perp)$ are monoidal. The two monoidal structures, \otimes and \oplus , called “tensor” and “par” respectively, are linked by two linear distributions, d_{\oplus}^{\otimes} and d_{\otimes}^{\oplus} .

$$d_{\oplus}^{\otimes} : X \otimes (Y \oplus Z) \rightarrow (X \otimes Y) \oplus Z$$

$$d_{\otimes}^{\oplus} : (Y \oplus Z) \otimes X \rightarrow Y \oplus (Z \otimes X)$$

A linearly distributive category is symmetric if both the tensor and par are symmetric given by c_{\otimes} and c_{\oplus} respectively. Note that in this case, the following two linear distributions are canonically induced by d_{\oplus}^{\otimes} , d_{\otimes}^{\oplus} , c_{\otimes} , and c_{\oplus} .

$$d_{\oplus}^{\otimes'} : X \otimes (Y \oplus Z) \rightarrow Y \oplus (X \otimes Z)$$

$$d_{\otimes}^{\oplus'} : (Y \oplus Z) \otimes X \rightarrow (Y \otimes X) \oplus Z$$

The above data must obey certain coherence conditions which are as follows:

1. Tensors:

The two tensorial structures, \otimes and \oplus must satisfy the following set of equations:

$$a_{\otimes} (1 \otimes l_{\otimes}) = r_{\otimes} \otimes 1$$

$$a_{\otimes} a_{\otimes} = (a_{\otimes} \otimes 1) a_{\otimes} (1 \otimes a_{\otimes})$$

$$a_{\oplus} (1 \oplus l_{\oplus}) = r_{\oplus} \oplus 1$$

$$a_{\oplus} a_{\oplus} = (a_{\oplus} \oplus 1) a_{\oplus} (1 \oplus a_{\oplus})$$

For the first two equations, the diagrams are in Section 2.7.

2. Units and distributions:

$$\begin{array}{ccc}
 \top \otimes (X \oplus Y) & & (\top \oplus X) \otimes Y \xrightarrow{d_{\otimes}^{\oplus}} \top \oplus (X \otimes Y) \\
 \downarrow d_{\oplus}^{\otimes} & \searrow l^{\otimes} & \downarrow l_{\oplus} \otimes 1 \\
 (\top \otimes X) \oplus Y & \xrightarrow{l_{\otimes} \oplus 1} & X \oplus Y \\
 & & \swarrow l_{\oplus}
 \end{array}$$

The above diagrams generate the following set of equations by using the symmetry:

$$\begin{aligned}
 l_{\otimes} &= d_{\oplus}^{\otimes} (l_{\otimes} \oplus 1) \\
 (l_{\oplus} \otimes 1) &= d_{\otimes}^{\oplus} l_{\oplus} \\
 r_{\otimes} &= d_{\otimes}^{\oplus} (1 \oplus r_{\otimes}) \\
 (1 \otimes r_{\oplus}) &= d_{\oplus}^{\otimes} r_{\oplus} \\
 l_{\otimes} &= d_{\oplus}^{\otimes'} (1 \oplus l_{\otimes}) \\
 r_{\otimes} &= d_{\otimes}^{\oplus'} (r_{\otimes} \oplus 1) \\
 (r_{\oplus} \otimes 1) &= d_{\otimes}^{\oplus'} r_{\oplus} \\
 (1 \otimes l_{\oplus}) &= d_{\oplus}^{\otimes'} l_{\oplus}
 \end{aligned}$$

3. Associativity and distributions:

$$\begin{array}{ccc}
 (X \otimes Y) \otimes (Z \oplus W) & \xrightarrow{a_{\otimes}} & X \otimes (Y \otimes (Z \oplus W)) \\
 \downarrow d_{\oplus}^{\otimes} & & \downarrow 1 \otimes d_{\oplus}^{\otimes} \\
 & & X \otimes ((Y \otimes Z) \oplus W) \\
 & & \downarrow d_{\oplus}^{\otimes} \\
 ((X \otimes Y) \otimes Z) \oplus W & \xrightarrow{a_{\otimes} \oplus 1} & (X \otimes (Y \otimes Z)) \oplus W
 \end{array}$$

The following equations follow from the above diagram:

$$\begin{aligned}
d_{\oplus}^{\otimes} (a_{\otimes} \oplus 1) &= a_{\otimes} (1 \otimes d_{\oplus}^{\otimes}) d_{\oplus}^{\otimes} \\
a_{\otimes} d_{\otimes}^{\oplus} &= (d_{\otimes}^{\oplus} \otimes 1) d_{\otimes}^{\oplus} (1 \oplus a_{\otimes}) \\
d_{\otimes}^{\oplus} a_{\oplus} &= (a_{\oplus} \otimes 1) d_{\otimes}^{\oplus} (1 \oplus d_{\otimes}^{\oplus}) \\
(1 \otimes a_{\oplus}) d_{\oplus}^{\otimes} &= d_{\oplus}^{\otimes} (d_{\oplus}^{\otimes} \oplus 1) a_{\oplus} \\
d_{\oplus}^{\otimes'} (1 \oplus a_{\otimes}) &= a_{\otimes} (1 \otimes d_{\oplus}^{\otimes'}) d_{\oplus}^{\otimes'} \\
a_{\otimes} d_{\otimes}^{\oplus'} &= (d_{\otimes}^{\oplus'} \otimes 1) d_{\otimes}^{\oplus'} (a_{\otimes} \oplus 1) \\
d_{\oplus}^{\otimes'} a_{\oplus} &= (1 \otimes a_{\oplus}) d_{\oplus}^{\otimes'} (1 \oplus d_{\oplus}^{\otimes'}) \\
(a_{\oplus} \otimes 1) d_{\otimes}^{\oplus'} &= d_{\otimes}^{\oplus'} (d_{\otimes}^{\oplus'} \oplus 1) a_{\oplus}
\end{aligned}$$

4. Distributions and distributions:

$$\begin{array}{ccc}
(X \oplus Y) \otimes (Z \oplus W) & \xrightarrow{d_{\otimes}^{\oplus}} & X \oplus (Y \otimes (Z \oplus W)) \\
\downarrow d_{\oplus}^{\otimes} & & \downarrow 1 \oplus d_{\oplus}^{\otimes} \\
((X \oplus Y) \otimes Z) \oplus W & & \\
\downarrow d_{\oplus}^{\otimes} \oplus 1 & & \downarrow \\
(X \oplus (Y \otimes Z)) \oplus W & \xrightarrow{a_{\oplus}} & X \oplus ((Y \otimes Z) \oplus W)
\end{array}$$

The different forms of this diagram generate the following equations:

$$\begin{aligned}
d_{\oplus}^{\otimes} (d_{\otimes}^{\oplus} \oplus 1) a_{\oplus} &= d_{\otimes}^{\oplus} (1 \oplus d_{\oplus}^{\otimes}) \\
a_{\otimes} (1 \otimes d_{\otimes}^{\oplus}) d_{\oplus}^{\otimes} &= (d_{\oplus}^{\otimes} \otimes 1) d_{\otimes}^{\oplus} \\
d_{\oplus}^{\otimes'} (d_{\oplus}^{\otimes'} \oplus 1) a_{\oplus} &= d_{\oplus}^{\otimes'} (1 \oplus d_{\oplus}^{\otimes'}) \\
a_{\otimes} (1 \otimes d_{\oplus}^{\otimes'}) d_{\oplus}^{\otimes'} &= (d_{\oplus}^{\otimes'} \otimes 1) d_{\oplus}^{\otimes'}
\end{aligned}$$

5. Coassociativity and distributions:

$$\begin{array}{ccc}
X \otimes ((Y \oplus Z) \oplus W) & \xrightarrow{1 \otimes a_{\oplus}} & X \otimes (Y \oplus (Z \oplus W)) \\
\downarrow d_{\oplus}^{\otimes} & & \downarrow d_{\oplus}^{\oplus'} \\
(X \otimes (Y \oplus Z)) \oplus W & & Y \oplus (X \otimes (Z \oplus W)) \\
\downarrow d_{\oplus}^{\otimes} \oplus 1 & & \downarrow 1 \oplus d_{\oplus}^{\otimes} \\
(Y \oplus (X \otimes Z)) \oplus W & \xrightarrow{a_{\oplus}} & Y \oplus ((X \otimes Z) \oplus W)
\end{array}$$

The following equations are obtained from the above diagram:

$$\begin{aligned}
d_{\oplus}^{\otimes} (d_{\oplus}^{\oplus'} \oplus 1) a_{\oplus} &= (1 \otimes a_{\oplus}) d_{\oplus}^{\oplus'} (1 \oplus d_{\oplus}^{\otimes}) \\
d_{\otimes}^{\oplus'} (d_{\otimes}^{\oplus} \oplus 1) a_{\oplus} &= (a_{\oplus} \otimes 1) d_{\otimes}^{\oplus} (1 \oplus d_{\otimes}^{\oplus'}) \\
a_{\otimes} (1 \otimes d_{\otimes}^{\oplus'}) d_{\oplus}^{\otimes} &= (d_{\oplus}^{\otimes} \otimes 1) d_{\otimes}^{\oplus'} (a_{\otimes} \oplus 1) \\
a_{\otimes} (1 \otimes d_{\otimes}^{\oplus}) d_{\oplus}^{\oplus'} &= (d_{\oplus}^{\oplus'} \otimes 1) d_{\otimes}^{\oplus} (1 \oplus a_{\otimes})
\end{aligned}$$

A linearly distributive category may have, in addition, products and coproducts and these are expected to behave well with respect to the tensor and par. This in the sense that tensor should distribute over coproducts and par should distribute over products. If \mathbb{X} is a linearly distributive category with a binary product, \times , and binary coproduct, $+$, then the following canonical natural transformations exists for any objects X, Y, Z .

$$\begin{aligned}
X \oplus (Y \times Z) &\xrightarrow{\langle 1 \oplus \pi_0, 1 \oplus \pi_1 \rangle} (X \oplus Y) \times (X \oplus Z) \\
X \oplus 1 &\xrightarrow{!} 1 \\
(X \otimes Y) + (X \otimes Z) &\xrightarrow{\langle 1 \otimes \sigma_0, 1 \otimes \sigma_1 \rangle} X \otimes (Y + Z) \\
0 &\xrightarrow{?} X \otimes 0
\end{aligned}$$

We say that \oplus distributes over products when the first two maps are invertible and similarly, \otimes distributes over coproducts iff the second two maps are invertible.

Examples:

1. A monoidal category can be viewed as a degenerated (collapsed) linearly distributive category in the sense that \otimes serves the role of both tensor and par: the linear distributions are then given by associativity.
2. Any distributive lattice is a linearly distributive category where the objects are elements and maps are comparisons. In this case, \otimes is the meet (\wedge) and \oplus is the join (\vee).
3. Any $*$ -autonomous category, as introduced by Michael Barr [4], [5], is a symmetric monoidal category $(\mathbb{X}, \otimes, \top)$ together with a functor $(-)^* : \mathbb{X}^{\text{op}} \rightarrow \mathbb{X}$ such that for every object $X \in \mathbb{X}$, there is a natural isomorphism $X \cong X^{**}$ and $(X \otimes Y) \cong (X \Rightarrow Y^*)^*$. Moreover, a $*$ -autonomous category, \mathbb{X} is also a symmetric monoidal category $(\mathbb{X}, \oplus, \perp)$ where $(X \oplus Y) \cong (X^* \otimes Y^*)^* \cong X^* \Rightarrow Y$ and there is a following one-to-one correspondence:

$$\frac{X \otimes Y \longrightarrow Z}{Y \longrightarrow X^* \oplus Z}$$

The unit for \oplus is \top^* which can be denoted as \perp such that $X \oplus \perp = (X^* \otimes \perp^*)^* \cong (X^* \otimes \top)^* \cong X^{**} \cong X$.

The above has all the linear distributions of linearly distributive categories. Consider the linear distribution, $d_{\oplus}^{\otimes} : X \otimes (Y \oplus Z) \rightarrow (X \otimes Y) \oplus Z$. We want to show that this linear distribution is present. From closedness, we have:

$$\frac{X \longrightarrow Y \oplus Z}{X \otimes Z^* \longrightarrow Y}$$

Then we can derive $X \otimes (Y \oplus Z) \rightarrow (X \otimes Y) \oplus Z$ as follows:

$$\frac{\frac{Y \oplus Z \rightarrow Y \oplus Z}{(Y \oplus Z) \otimes Z^* \rightarrow Y} \quad \frac{X \otimes Y \rightarrow X \otimes Y}{Y \rightarrow X^* \oplus (X \otimes Y)}}{\frac{(Y \oplus Z) \otimes Z^* \rightarrow X^* \oplus (X \otimes Y)}{X \otimes (Y \oplus Z) \otimes Z^* \rightarrow X \otimes Y}} \\ \frac{X \otimes (Y \oplus Z) \otimes Z^* \rightarrow X \otimes Y}{X \otimes (Y \oplus Z) \rightarrow (X \otimes Y) \oplus Z}$$

The category of relations, **Rel**, and the category of vector spaces, **Vect** are examples of *-autonomous categories. In **Rel**, $X^* = X$ and $\otimes = \oplus = \times$. In **Vect**, $\otimes = \oplus$ and X^* is a dual vector space.

4. The category of sets with a relation, **SetRel**, is an example of a (non-symmetric) linearly distributive category. In this category, an object is a set with a relation, e.g., (X, R) where $R \subseteq X \times X$ and a morphism for two sets X and Y with two relations R and S is $(X, R) \xrightarrow{\alpha} (Y, S)$, i.e., $xRy \implies \alpha(x)R\alpha(y)$. Here, the tensor, \otimes is defined as $(X, R) \otimes (Y, S) = (X \amalg Y, R \amalg S)$, e.g.,

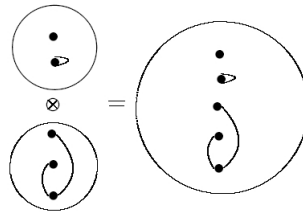

and the par, \oplus is defined as $(X, R) \oplus (Y, S) = (X \amalg Y, X \times Y \cup (R \amalg S))$, e.g.,

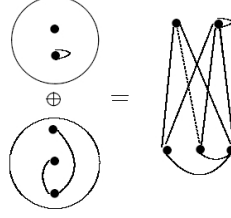

The units for the two tensors (\otimes and \oplus) are the same, i.e., $\top = \perp = (\emptyset, \emptyset)$.

To see that linear distributions hold, consider the linear distribution, $d_{\oplus}^{\otimes} : X \otimes (Y \oplus Z) \rightarrow (X \otimes Y) \oplus Z$.

$$\begin{aligned} X \otimes (Y \oplus Z) &= X \otimes (Y \amalg Z, Y \times Z \cup (R_2 \amalg R_3)) \\ &= (X \amalg (Y \amalg Z), R_1 \amalg (Y \times Z \cup (R_2 \amalg R_3))) \end{aligned}$$

$$\begin{aligned} (X \otimes Y) \oplus Z &= (X \amalg Y, R_1 \amalg R_2) \oplus Z \\ &= ((X \amalg Y) \amalg Z, (X \amalg Y) \times Z \cup (R_1 \amalg R_2 \amalg R_3)) \end{aligned}$$

Here, $X \amalg (Y \amalg Z) \subseteq (X \amalg Y) \amalg Z$. So now we have to check that $R_1 \amalg (Y \times Z \cup (R_2 \amalg R_3)) \rightarrow (X \amalg Y) \times Z \cup (R_1 \amalg R_2 \amalg R_3)$. As $A \amalg (B \cup C) \subseteq B \cup (A \amalg C)$, so we can write $R_1 \amalg (Y \times Z \cup (R_2 \amalg R_3)) \rightarrow Y \times Z \cup (R_1 \amalg R_2 \amalg R_3)$. Then by applying second injection, $\sigma_1 : Y \rightarrow X \amalg Y$, we get $(X \amalg Y) \times Z \cup (R_1 \amalg R_2 \amalg R_3)$. Thus, linear distributions hold which satisfy all the coherence conditions. **SetRel** is a mix category [?] as $\perp = \top$. So it is rather special linearly distributive category.

2.10 Circuit diagrams for linearly distributive categories

Joyal and Street used string diagrams [21] to express maps in tensor categories and in [6] this was developed further to express the connection between proof theory and linearly

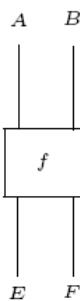

Figure 2.1: Typed circuit

distributive categories. A typed circuit is constructed from a set of types and a set of components. A component is a black box which has a number of typed input and output ports to which variables or wires are attached to connect these components together. The wires must have the same type as the ports which they connect. Figure 2.1 shows an example of a typed circuit in which a component f has two input ports of type A and B respectively and two output ports of type E and F respectively. Attached to the input ports are wires X_1 and X_2 (of type A and B respectively), attached to the output ports are wires Z_1 and Z_2 (of type E and F respectively). The circuit expression is then written as $[X_1, X_2]f[Z_1, Z_2]$.

Two circuit expressions can be plugged together to form a new circuit expression: this is indicated by juxtaposing the expressions. For example, $[X_2, X_3]f[Y_1, Z_1, Y_5, Z_2][X_1, Z_2, X_4, Z_1]g[Y_2, Y_3, Y_4]$ is the circuit shown in Figure 2.2; this is a “non-planar” circuit as there are crossing wires. In a “planar” circuit, wires are not allowed to cross.

Circuits for linearly distributive categories, which have two tensorial structures, \otimes and \oplus , were introduced in [5]. These circuits are constructed from components \mathbf{S} , as discussed above, with ports typed by positive multiplicative linear formulae based on a set of atomic types \mathbf{P} . These formulae may be defined as: (i) A is a formula such that $A \in \mathbf{P}$, (ii) $A \otimes B$ and $A \oplus B$ are formulae if A and B are formulae, and (iii) \top and \perp are formulae.

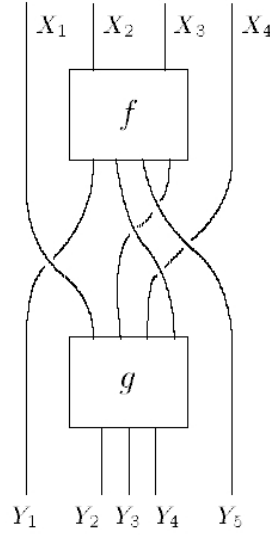

Figure 2.2: Circuit composition

The circuits for linearly distributive categories have special components, called “links” to represent the tensor and par structures [6]. These are:

$[A, B] \otimes I[A \otimes B]$	\otimes -introduction
$[A \otimes B] \otimes E[A, B]$	\otimes -elimination
$[A, B] \oplus I[A \oplus B]$	\oplus -introduction
$[A \oplus B] \oplus E[A, B]$	\oplus -elimination
$[] \top I[\top]$	unit introduction
$[A, \top] \top E[A]$	unit elimination
$[] \perp E[\perp]$	counit introduction
$[A] \perp I[A, \perp]$	counit elimination

The graphical representation of these links are shown in Figure 2.3 where $(\otimes E)$ and $(\oplus I)$ are “switchable” links following Girard. Proof theoretically, the $(\otimes I)$ and $(\otimes E)$ links are introduction and elimination rules for the tensor (\otimes) . Dually, the $(\oplus I)$ and $(\oplus E)$ links are

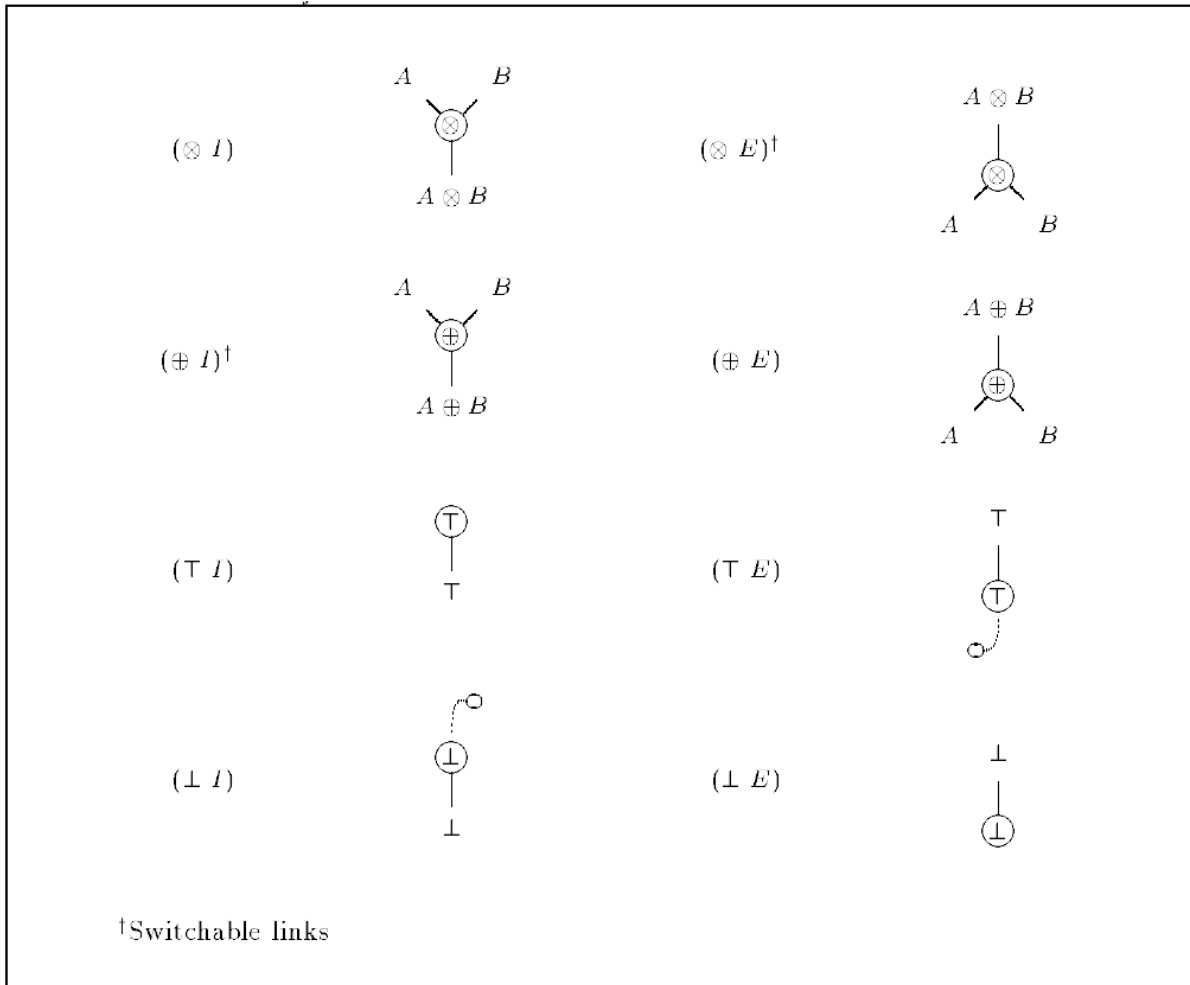

Figure 2.3: Introduction and elimination rules for \otimes , \oplus , \top , \perp

introduction and elimination rules for the cotensor (\oplus).

To build a legal circuit one must construct it following the judgement rules of the type theory which determine what is a valid proof. A criterion for being a legal circuit was introduced by Girard [16]: it says that a circuit is valid if for any choice of “switch settings” for the switchable links the circuit remains acyclic and connected; this means once any switching is chosen there will be exactly one way to get from one component to any other.

However, as a test, Girard’s correctness criterion is not efficient because if the number of

non-switching components is n , then there are 2^n switchings which are possible and have to be tested for acyclicity and connectedness. A more efficient procedure, introduced by Danos and Regnier [15], for determining the validity of a circuit uses “sequentialization”. A circuit with \otimes and \oplus is called sequential if it can be reduced to a single sequent box by applying a series of reduction rules [6]: having such a reduction is equivalent to showing that it is a valid proof. Figure 2.4 shows the sequentialization procedure: the reduction rules allow one to “box” the non-switchings links and components, to combine boxes (cut rule), and to “eat” switching links. In [6], it is shown that a sequential circuit, called a proof net, corresponds to the morphisms of a linearly distributive category.

The determination of the equivalence of proof nets can be organized as a rewriting system in which there are three types of rules: reductions, expansions, and equivalences, shown in Figure 2.5. The reduction rules simplify the circuits while the expansion rules expand wires to “express their type” that is until their type is atomic. The equivalences are concerned with the unit links. All these rewrites are only valid, however, if they transform a legal circuit into a legal circuit.

As there is a correspondence between proof nets and linearly distributive categories, the coherence equations for linearly distributive categories can be represented using proof nets. For example, consider the coherence equation for linearly distributive categories which is $a_{\otimes} (1 \otimes d_{\oplus}^{\otimes}) d_{\oplus}^{\otimes} = d_{\oplus}^{\otimes} (a_{\otimes} \oplus 1)$. Then the validity of this equation can be obtained by using the reduction and expansion rules of (\otimes, \oplus) -circuits which are discussed in Figure 2.5. We shall use this technique extensively in the sequel. The circuit diagrams for left side and right side of the equation $a_{\otimes} (1 \otimes d_{\oplus}^{\otimes}) d_{\oplus}^{\otimes} = d_{\oplus}^{\otimes} (a_{\otimes} \oplus 1)$ are shown in Figure 2.6 and 2.7 respectively. In Figure 2.6, the elimination rule for \otimes is applied. In Figure 2.7, at first we applied the elimination rule for \oplus then we applied the elimination rule for \otimes . Finally, we get the same resulting circuit diagram from Figure 2.6 and 2.7.

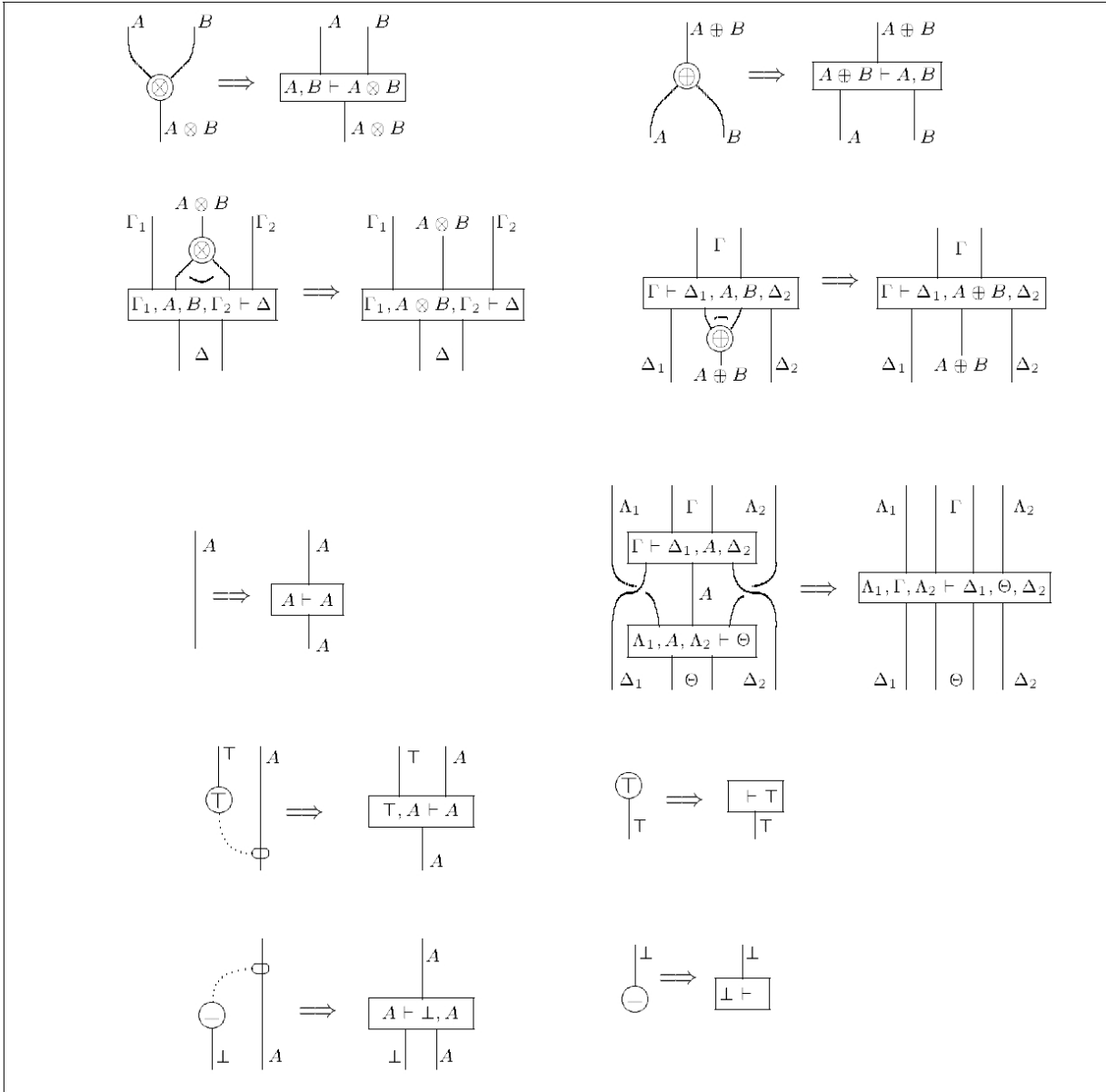

Figure 2.4: Sequentialization Procedure

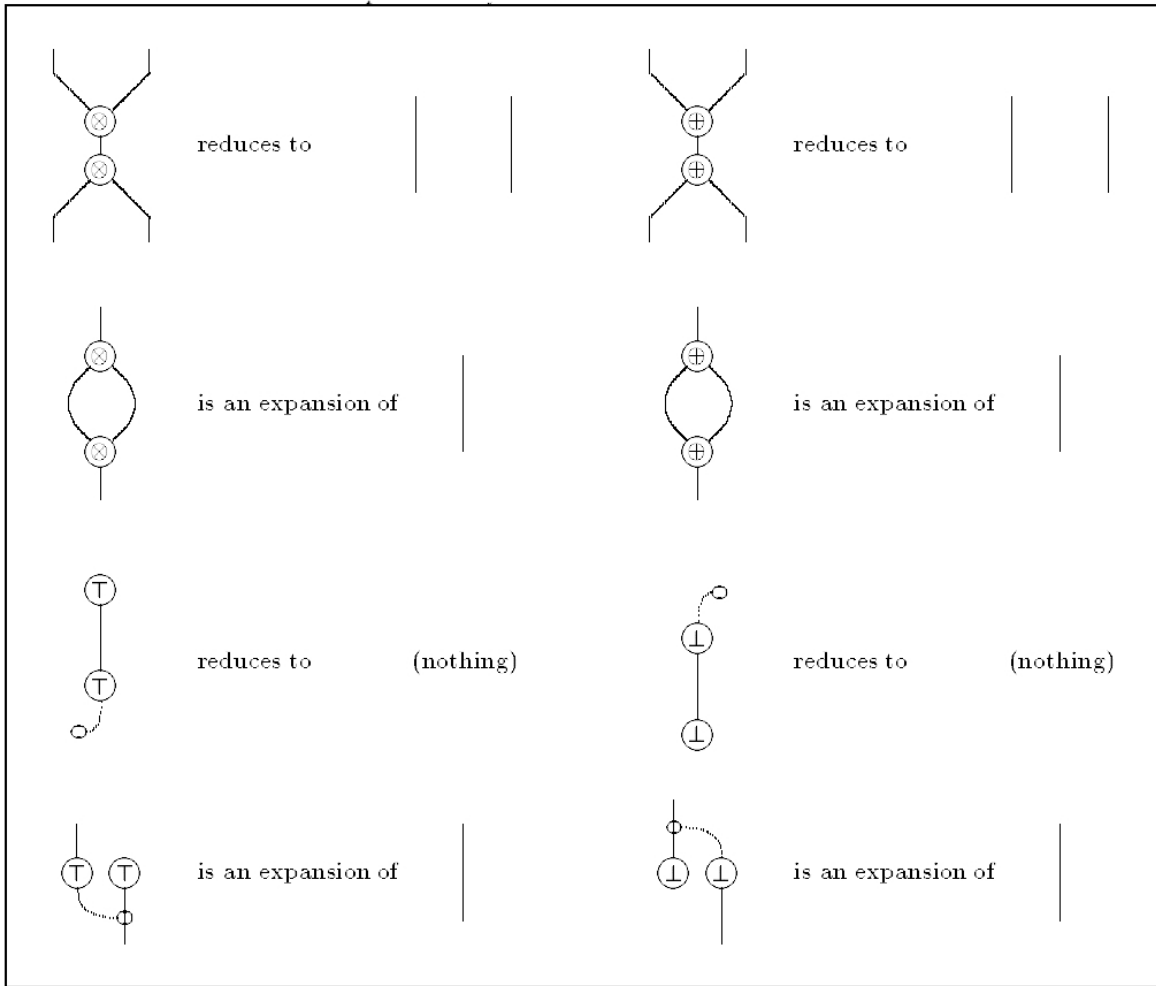

Figure 2.5: Reduction, expansion, and equivalence rules for \otimes , \oplus , \top , \perp

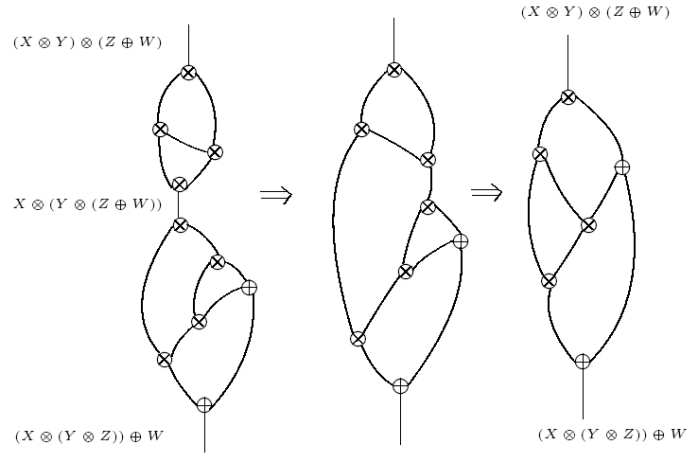

Figure 2.6: Circuit diagram for $a_{\otimes} (1 \otimes d_{\oplus}^{\otimes}) d_{\oplus}^{\otimes}$

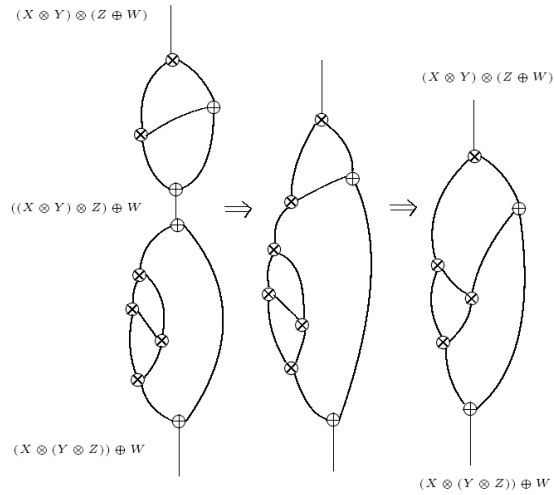

Figure 2.7: Circuit diagram for $d_{\oplus}^{\otimes} (a_{\otimes} \oplus 1)$

2.11 Monoidal functors

Suppose \mathbb{X} and \mathbb{Y} are monoidal categories. A monoidal functor is defined as a functor F between two monoidal categories \mathbb{X} and \mathbb{Y} with two natural transformations:

$$\begin{aligned} m_{\otimes} &: F(A) \otimes F(B) \rightarrow F(A \otimes B) \\ m_{\top} &: \top \rightarrow F(\top) \end{aligned}$$

which must satisfy the following two coherence conditions:

$$\begin{aligned} (m_{\top} \otimes 1) m_{\otimes} F(l_{\otimes}) &= l_{\otimes} \\ a_{\otimes} (1 \otimes m_{\otimes}) m_{\otimes} &= (m_{\otimes} \otimes 1) m_{\otimes} F(a_{\otimes}) \end{aligned}$$

We can also express the above two equations diagrammatically which are as follows:

$$\begin{array}{ccc} \top \otimes F(A) & \xrightarrow{m_{\top} \otimes 1} & F(\top) \otimes F(A) \\ l_{\otimes} \downarrow & & \downarrow m_{\otimes} \\ F(A) & \xleftarrow{F(l_{\otimes})} & F(\top \otimes A) \end{array}$$

$$\begin{array}{ccc} (F(A) \otimes F(B)) \otimes F(C) & \xrightarrow{a_{\otimes}} & F(A) \otimes (F(B) \otimes F(C)) \\ m_{\otimes} \otimes 1 \downarrow & & \downarrow 1 \otimes m_{\otimes} \\ F(A \otimes B) \otimes F(C) & & F(A) \otimes F(B \otimes C) \\ m_{\otimes} \downarrow & & \downarrow m_{\otimes} \\ F((A \otimes B) \otimes C) & \xrightarrow{F(a_{\otimes})} & F(A \otimes (B \otimes C)) \end{array}$$

For a symmetric monoidal functor, there is another coherence condition which must be satisfied.

$$\begin{aligned} m_{\otimes} F(c_{\otimes}) &= c_{\otimes} m_{\otimes} \\ F(A) \otimes F(B) & \xrightarrow{m_{\otimes}} F(A \otimes B) \\ c_{\otimes} \downarrow & & \downarrow F(c_{\otimes}) \\ F(B) \otimes F(A) & \xrightarrow{m_{\otimes}} F(B \otimes A) \end{aligned}$$

Dually, a comonoidal functor, $\bar{F} : \mathbb{X} \rightarrow \mathbb{X}$ is a functor with two natural transformations

$$n_{\oplus} : \bar{F}(A \oplus B) \rightarrow \bar{F}(A) \oplus \bar{F}(B)$$

$$n_{\perp} : \bar{F}(\perp) \rightarrow \perp$$

In this case, the following two coherence conditions must be satisfied.

$$\bar{F}(l_{\oplus}^{-1}) n_{\oplus} (n_{\perp} \oplus 1) = l_{\oplus}^{-1}$$

$$n_{\oplus} (n_{\oplus} \oplus 1) a_{\oplus} = \bar{F}(a_{\oplus}) n_{\oplus} (1 \oplus n_{\oplus})$$

$$\begin{array}{ccc} \bar{F}(A) & \xrightarrow{\bar{F}(l_{\oplus}^{-1})} & \bar{F}(\perp \oplus A) \\ l_{\oplus}^{-1} \downarrow & & \downarrow n_{\oplus} \\ \perp \oplus \bar{F}(A) & \xleftarrow{n_{\perp \oplus 1}} & \bar{F}(\perp) \oplus \bar{F}(A) \end{array}$$

$$\begin{array}{ccc} \bar{F}((A \oplus B) \oplus C) & \xrightarrow{n_{\oplus}} & \bar{F}(A \oplus B) \oplus \bar{F}(C) \\ \bar{F}(a_{\oplus}) \downarrow & & \downarrow n_{\oplus \oplus 1} \\ \bar{F}(A \oplus (B \oplus C)) & & (\bar{F}(A) \oplus \bar{F}(B)) \oplus \bar{F}(C) \\ n_{\oplus} \downarrow & & \downarrow a_{\oplus} \\ \bar{F}(A) \oplus \bar{F}(B \oplus C) & \xrightarrow{1 \oplus n_{\oplus}} & \bar{F}(A) \oplus (\bar{F}(B) \oplus \bar{F}(C)) \end{array}$$

Examples:

- A monoidal functor for which m_{\otimes} and m_{\top} are isomorphisms is said to be a strict monoidal or iso-monoidal functor.
- Any functor between categories with coproducts is monoidal when we regard the tensor as being the coproduct such that for any objects $A \in \mathbb{X}$ and $B \in \mathbb{Y}$, $F(A) + F(B) \xrightarrow{\langle F(\sigma_0) | F(\sigma_1) \rangle} F(A + B)$. Dually any functor between categories with products is comonoidal.

2.12 Circuit diagrams for monoidal functors

Graphically, one may represent functors using functor boxes. Cockett and Seely introduced a calculus of “functor boxes” in [14] to analyze the structure of linear functors (discussed in

the next section) by using circuits. If f is a component that takes an input A and produces an output B , then we can apply a functor box F on the component f . The input of the functor box will be $F(A)$ and the output will be $F(B)$. If f has more inputs then we have to use tensor (\otimes) or par (\oplus) links before applying functor box. Figure 2.8 shows a simple functor box and a monoidal functor box. The wire leaves the functor box through a port which is called principal port and it is denoted by a circle. If we have two functor boxes, then the top box can be pushed down into the bottom box. Figure 2.9 shows this box-eats-box rule.

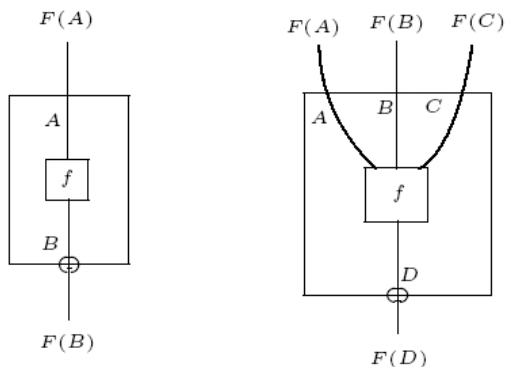

Figure 2.8: Simple functor box and monoidal functor box

For a functor F to be monoidal, we know that there must be two natural transformations m_{\otimes} and m_{\top} . Figure 2.10 shows the circuit diagrams for m_{\otimes} and m_{\top} . For m_{\otimes} , component f is replaced by a link ($\otimes I$) which has two inputs A and B and one output $A \otimes B$ and for m_{\top} , component f is replaced by a link ($\top I$) which has no inputs and one output \top . Similarly for comonoidal functors, the circuit diagrams for n_{\oplus} and n_{\perp} are shown in Figure 2.11 where links ($\oplus E$) and ($\perp E$) are used for n_{\oplus} and n_{\perp} respectively. The principal port is located at the top of the functor box for comonoidal functors to create a distinction between comonoidal and monoidal functors.

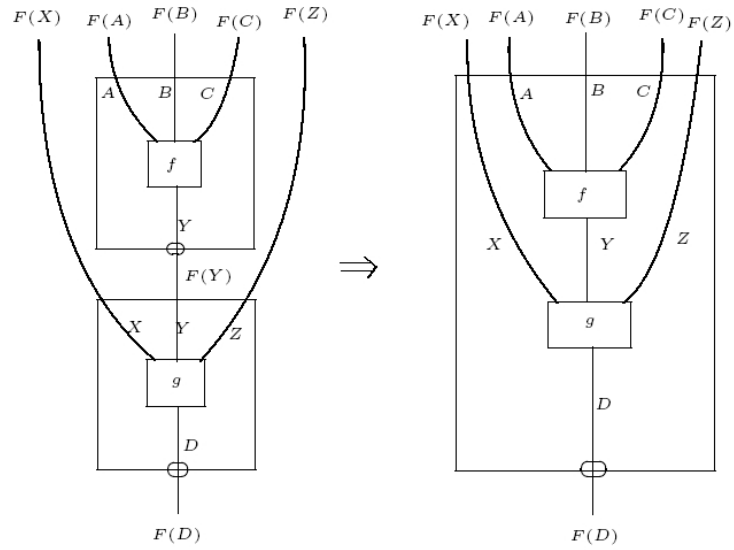

Figure 2.9: Box-eats-box rule

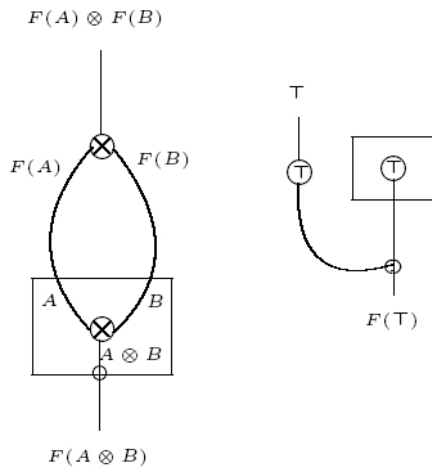

Figure 2.10: Circuit diagrams for m_\otimes and m_\top

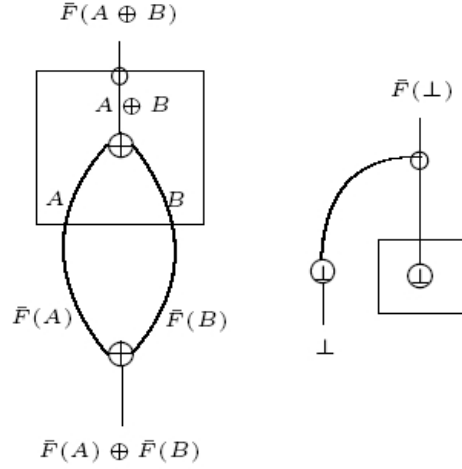

Figure 2.11: Circuit diagrams for n_{\oplus} and n_{\perp}

The coherence conditions for monoidal functors (Section 2.11) can be represented by circuit diagrams. Here one coherence condition is considered which is $a_{\otimes} (1 \otimes m_{\otimes}) m_{\otimes} = (m_{\otimes} \otimes 1) m_{\otimes} F(a_{\otimes})$. The circuit diagrams for the left-side and the right-side of this equation are shown in Figure 2.12 and Figure 2.13.

In Figure 2.12, the circuit reduction rule for \otimes is applied. Then, the resulting diagram is obtained after applying box-eats-box rule. In Figure 2.13, at first box-eats-box rule is applied to the first two functor boxes, then this rule is applied again. Inside the box, the circuit reduction rule for \otimes is applied. Finally, after applying the circuit reduction rule for \otimes , we get the resulting diagram which is the same as the resulting diagram of Figure 2.12.

2.13 Linear functors

Cockett and Seely introduced the notion of linear functors between linearly distributive categories [14] to express the common linear structures such as exponentials and additives. In this thesis, linear functors play a very important role because they gives the basic building

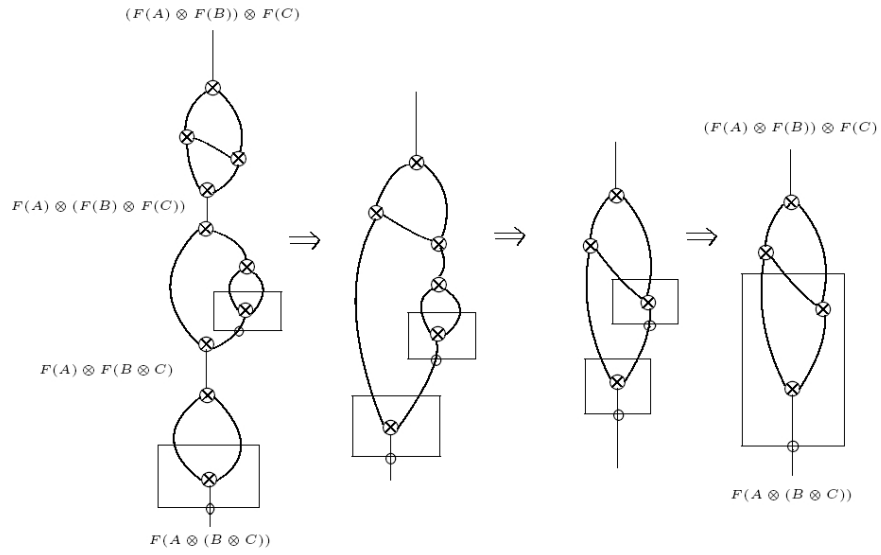

Figure 2.12: Circuit diagrams for $a_{\otimes} (1 \otimes m_{\otimes}) m_{\otimes}$

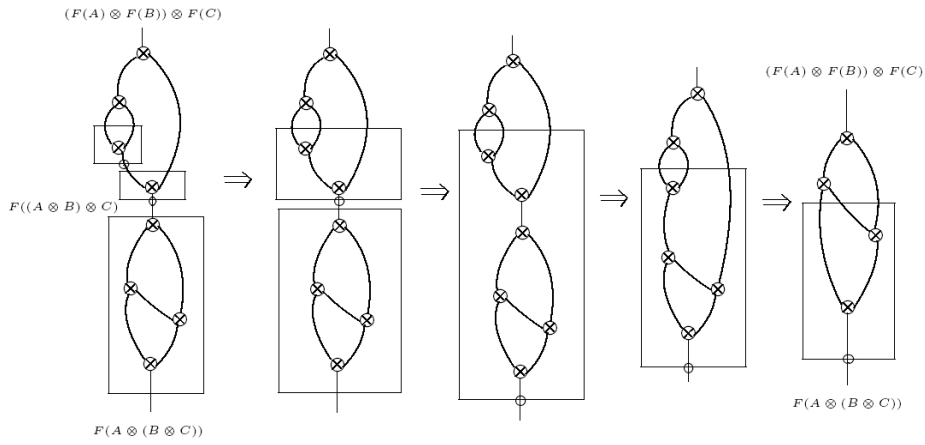

Figure 2.13: Circuit diagrams for $(m_{\otimes} \otimes 1) m_{\otimes} F(a_{\otimes})$

block for data or protocols in concurrent communication which we shall use to build further linear functors. Note that, protocols can be built on functors which are not linear.

Suppose \mathbb{X} and \mathbb{Y} are linearly distributive categories. Then a linear functor is a tuple $(F_{\otimes}, F_{\oplus}, v_{\otimes}^R, v_{\otimes}^L, v_{\oplus}^R, v_{\oplus}^L)$ where

- $F_{\otimes} : \mathbb{X} \rightarrow \mathbb{Y}$ is a monoidal functor on \otimes ;
- $F_{\oplus} : \mathbb{X} \rightarrow \mathbb{Y}$ is a comonoidal functor on \oplus ;
- The four natural transformations are as follows:

$$v_{\otimes}^R : F_{\otimes}(A \oplus B) \rightarrow F_{\oplus}(A) \oplus F_{\otimes}(B)$$

$$v_{\otimes}^L : F_{\otimes}(A \oplus B) \rightarrow F_{\otimes}(A) \oplus F_{\oplus}(B)$$

$$v_{\oplus}^R : F_{\otimes}(A) \otimes F_{\oplus}(B) \rightarrow F_{\oplus}(A \otimes B)$$

$$v_{\oplus}^L : F_{\oplus}(A) \otimes F_{\otimes}(B) \rightarrow F_{\oplus}(A \otimes B)$$

These natural transformations are called “linear strengths” satisfying several coherence conditions which are discussed in Appendix B.

Sometimes we shall denote F_{\otimes} by F and F_{\oplus} by \bar{F} to save space.

Example:

A functor $F : \mathbb{1} \rightarrow \mathbb{X}$, from the one-object-one-arrow category $\mathbb{1}$ to a linearly distributive category \mathbb{X} , preserves all the structure of a linear functor. The one-object-one-arrow category $\mathbb{1}$ is a linearly distributive category where $1 \otimes 1 := 1$, $1 \oplus 1 := 1$. A linear functor $F : \mathbb{1} \rightarrow \mathbb{X}$ determines a linear Frobenius algebra in \mathbb{X} . Setting $F_{\otimes}(1) := A_{\otimes}$ and $F_{\oplus}(1) := A_{\oplus}$ then the functor implies the presence of the following maps.

$$A_{\otimes} \otimes A_{\otimes} = F_{\otimes}(1) \otimes F_{\otimes}(1) \xrightarrow{m_{\otimes}} F_{\otimes}(1 \otimes 1) = A_{\otimes} \text{ (multiplication)}$$

$$A_{\oplus} = F_{\oplus}(1 \oplus 1) \xrightarrow{n_{\oplus}} F_{\oplus}(1) \oplus F_{\oplus}(1) = A_{\oplus} \oplus A_{\oplus} \text{ (comultiplication)}$$

$$\begin{aligned}
A_{\otimes} \otimes A_{\oplus} &= F_{\otimes}(1) \oplus F_{\oplus}(1) \xrightarrow{v_{\oplus}^R} F_{\oplus}(1 \otimes 1) = A_{\oplus} \text{ (linear Frobenius maps)} \\
A_{\oplus} \otimes A_{\otimes} &= F_{\oplus}(1) \oplus F_{\otimes}(1) \xrightarrow{v_{\oplus}^L} F_{\oplus}(1 \otimes 1) = A_{\oplus} \text{ (linear Frobenius maps)} \\
A_{\otimes} &= F_{\otimes}(1 \oplus 1) \xrightarrow{v_{\otimes}^R} F_{\oplus}(1) \oplus F_{\otimes}(1) = A_{\oplus} \oplus A_{\otimes} \text{ (linear Frobenius maps)} \\
A_{\otimes} &= F_{\otimes}(1 \oplus 1) \xrightarrow{v_{\otimes}^L} F_{\otimes}(1) \oplus F_{\oplus}(1) = A_{\otimes} \oplus A_{\oplus} \text{ (linear Frobenius maps)} \\
&\quad \top \xrightarrow{m_{\top}} F_{\otimes} \text{ (unit of multiplication)} \\
&\quad F_{\oplus} \xrightarrow{n_{\perp}} \perp \text{ (counit of comultiplication)}
\end{aligned}$$

2.14 Circuit diagrams for linear functors

Linear functors consist of monoidal and comonoidal functors. So the linear functor boxes will have both monoidal and comonoidal components. Figure 2.14 shows the linear functor boxes where component f is inside the functor boxes which has many inputs and many outputs.

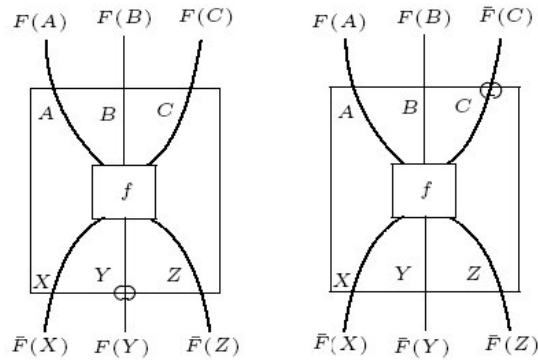

Figure 2.14: Linear functor boxes with monoidal and comonoidal components

In Figure 2.14, at the left-hand of diagram, the functor F is applied to all the input wires but at the bottom, the functor F is attached only to the middle output wire that leaves through the principal port which is denoted by a circle. The position of the principal port

is therefore important. The dual situation is shown in the right-hand of diagram of Figure 2.14 where the \bar{F} functor is on the rightmost input wire at the top that leaves through the principal port which is denoted by a circle while at the bottom of the box, \bar{F} functor is applied to all the output wires.

The four “linear strengths” can be represented by linear functor boxes which are shown in Figure 2.15. For v_{\otimes}^R and v_{\otimes}^L , component f is replaced by the link $(\oplus E)$ which has one input $A \oplus B$ and two outputs A and B ; then F functor is applied at the top of the boxes in both cases while \bar{F} is passing through the principal ports at the bottom right and bottom left of the functor boxes respectively. On the other hand, for v_{\oplus}^R and v_{\oplus}^L , component f is replaced by the link $(\otimes I)$ which has two inputs A and B and one output $A \otimes B$; then at the top of the boxes, functor \bar{F} is applied to the right and the left input wires respectively passing through the principal ports, indicated by circles while \bar{F} functor is applied at the bottom of the boxes in both cases.

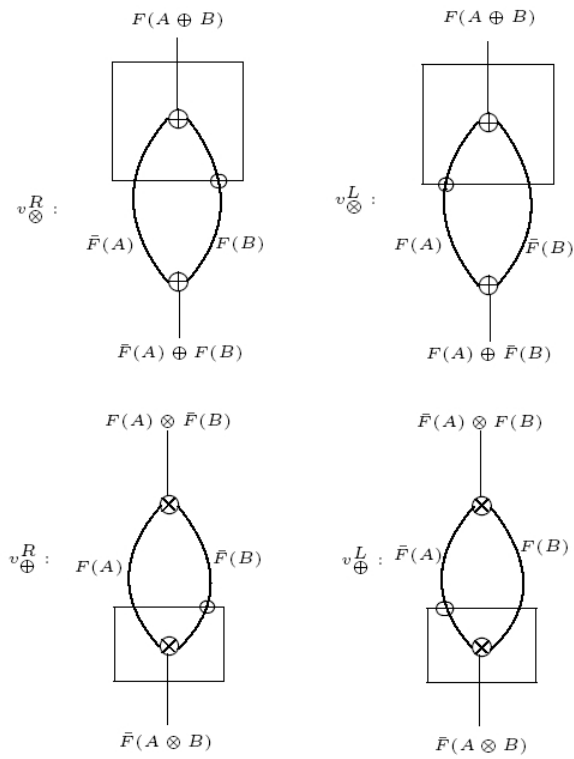

Figure 2.15: Functor boxes for linear strengths

Chapter 3

Linear Actegories and their Two Actions

This chapter describes linear actegories and provides a proof of the first main result of this thesis which is Theorem 3.3.2. Section 3.1 presents the definition of a linear actegory and Section 3.2 presents the circuit representation for linear actegories. In Section 3.3, Theorem 3.3.2 is stated and proved: it says the actions defined in a linear actegory have the structure of a parameterized linear functor. This is used as a basic building block for producing protocols.

3.1 Linear Actegories

A linear actegory [8] is a linearly distributive category with a monoidal category that acts on it both covariantly and contravariantly. Suppose $\mathbb{A} = (\mathbb{A}, *, I, a_*, l_*, r_*, c_*)$ is a symmetric monoidal category. A (symmetric) linear \mathbb{A} -actegory consists of the following data.

- A symmetric linearly distributive category \mathbb{X} .
- Two functors $\circ : \mathbb{A} \times \mathbb{X} \rightarrow \mathbb{X}$ and $\bullet : \mathbb{A}^{op} \times \mathbb{X} \rightarrow \mathbb{X}$ such that $A \circ _$ is the parameterized left adjoint of $A \bullet _$. So the adjunction can be written as $(n, e) : A \circ _ \vdash A \bullet _$ where the unit and counit are denoted by $n_{A,X} : X \rightarrow A \bullet (A \circ X)$ and $e_{A,X} : A \circ (A \bullet X) \rightarrow X$.

- The following natural isomorphisms in \mathbb{X} for all $A, B \in \mathbb{A}$ and $X, Y \in \mathbb{X}$:

$$u_{\circ} : I \circ X \rightarrow X,$$

$$u_{\bullet} : X \rightarrow I \bullet X,$$

$$a_{\circ}^* : (A * B) \circ X \rightarrow A \circ (B \circ X),$$

$$a_{\bullet}^* : A \bullet (B \bullet X) \rightarrow (A * B) \bullet X,$$

$$a_{\otimes}^{\circ} : A \circ (X \otimes Y) \rightarrow (A \circ X) \otimes Y,$$

$$a_{\oplus}^{\bullet} : (A \bullet X) \oplus Y \rightarrow A \bullet (X \oplus Y).$$

- The following natural morphisms in \mathbb{X} for all $A, B \in \mathbb{A}$ and $X, Y \in \mathbb{X}$:

$$d_{\oplus}^{\circ} : A \circ (X \oplus Y) \rightarrow (A \circ X) \oplus Y,$$

$$d_{\otimes}^{\bullet} : (A \bullet X) \otimes Y \rightarrow A \bullet (X \otimes Y),$$

$$d_{\bullet}^{\circ} : A \circ (B \bullet X) \rightarrow B \bullet (A \circ X).$$

- The following natural transformations (or isomorphisms) from the symmetries of $*$, \otimes , and \oplus :

$$a_{\circ}^{\prime} : (A * B) \circ X \rightarrow B \circ (A \circ X),$$

$$a_{\bullet}^{\prime} : B \bullet (A \bullet X) \rightarrow (A * B) \bullet X,$$

$$a_{\otimes}^{\circ} : A \circ (X \otimes Y) \rightarrow X \otimes (A \circ Y),$$

$$a_{\oplus}^{\bullet} : X \oplus (A \bullet Y) \rightarrow A \bullet (X \oplus Y),$$

$$d_{\oplus}^{\circ} : A \circ (X \oplus Y) \rightarrow X \oplus (A \circ Y),$$

$$d_{\otimes}^{\bullet} : X \otimes (A \bullet Y) \rightarrow A \bullet (X \otimes Y).$$

The above data must satisfy a large number of coherence conditions listed in Appendix A. Below are the coherence conditions which will be used in Section 3.3 for proving Proposition

3.3.1 and Theorem 3.3.2 are collected. The rest of the coherence conditions are listed in Appendix A and are obtained by applying the symmetries.

This data has several symmetries [8]. The main source of symmetry is a basic duality, obtained by reversing the arrows, swapping \otimes and \oplus , \top and \perp , \circ and \bullet . In addition, symmetries are also obtained by reversing the $*$, the \otimes , and the \oplus . All of these symmetries are preserved by the coherences of a linear actegory.

Symmetries: The following diagram links symmetry and the associativity of the action:

$$\begin{array}{ccc}
 A \circ (X \otimes Y) & \xrightarrow{a_{\otimes}^{\circ}} & (A \circ X) \otimes Y \\
 A \circ c_{\otimes} \downarrow & & \downarrow c_{\otimes} \\
 A \circ (Y \otimes X) & \xrightarrow{a_{\otimes'}^{\circ}} & Y \otimes (A \circ X)
 \end{array}$$

$$a_{\otimes}^{\circ} c_{\otimes} = (A \circ c_{\otimes}) a_{\otimes'}^{\circ} \quad (3.1)$$

Unit and associativity: The following diagrams commute for unit and associativity:

$$\begin{array}{ccc}
 (A * I) \circ X & \xrightarrow{a_{\circ}^*} & A \circ (I \circ X) \\
 r_* \circ X \downarrow & \swarrow A \circ u_{\circ} & \\
 A \circ X & &
 \end{array}$$

$$a_{\circ}^* A \circ u_{\circ} = r_* \circ X \quad (3.2)$$

$$\begin{array}{ccc}
 A \bullet X & \xrightarrow{u_{\bullet}} & I \bullet (A \bullet X) \\
 l_*^{-1} \bullet X \downarrow & \swarrow a_{\bullet}^* & \\
 (I * A) \bullet X & &
 \end{array}$$

$$u_{\bullet} a_{\bullet}^* = l_*^{-1} \bullet X \quad (3.3)$$

$$\begin{array}{ccc}
 A \circ (\top \otimes Y) & \xrightarrow{a_{\otimes'}^{\circ}} & \top \otimes (A \circ Y) \\
 A \circ l_{\otimes} \downarrow & \swarrow l_{\otimes} & \\
 A \circ Y & &
 \end{array}$$

$$a_{\otimes'}^{\circ} l_{\otimes} = A \circ l_{\otimes} \quad (3.4)$$

Unit and distributivity: The following diagrams link unit and distributivity:

$$\begin{array}{ccc}
 X \otimes Y & \xrightarrow{u_{\bullet} \otimes Y} & (I \bullet X) \otimes Y \\
 u_{\bullet} \downarrow & \swarrow d_{\otimes}^{\bullet} & \\
 I \bullet (X \otimes Y) & &
 \end{array}$$

$$(u_{\bullet} \otimes Y) d_{\otimes}^{\bullet} = u_{\bullet} \quad (3.5)$$

$$\begin{array}{ccc}
 I \circ (X \otimes Y) & \xrightarrow{a_{\otimes}^{\circ}} & (I \circ X) \otimes Y \\
 u_{\circ} \downarrow & \swarrow u_{\circ} \otimes Y & \\
 X \otimes Y & &
 \end{array}$$

$$a_{\otimes}^{\circ} (u_{\circ} \otimes Y) = u_{\circ} \quad (3.6)$$

Associativity: The following diagrams commute for associativity:

$$\begin{array}{ccc}
 A \bullet (B \bullet (C \bullet X)) & \xrightarrow{A \bullet a_{\bullet}^*} & A \bullet ((B * C) \bullet X) \\
 a_{\bullet}^* \downarrow & & \downarrow a_{\bullet}^* \\
 (A * B) \bullet (C \bullet X) & \xrightarrow{a_{\bullet}^*} & ((A * B) * C) \bullet X \\
 & & \downarrow a_{\bullet}^{-1} \bullet X \\
 & & (A * (B * C)) \bullet X
 \end{array}$$

$$(A \bullet a_{\bullet}^*) a_{\bullet}^* (a_{\bullet}^{-1} \bullet X) = a_{\bullet}^* a_{\bullet}^* \quad (3.7)$$

$$\begin{array}{ccc}
 (A * B) \circ (Y \otimes X) & \xrightarrow{a_{\circ}^*} & A \circ (B \circ (Y \otimes X)) \\
 a_{\otimes'}^{\circ} \downarrow & & \downarrow A \circ a_{\otimes'}^{\circ} \\
 Y \otimes ((A * B) \circ X) & \xrightarrow{Y \otimes a_{\circ}^*} & Y \otimes (A \circ (B \circ X)) \\
 & & \downarrow a_{\otimes'}^{\circ} \\
 & & A \circ (Y \otimes (B \circ X))
 \end{array}$$

$$a_{\circ}^* (A \circ a_{\otimes'}^{\circ}) a_{\otimes'}^{\circ} = a_{\otimes'}^{\circ} (Y \otimes a_{\circ}^*) \quad (3.8)$$

Distributivity and associativity: The following diagrams commute for distributivity and associativity:

$$\begin{array}{ccc}
Y \otimes (A \bullet (B \bullet X)) & \xrightarrow{d_{\otimes'}^{\bullet}} & A \bullet (Y \otimes (B \bullet X)) \\
\downarrow Y \otimes a_{\bullet}^* & & \downarrow A \bullet d_{\otimes'}^{\bullet} \\
Y \otimes ((A * B) \bullet X) & \xrightarrow{d_{\otimes'}^{\bullet}} & (A * B) \bullet (Y \otimes X) \\
& & \downarrow a_{\bullet}^* \\
& & A \bullet (B \bullet (Y \otimes X))
\end{array}$$

$$d_{\otimes'}^{\bullet} (A \bullet d_{\otimes'}^{\bullet}) a_{\bullet}^* = (Y \otimes a_{\bullet}^*) d_{\otimes'}^{\bullet} \quad (3.9)$$

$$\begin{array}{ccc}
((A \bullet X) \otimes Y) \otimes Z & \xrightarrow{d_{\otimes}^{\bullet} \otimes Z} & (A \bullet (X \otimes Y)) \otimes Z \\
\downarrow a_{\otimes} & & \downarrow d_{\otimes}^{\bullet} \\
(A \bullet X) \otimes (Y \otimes Z) & \xrightarrow{d_{\otimes}^{\bullet}} & A \bullet ((X \otimes Y) \otimes Z) \\
& & \downarrow A \bullet a_{\otimes} \\
& & A \bullet (X \otimes (Y \otimes Z))
\end{array}$$

$$\begin{array}{ccc}
Z \otimes (X \otimes (A \bullet Y)) & \xrightarrow{Z \otimes d_{\otimes'}^{\bullet}} & Z \otimes (A \bullet (X \otimes Y)) \\
\downarrow a_{\otimes}^{-1} & & \downarrow d_{\otimes'}^{\bullet} \\
(Z \otimes X) \otimes (A \bullet Y) & \xrightarrow{d_{\otimes'}^{\bullet}} & A \bullet (Z \otimes (X \otimes Y)) \\
& & \downarrow A \bullet a_{\otimes}^{-1} \\
& & A \bullet ((Z \otimes X) \otimes Y)
\end{array}$$

$$\begin{array}{ccc}
(X \otimes (A \bullet Y)) \otimes Z & \xrightarrow{d_{\otimes'}^{\bullet} \otimes Z} & (A \bullet (X \otimes Y)) \otimes Z \\
\downarrow a_{\otimes} & & \downarrow d_{\otimes}^{\bullet} \\
X \otimes ((A \bullet Y) \otimes Z) & \xrightarrow{X \otimes d_{\otimes}^{\bullet}} & A \bullet ((X \otimes Y) \otimes Z) \\
& & \downarrow A \bullet a_{\otimes} \\
& & A \bullet (X \otimes (Y \otimes Z)) \\
X \otimes (A \bullet (Y \otimes Z)) & \xrightarrow{d_{\otimes'}^{\bullet}} & A \bullet (X \otimes (Y \otimes Z))
\end{array}$$

$$(d_{\otimes}^{\bullet} \otimes Z) d_{\otimes}^{\bullet} (A \bullet a_{\otimes}) = a_{\otimes} d_{\otimes}^{\bullet} \quad (3.10)$$

$$(Z \otimes d_{\otimes'}^{\bullet}) d_{\otimes'}^{\bullet} (A \bullet a_{\otimes}^{-1}) = a_{\otimes}^{-1} d_{\otimes'}^{\bullet}, \quad (3.11)$$

$$(d_{\otimes'}^{\bullet} \otimes Z) d_{\otimes}^{\bullet} (A \bullet a_{\otimes}) = a_{\otimes} (X \otimes d_{\otimes}^{\bullet}) d_{\otimes'}^{\bullet}, \quad (3.12)$$

$$\begin{array}{ccc}
(A \bullet (X \otimes Y)) \otimes (B \bullet Z) & \xrightarrow{d_{\otimes}^{\bullet}} & A \bullet ((X \otimes Y) \otimes (B \bullet Z)) \\
d_{\otimes'}^{\bullet} \downarrow & & \downarrow A \bullet d_{\otimes'}^{\bullet} \\
B \bullet ((A \bullet (X \otimes Y)) \otimes Z) & & A \bullet (B \bullet ((X \otimes Y) \otimes Z)) \\
B \bullet d_{\otimes}^{\bullet} \downarrow & & \downarrow a_{\bullet}^* \\
B \bullet (A \bullet ((X \otimes Y) \otimes Z)) & \xrightarrow{a_{\bullet}^{*'}} & (A * B) \bullet ((X \otimes Y) \otimes Z)
\end{array}$$

$$d_{\otimes}^{\bullet} (A \bullet d_{\otimes'}^{\bullet}) a_{\bullet}^* = d_{\otimes'}^{\bullet} (B \bullet d_{\otimes}^{\bullet}) a_{\bullet}^{*'} \quad (3.13)$$

Unit and counit: The following diagrams link unit and counit:

$$\begin{array}{ccc}
I \circ X & \xrightarrow{I \circ u_{\bullet}} & I \circ (I \bullet X) \\
u_{\circ} \downarrow & \swarrow e_{I,X} & \\
X & &
\end{array}$$

$$(I \circ u_{\bullet}) e_{I,X} = u_{\circ} \quad (3.14)$$

$$\begin{array}{ccc}
A \circ ((A \bullet X) \otimes Y) & \xrightarrow{A \circ d_{\otimes}^{\bullet}} & A \circ (A \bullet (X \otimes Y)) \\
a_{\otimes}^{\circ} \downarrow & & \downarrow e_{A,X \otimes Y} \\
(A \circ (A \bullet X)) \otimes Y & \xrightarrow{e_{A,X \otimes Y}} & X \otimes Y
\end{array}$$

$$(A \circ d_{\otimes}^{\bullet}) e_{A,X \otimes Y} = a_{\otimes}^{\circ} (e_{A,X} \otimes Y) \quad (3.15)$$

In linear actegories, originally the $*$ is just a symmetric tensor (\otimes) but here it is a cartesian product (\times).

3.2 Circuit diagrams for linear actegories

In this section we describe the circuit rules for linear actegories. These circuit rules are discussed in [8]. Figures 3.1 - 3.6 show the circuit introduction, elimination, reduction and expansion rules for \circ , \bullet , and $*$. In Figures 3.7, 3.8 and 3.9, copy rule, box-elimination rule and box-eats-box rule are shown. Copy rule takes one input and produces two copies of that

input. Box-eats-box rule combines two functor boxes where we pushed the top box inside the bottom box and box-elimination rule eliminates functor box by connecting wires. Figure 3.10 shows the circuit diagrams for a_{\circ}^* , a_{\oplus}^{\bullet} , a_{\bullet}^* , and a_{\otimes}° and Figure 3.11 shows the circuit representation of d_{\oplus}° , d_{\otimes}^{\bullet} , and d_{\bullet}° .



Figure 3.1: Circuit introduction and elimination rules for \circ

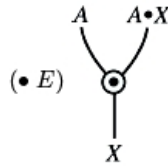

Figure 3.2: Circuit elimination rule for \bullet

We can prove equalities in linear categories using the circuit rules of linear categories and linearly distributive categories (discussed in Section 2.10). Consider the coherence condition $(A \circ d_{\otimes}^{\bullet}) d_{\bullet}^{\circ} (B \bullet a_{\otimes}^{\circ}) = a_{\otimes}^{\circ} d_{\bullet}^{\circ}$. In Figure 3.12 and Figure 3.13 the left-hand side and the right-hand side of this coherence condition are shown. In Figure 3.12 we apply the circuit

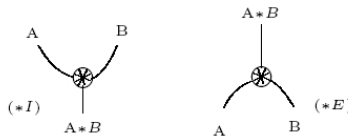

Figure 3.3: Circuit introduction and elimination rules for $*$

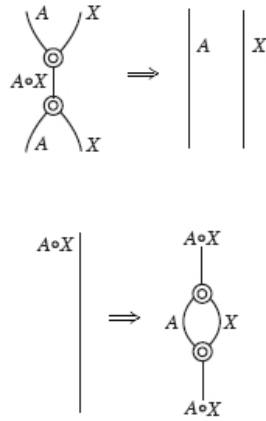

Figure 3.4: Circuit reduction and expansion rule for \circ

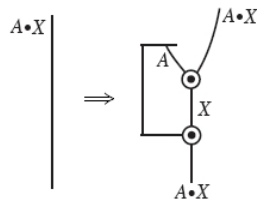

Figure 3.5: Circuit expansion rule for \bullet

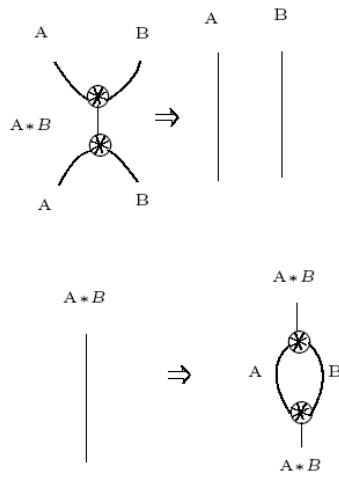

Figure 3.6: Circuit reduction and expansion rules for $*$

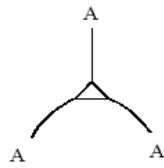

Figure 3.7: Copy rule

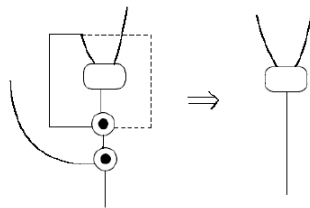

Figure 3.8: Box-elimination rule

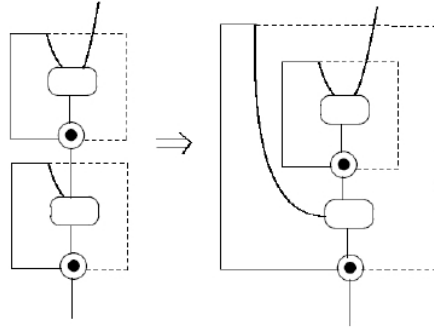

Figure 3.9: Box-eats-box rule

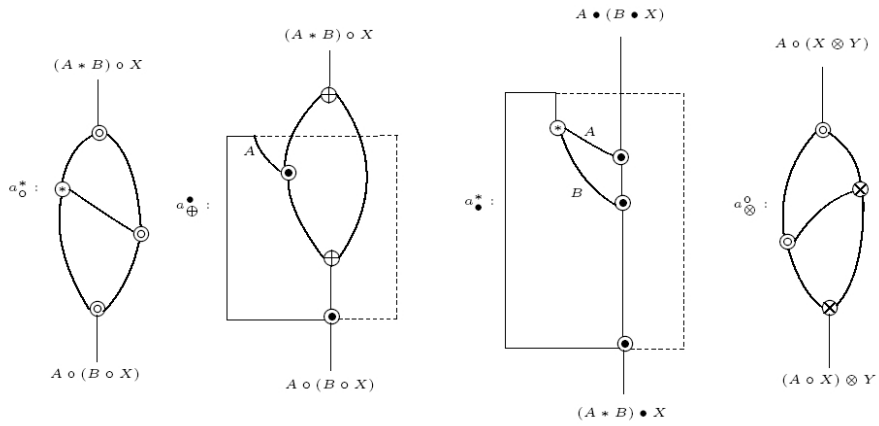

Figure 3.10: Circuit diagrams of a_0^* , a_{\oplus}^{\bullet} , a_{\bullet}^* and a_{\otimes}°

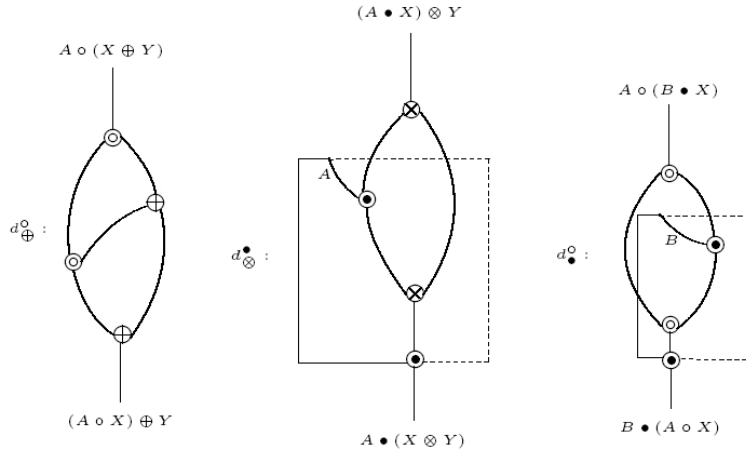

Figure 3.11: Circuit diagrams of d_{\oplus}° , d_{\otimes}^{\bullet} , and d_{\bullet}° .

reduction rule for \otimes , and then we get the resulting diagram. In Figure 3.13 the circuit reduction rule for \circ is applied first, and then the box-eats-box rule. After that, inside the box, we apply the box-elimination rule, and then the circuit reduction rule for \otimes . Finally, we get the resulting diagram which is equivalent to the resulting diagram of Figure 3.12.

3.3 Actions and linear functors

In this chapter, our main goal is to show that the two actions of linear categories provide a parameterized linear functor. To prove this we first have to show that $A \bullet _$ is a monoidal functor and dually, $A \circ _$ is a comonoidal functor. Then we have to show that there exist linear strengths between the two functors, $A \bullet _$ and $A \circ _$, satisfying the coherence conditions which are discussed in the definition of linear functor (Section 2.13).

Proposition 3.3.1. *$A \bullet _$ is a monoidal functor (dually, $A \circ _$ is a comonoidal functor).*

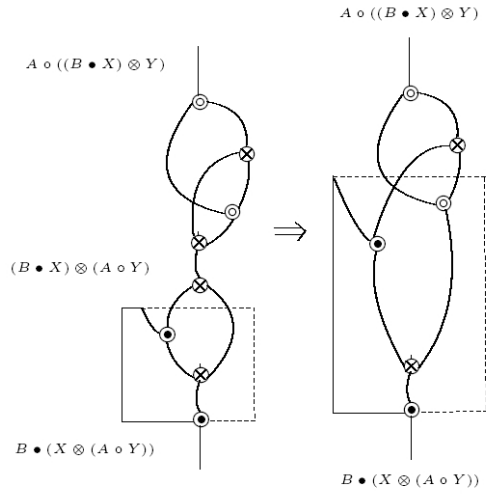

Figure 3.12: Circuit diagram for $(A \circ d_{\otimes}^{\bullet}) d_{\bullet}^{\circ} (B \bullet a_{\otimes}^{\circ})$

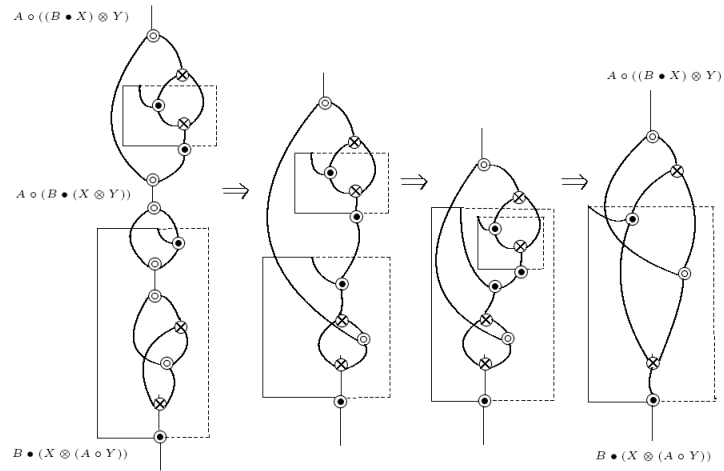

Figure 3.13: Circuit diagram for $a_{\otimes}^{\circ}, d_{\otimes}^{\bullet}$

Proof. For a functor to be monoidal, there are two natural transformations:

$$m_{\otimes} : (A \bullet X) \otimes (A \bullet Y) \rightarrow A \bullet (X \otimes Y)$$

$$m_{\top} : \top \rightarrow (A \bullet \top)$$

These natural transformations must satisfy two equations.

$$l_{\otimes} = (m_{\top} \otimes 1) m_{\otimes} (A \bullet l_{\otimes})$$

$$a_{\otimes} (1 \otimes m_{\otimes}) m_{\otimes} = (m_{\otimes} \otimes 1) m_{\otimes} (A \bullet a_{\otimes})$$

To prove these two equations hold, we have to define m_{\otimes} and m_{\top} . Figure 3.14 and Figure 3.15 show the defining diagrams of m_{\otimes} and m_{\top} respectively.

$$\begin{array}{ccc}
 (A \bullet X) \otimes (A \bullet Y) & \xrightarrow{m_{\otimes}} & A \bullet (X \otimes Y) \\
 d_{\otimes}^{\bullet} \downarrow & & \Delta \bullet 1 \uparrow \\
 A \bullet (X \otimes (A \bullet Y)) & \xrightarrow{A \bullet d_{\otimes}^{\bullet}} A \bullet (A \bullet (X \otimes Y)) \xrightarrow{a_{\bullet}^*} & (A * A) \bullet (X \otimes Y)
 \end{array}$$

Figure 3.14: Defining diagram of m_{\otimes}

$$\begin{array}{ccc}
 \top & \xrightarrow{m_{\top}} & A \bullet \top \\
 u_{\bullet} \downarrow & \nearrow ! \bullet \top & \\
 1 \bullet \top & &
 \end{array}$$

Figure 3.15: Defining diagram of m_{\top}

Validity of the first equation, $l_{\otimes} = (m_{\top} \otimes 1) m_{\otimes} (A \bullet l_{\otimes})$, is shown in Figure 3.16 where each of the numbered cells commute for the following reasons: (1) uses equation (3.5), (2) uses the naturality of d_{\otimes}^{\bullet} , (3) and (4) use equation (3.13), (5) commutes because of the naturality of d_{\otimes}^{\bullet} , (6) uses equation (3.3), (7) commutes by the naturality of a_{\bullet}^* , (8) commutes by the combination of Δ with $(! * 1)$, (9) commutes because of bullet(\bullet) functor.

Validity of the second equation, $a_{\otimes} (1 \otimes m_{\otimes}) m_{\otimes} = (m_{\otimes} \otimes 1) m_{\otimes} (A \bullet a_{\otimes})$, is shown in Figure 3.17 where (1) commutes because of equation (3.10), (2), (3), (4), (7) and (14) commute by the naturality of d_{\otimes}^{\bullet} , (8) commutes by equation (3.12), (5), (9) and (15) commute by the naturality of d_{\otimes}^{\bullet} , (6), (13) and (16) commute because of the naturality of a_{\bullet}^* , (11) and (12) use bullet(\bullet) functor, (17) uses associativity of Δ . Validity of diagram (10) is shown in Figure 3.18. In Figure 3.18, (1) uses the naturality of d_{\otimes}^{\bullet} , (2) commutes by equation (3.11), (3), (5) and (8) use the naturality of a_{\bullet}^* , (4) commutes by equation (3.9), (6) commutes by equation (3.7), (7) and (9) use bullet(\bullet) functor.

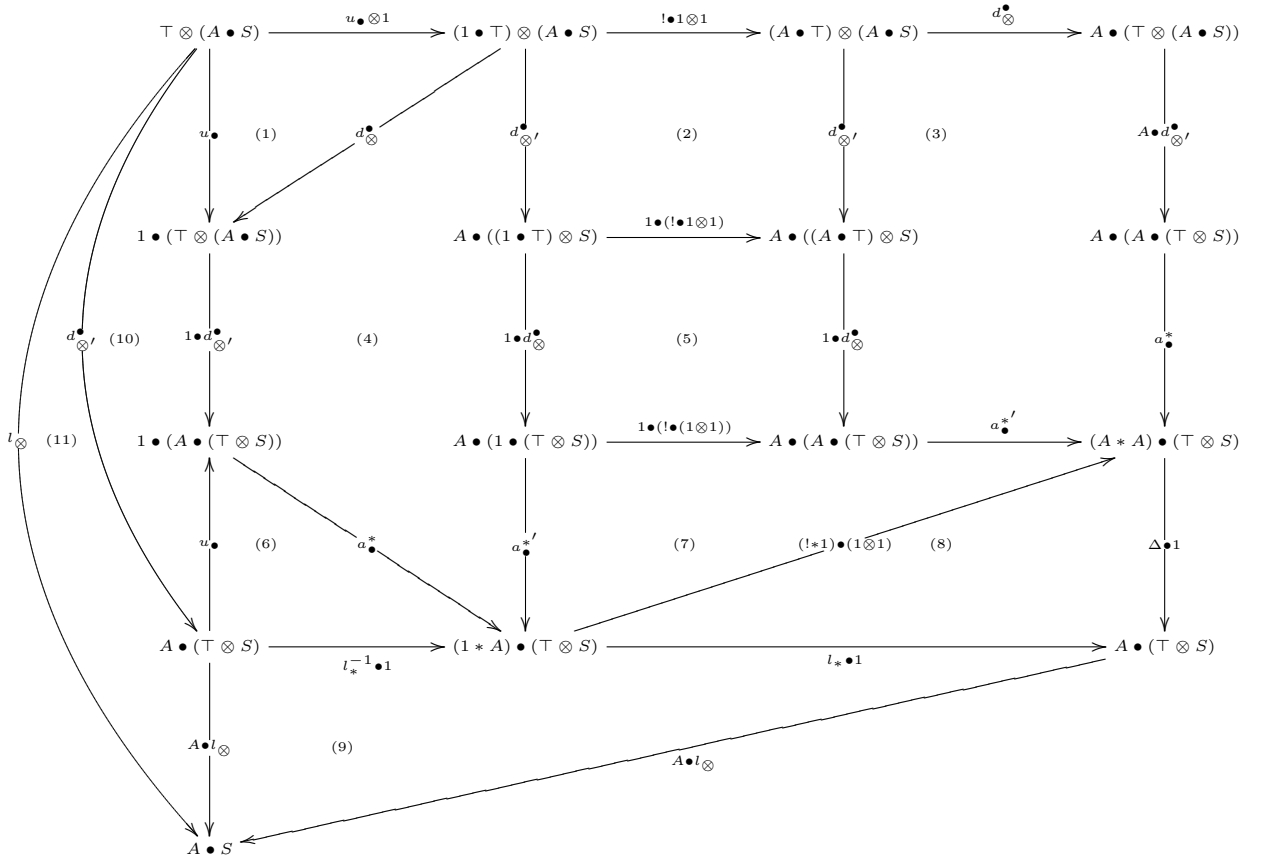

Figure 3.16: Validity of $l_{\otimes} = (m_{\top} \otimes 1) m_{\otimes} (A \bullet l_{\otimes})$

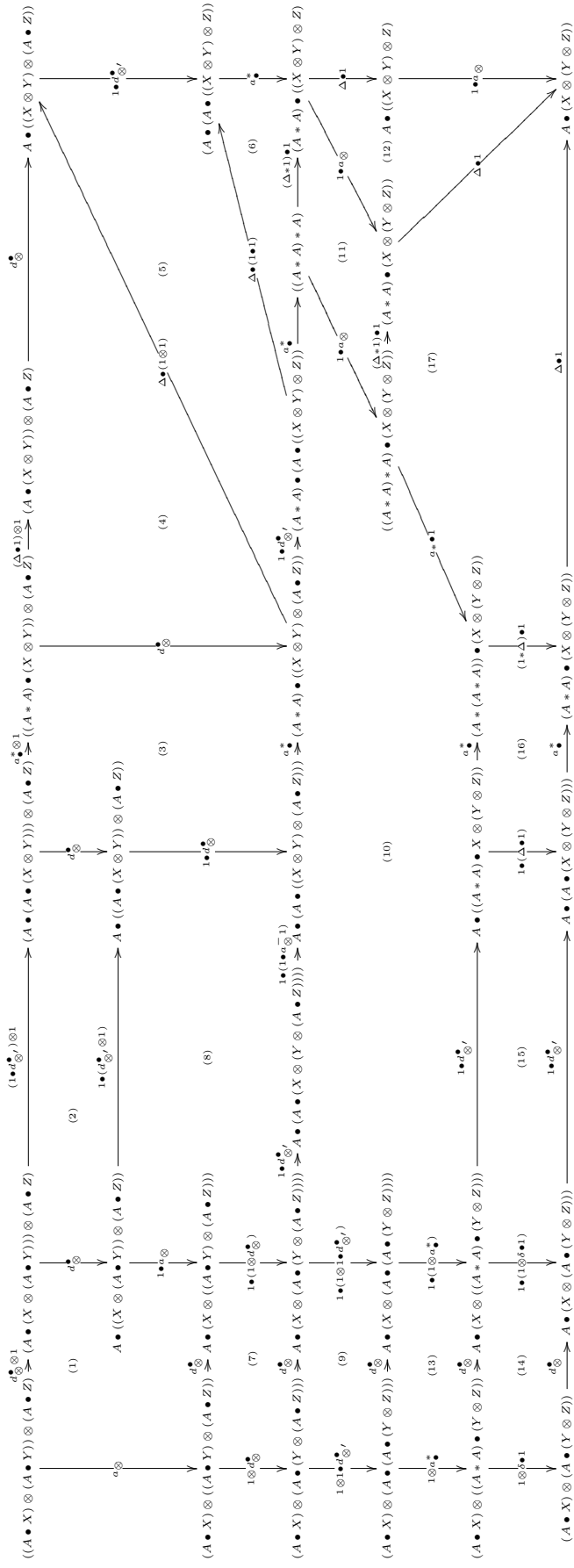

Figure 3.17: Validity of $a_{\otimes} (1 \otimes m_{\otimes}) m_{\otimes} = (m_{\otimes} \otimes 1) m_{\otimes} (A \bullet a_{\otimes})$

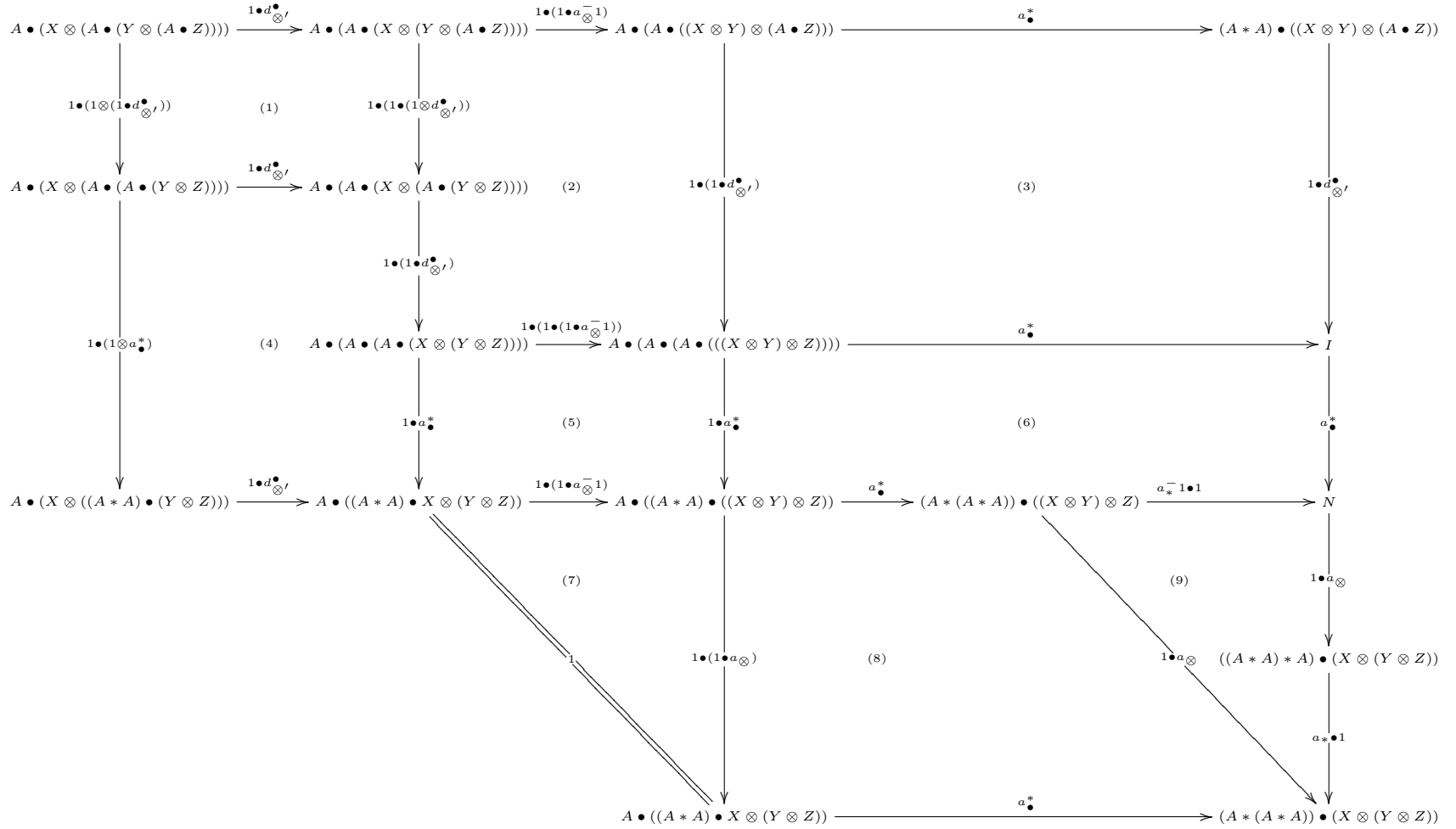

Figure 3.18: Validity of diagram (10) from Figure 3.17

In this way, we have shown $A \bullet _$ is a monoidal functor. Dually, $A \circ _$ is a comonoidal functor. \square

Theorem 3.3.2. $A \bullet _$ and $A \circ _$ have the structure of a parameterized linear functor.

Proof. We already showed in proposition 3.3.1 that $A \bullet _$ is a monoidal functor (and $A \circ _$ is a comonoidal functor). It remains to show that the linear strengths between these two functors fulfill the coherence conditions.

For a linear functor, the four natural transformations we seek, called “linear strengths”, are:

$$v_{\otimes}^R : A \bullet (X \oplus Y) \rightarrow (A \circ X) \oplus (A \bullet Y)$$

$$v_{\otimes}^L : A \bullet (X \oplus Y) \rightarrow (A \bullet X) \oplus (A \circ Y)$$

$$v_{\oplus}^R : (A \bullet X) \otimes (A \circ Y) \rightarrow A \circ (X \otimes Y)$$

$$v_{\oplus}^L : (A \circ X) \otimes (A \bullet Y) \rightarrow A \circ (X \otimes Y)$$

The defining diagrams for v_{\oplus}^R and v_{\otimes}^R are shown in Figure 3.19 and Figure 3.20. Similarly, we can define the others two linear strengths, v_{\oplus}^L and v_{\otimes}^L by using symmetry.

$$\begin{array}{ccc}
(A \bullet X) \otimes (A \circ Y) & \xrightarrow{v_{\oplus}^R} & A \circ (X \otimes Y) \\
\downarrow a_{\otimes'}^{-1} & & \uparrow A_{oe} \\
A \circ ((A \bullet X) \otimes Y) & & \\
\downarrow A_{od\bullet} & & \\
A \circ (A \bullet (X \otimes Y)) & \xrightarrow{\Delta_{\circ 1}} (A * A) \circ (A \bullet (X \otimes Y)) \xrightarrow{a_{\circ}^*} A \circ (A \circ (A \bullet (X \otimes Y))) &
\end{array}$$

Figure 3.19: Defining diagram for v_{\oplus}^R

$$\begin{array}{ccc}
A \bullet (X \oplus Y) & \xrightarrow{v_{\otimes}^R} & (A \circ X) \oplus (A \bullet Y) \\
\downarrow n & & \uparrow a_{\oplus}^{\bullet -1} \\
A \bullet (A \circ (A \bullet (X \oplus Y))) & & \\
\downarrow A \bullet d_{\bullet}^{\circ} & & \\
A \bullet (A \bullet (A \circ (X \oplus Y))) & & \\
\downarrow a_{\bullet}^* & & \\
(A * A) \bullet (A \circ (X \oplus Y)) \xrightarrow{\Delta \bullet 1} A \bullet (A \circ (X \oplus Y)) \xrightarrow{A \bullet d_{\oplus}^{\circ}} A \bullet ((A \circ X) \oplus Y) & &
\end{array}$$

Figure 3.20: Defining diagram for v_{\otimes}^R

From the definition of linear functor, we know that linear strengths satisfy several coherence conditions. In order to prove this theorem, we will check three coherence conditions. The first one is $l_{\otimes}^{-1} (m_{\top} \otimes 1) v_{\oplus}^R = A \circ l_{\otimes}^{-1}$ which creates a link between l_{\otimes}^{-1} , m_{\top} and v_{\oplus}^R . All the other forms of this coherence condition are obtained by symmetries. The second coherence condition is $(m_{\otimes} \otimes 1) v_{\oplus}^R (A \circ a_{\otimes}) = a_{\otimes} (1 \otimes v_{\oplus}^R) v_{\oplus}^R$ which creates a link between m_{\otimes} , v_{\oplus}^R and a_{\otimes} : the other forms of this coherence condition are generated by symmetries. The third coherence condition is $a_{\otimes} (1 \otimes v_{\oplus}^L) v_{\oplus}^R = (v_{\oplus}^R \otimes 1) v_{\oplus}^L (A \circ a_{\otimes})$ which establishes a link between a_{\otimes} , v_{\oplus}^L and v_{\oplus}^R : the symmetries generate all the other forms of this coherence condition.

Now we will prove that the first coherence condition, $l_{\otimes}^{-1} (m_{\top} \otimes 1) v_{\oplus}^R = A \circ l_{\otimes}^{-1}$ holds.

$$\begin{array}{ccc}
 \top \otimes (A \circ S) & \xrightarrow{m_{\top} \otimes 1} & (A \bullet \top) \otimes (A \circ S) \xrightarrow{v_{\oplus}^R} A \circ (\top \otimes S) \\
 \uparrow l_{\otimes}^{-1} & & \nearrow A \circ l_{\otimes}^{-1} \\
 A \circ S & &
 \end{array}$$

To verify $l_{\otimes}^{-1} (m_{\top} \otimes 1) v_{\oplus}^R = A \circ l_{\otimes}^{-1}$, we have to use the defining diagram of m_{\top} and v_{\oplus}^R . Figure 3.21 shows the validity of this coherence condition. In this figure, (1), (2) and (8) commute by tensor (\otimes) functor, (4) and (12) commute because of the naturality of $a_{\otimes'}^{\circ^{-1}}$, (5) uses equation (3.8), (6) commutes by the naturality of a_{\circ}^* , (7) uses the naturality of a_{\otimes}° , (9) commutes because of the dinaturality of e (See Section 2.6), (10) commutes by the functoriality of circle (\circ), (13) uses equation (3.4) and (14) uses equation (3.14). Validity of (3) and (11) are shown in Figure 3.22 and Figure 3.23 respectively.

In Figure 3.22, (1) and (4) commute by the tensor (\otimes) functor, (2), (7) and (8) commute by the naturality of $a_{\otimes'}^{\circ^{-1}}$, (3) commutes because of circle (\circ) functor, (5) uses equation (3.8), (6) commutes by the naturality of a_{\circ}^* , (9) commutes because of the naturality of a_{\otimes}° and (10) commutes by equation (3.15).

In Figure 3.23, (1) commutes by the combination of Δ with (1*!), (2) uses equation (3.2), (3) uses equation (3.6), (4) commutes by the naturality of a_{\circ}^* , (5) commutes because of the naturality of a_{\otimes}° . So we proved the coherence condition, $l_{\otimes}^{-1} (m_{\top} \otimes 1) v_{\oplus}^R = A \circ l_{\otimes}^{-1}$.

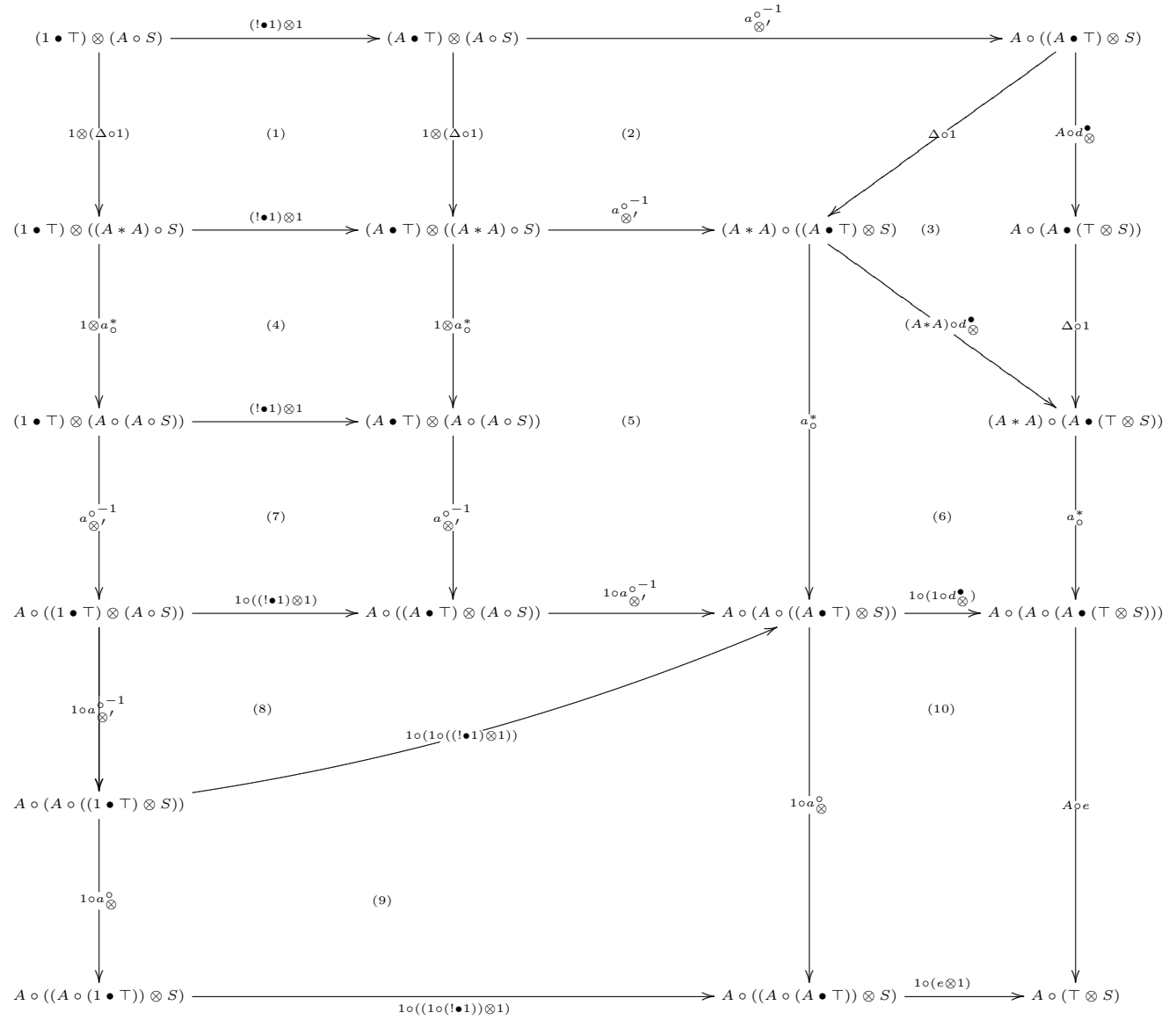

Figure 3.22: Validity of diagram (3) from Figure 3.21

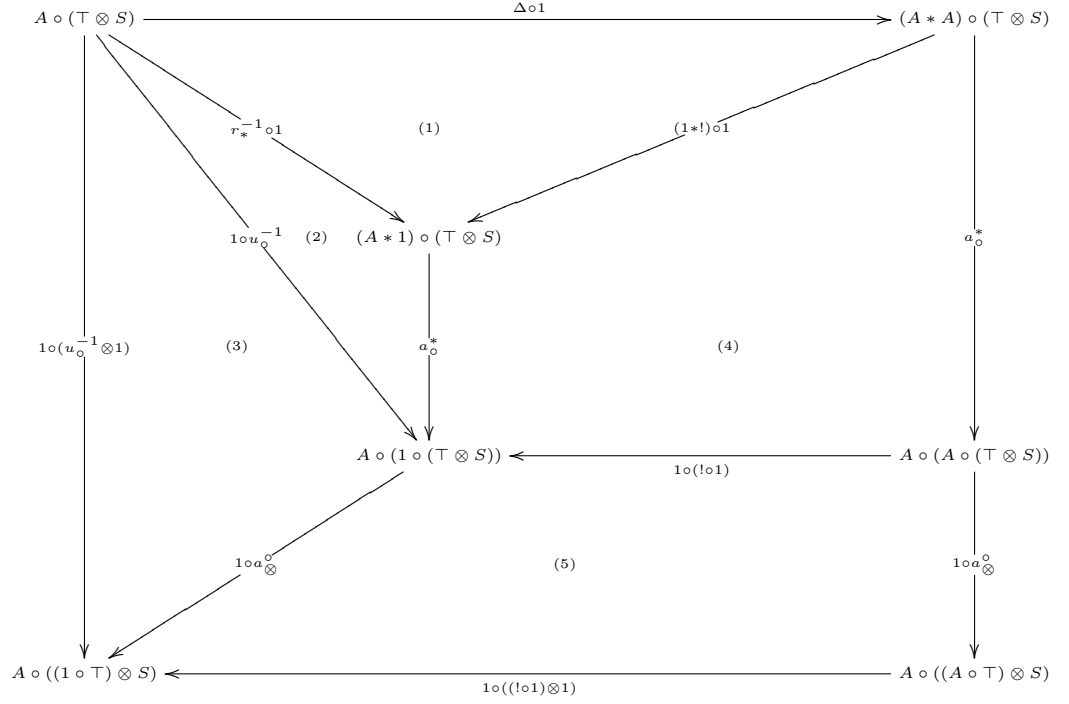

Figure 3.23: Validity of diagram (11) from Figure 3.21

Now we have to show that the second coherence condition, $(m_{\otimes} \otimes 1) v_{\oplus}^R (A \circ a_{\otimes}) = a_{\otimes} (1 \otimes v_{\oplus}^R) v_{\oplus}^R$ holds.

$$\begin{array}{ccc}
 ((A \bullet X) \otimes (A \bullet Y)) \otimes (A \circ Z) & \xrightarrow{a_{\otimes}} & (A \bullet X) \otimes ((A \bullet Y) \otimes (A \circ Z)) \\
 \downarrow m_{\otimes} \otimes 1 & & \downarrow 1 \otimes v_{\oplus}^R \\
 (A \bullet (X \otimes Y)) \otimes (A \circ Z) & & (A \bullet X) \otimes (A \circ (Y \otimes Z)) \\
 \downarrow v_{\oplus}^R & & \downarrow v_{\oplus}^R \\
 A \circ ((X \otimes Y) \otimes Z) & \xrightarrow{A \circ a_{\otimes}} & A \circ (X \otimes (Y \otimes Z))
 \end{array}$$

If we use the defining diagram of m_{\otimes} and v_{\oplus}^R then the above coherence requirement becomes the commutative diagram of Figure 3.24. But this diagram is unmanageable to prove using categorical commuting diagrams. In order to make the proof manageable we shall resort to circuit diagram proofs.

$$\begin{array}{c}
((A \bullet X) \otimes (A \bullet Y)) \otimes (A \circ Z) \xrightarrow{d_{\otimes}^{\bullet} \otimes 1} (A \bullet (X \otimes (A \bullet Y))) \otimes (A \circ Z) \xrightarrow{(A \bullet d_{\otimes}')^{\bullet} \otimes 1} (A \bullet (A \bullet (X \otimes Y))) \otimes (A \circ Z) \xrightarrow{a_{\otimes}^* \otimes 1} ((A * A) \bullet (X \otimes Y)) \otimes (A \circ Z) \xrightarrow{(\Delta \bullet 1) \otimes 1} (A \bullet (X \otimes Y)) \otimes (A \circ Z) \\
\downarrow a_{\otimes} \\
(A \bullet X) \otimes ((A \bullet Y) \otimes (A \circ Z)) \\
\downarrow 1 \otimes a_{\otimes}'^{-1} \\
(A \bullet X) \otimes (A \circ ((A \bullet Y) \otimes Z)) \\
\downarrow 1 \otimes (A \circ d_{\otimes}^{\bullet}) \\
(A \bullet X) \otimes (A \circ (A \bullet (Y \otimes Z))) \\
\downarrow 1 \otimes (\Delta \circ 1) \\
(A \bullet X) \otimes ((A * A) \circ (A \bullet (Y \otimes Z))) \\
\downarrow 1 \otimes a_{\otimes}^* \\
(A \bullet X) \otimes (A \circ (A \circ (A \bullet (Y \otimes Z)))) \\
\downarrow 1 \otimes (A \circ e) \\
(A \bullet X) \otimes (A \circ (Y \otimes Z)) \xrightarrow{a_{\otimes}'^{-1}} A \circ ((A \bullet X) \otimes (Y \otimes Z)) \xrightarrow{A \circ d_{\otimes}^{\bullet}} A \circ (A \bullet (X \otimes (Y \otimes Z))) \xrightarrow{\Delta \circ 1} (A * A) \circ (A \bullet (X \otimes (Y \otimes Z))) \xrightarrow{a_{\otimes}^*} A \circ (A \circ (A \bullet (X \otimes (Y \otimes Z)))) \xrightarrow{A \circ e} A \circ (X \otimes (Y \otimes Z)) \\
\downarrow a_{\otimes}'^{-1} \\
A \circ ((A \bullet (X \otimes Y)) \otimes Z) \\
\downarrow A \circ d_{\otimes}^{\bullet} \\
A \circ (A \bullet ((X \otimes Y) \otimes Z)) \\
\downarrow \Delta \circ 1 \\
(A * A) \circ (A \bullet ((X \otimes Y) \otimes Z)) \\
\downarrow a_{\otimes}^* \\
A \circ (A \circ (A \bullet ((X \otimes Y) \otimes Z))) \\
\downarrow A \circ e \\
A \circ ((X \otimes Y) \otimes Z) \\
\downarrow A \circ a_{\otimes} \\
A \circ (X \otimes (Y \otimes Z))
\end{array}$$

Figure 3.24: Validity of $(m_{\otimes} \otimes 1) v_{\oplus}^R (A \circ a_{\otimes}) = a_{\otimes} (1 \otimes v_{\oplus}^R) v_{\oplus}^R$

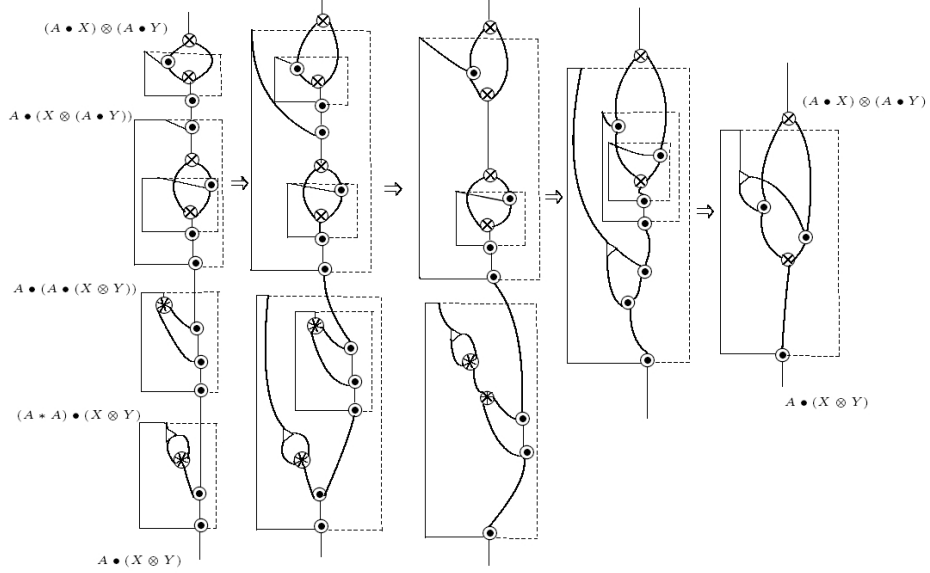

Figure 3.25: Circuit Diagram of m_\otimes for \bullet

To prove the coherence condition, $(m_\otimes \otimes 1) v_\oplus^R (A \circ a_\otimes) = a_\otimes (1 \otimes v_\oplus^R) v_\oplus^R$ using circuit diagrams, first we need circuit diagrams for m_\otimes and v_\oplus^R : these are shown in Figure 3.25 and Figure 3.26 respectively.

In Figure 3.25, the input for m_\otimes is $(A \bullet X) \otimes (A \bullet Y)$ and the output is $A \bullet (X \otimes Y)$. We first apply box-eats-box rule for the first two functor boxes and also for the last two functor boxes. Then we apply box-elimination rule inside of these. After that, we use circuit reduction rule for $*$ and box-eats-box rule. Finally, after applying box-elimination rule, we get the resulting diagram.

In Figure 3.26, the input for v_\oplus^R is $(A \bullet X) \otimes (A \circ Y)$ and the output is $A \circ (X \otimes Y)$. At the first step, we apply circuit reduction rule for \circ , then we apply circuit reduction rules for \otimes and \circ . Finally, we apply box-elimination rule.

Now, we can draw the circuit diagram for $(m_\otimes \otimes 1) v_\oplus^R (A \circ a_\otimes) = a_\otimes (1 \otimes v_\oplus^R) v_\oplus^R$. Figure 3.27 shows the circuit diagram for $(m_\otimes \otimes 1) v_\oplus^R (A \circ a_\otimes)$ (left side of the coherence condition). Here we use the circuit diagram for m_\otimes and v_\oplus^R . First we apply the circuit reduction rules

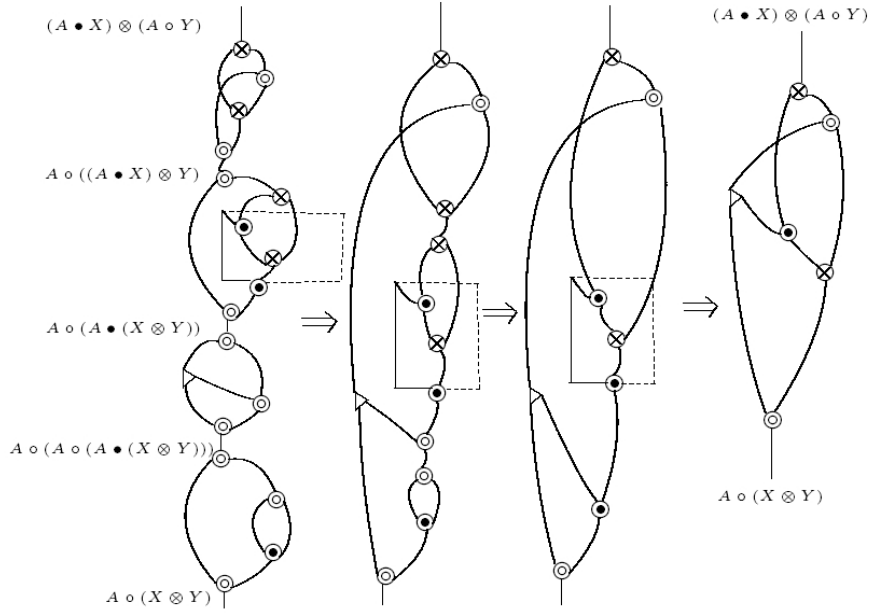

Figure 3.26: Circuit Diagram for v_{\oplus}^R

for \otimes and \circ , then the box-elimination rule. Finally, we get the resulting diagram by the reassociation of Δ and the circuit reduction rule for \otimes .

Figure 3.28 shows the circuit diagram for $a_{\otimes} (1 \otimes v_{\oplus}^R) v_{\oplus}^R$ (right side of the coherence condition). Here we use the circuit diagram for v_{\oplus}^R . We apply the circuit reduction rule for \otimes . Then by applying the circuit reduction rule for \otimes and \circ , we get the resulting diagram which is the same as Figure 3.27. So the coherence condition $(m_{\otimes} \otimes 1) v_{\oplus}^R (A \circ a_{\otimes}) = a_{\otimes} (1 \otimes v_{\oplus}^R) v_{\oplus}^R$ holds.

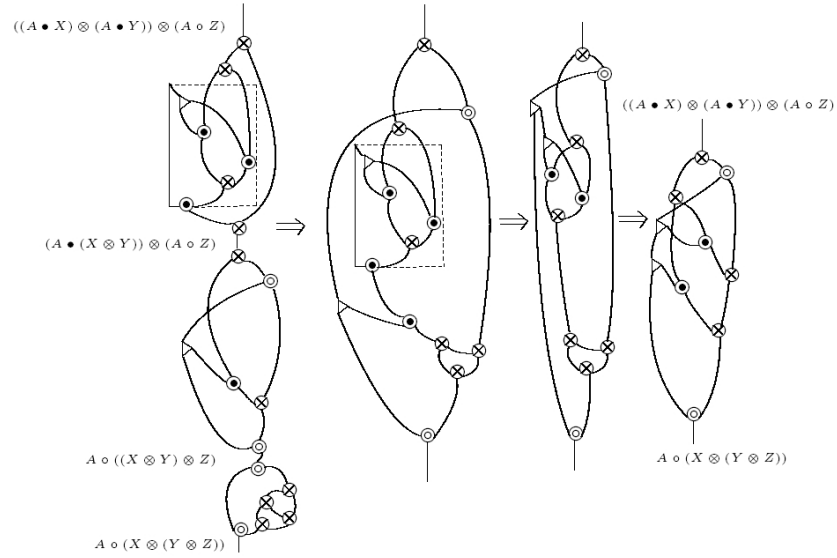

Figure 3.27: Circuit Diagram for $[(m_{\otimes} \otimes 1) v_{\oplus}^R (A \circ a_{\otimes})]$

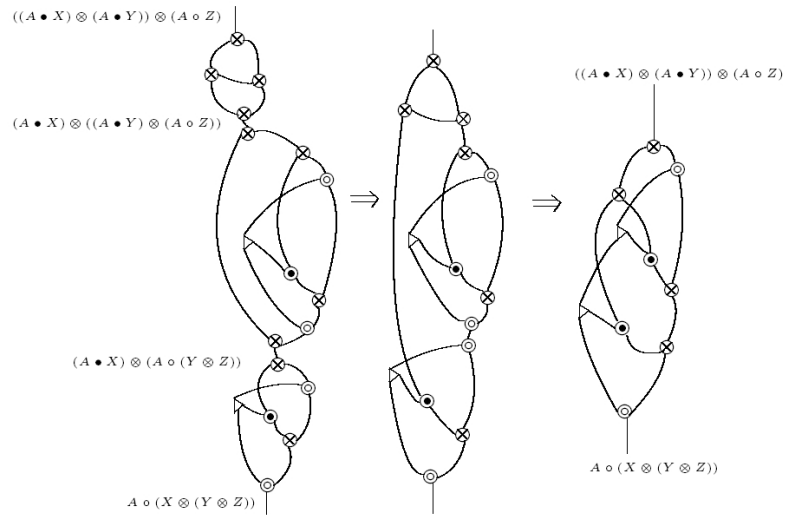

Figure 3.28: Circuit Diagram for $[a_{\otimes} (1 \otimes v_{\oplus}^R) v_{\oplus}^R]$

Finally, we will check the third coherence condition, $a_{\otimes} (1 \otimes v_{\oplus}^L) v_{\oplus}^R = (v_{\oplus}^R \otimes 1) v_{\oplus}^L (A \circ a_{\otimes})$.

$$\begin{array}{ccc}
 ((A \bullet X) \otimes (A \circ Y)) \otimes (A \bullet Z) & \xrightarrow{v_{\oplus}^R \otimes 1} & (A \circ (X \otimes Y)) \otimes (A \bullet Z) \\
 \downarrow a_{\otimes} & & \downarrow v_{\oplus}^L \\
 (A \bullet X) \otimes ((A \circ Y) \otimes (A \bullet Z)) & & A \circ ((X \otimes Y) \otimes Z) \\
 \downarrow 1 \otimes v_{\oplus}^L & & \downarrow A \circ a_{\otimes} \\
 (A \bullet X) \otimes (A \circ (Y \otimes Z)) & \xrightarrow{v_{\oplus}^R} & A \circ (X \otimes (Y \otimes Z))
 \end{array}$$

We shall verify this coherence condition by using circuit diagrams. In this case, we need the circuit diagram for v_{\oplus}^R that we discussed in Figure 3.26. We also need the circuit diagram for v_{\oplus}^L which is shown in Figure 3.29. In this figure, we apply circuit reduction rule for \circ first, then we apply circuit reduction rules for \otimes and \circ . Finally, we apply box-elimination rule and get the resulting diagram for v_{\oplus}^L . Here, the input is $(A \circ X) \otimes (A \bullet Y)$ and the output is $A \circ (X \otimes Y)$.

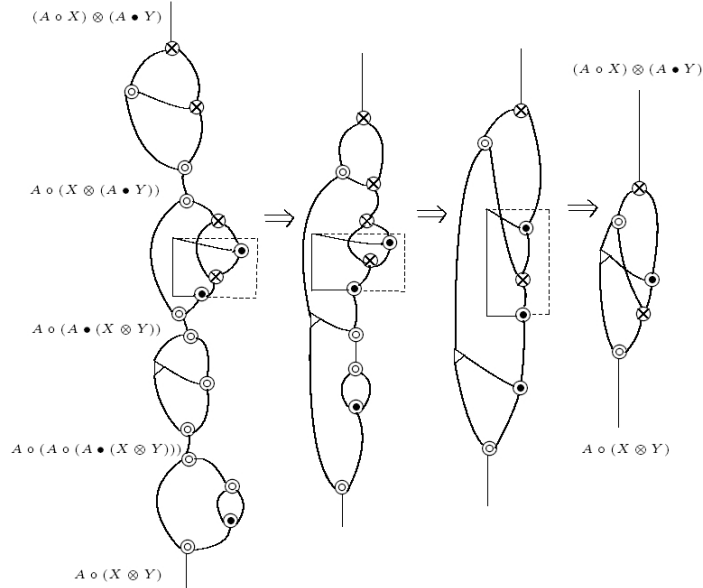

Figure 3.29: Circuit Diagram for v_{\oplus}^L

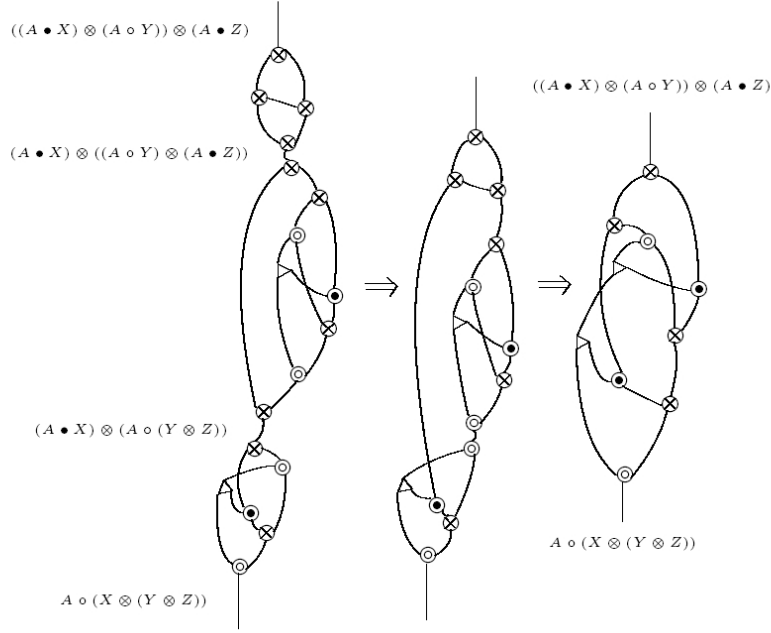

Figure 3.30: Circuit Diagram for $[a_{\otimes} (1 \otimes v_{\oplus}^L) v_{\oplus}^R]$

To verify the coherence condition, $a_{\otimes} (1 \otimes v_{\oplus}^L) v_{\oplus}^R = (v_{\oplus}^R \otimes 1) v_{\oplus}^L (A \circ a_{\otimes})$, the circuit diagram for $a_{\otimes} (1 \otimes v_{\oplus}^L) v_{\oplus}^R$ is shown in Figure 3.30 and the circuit diagram for $(v_{\oplus}^R \otimes 1) v_{\oplus}^L (A \circ a_{\otimes})$ is shown in Figure 3.31.

In Figure 3.30, we use the circuit diagrams for v_{\oplus}^L and v_{\oplus}^R . We apply the circuit reduction rule for \otimes first, then after applying the circuit reduction rules for \otimes and \circ , we get the resulting diagram.

In Figure 3.31, we also use the circuit diagrams for v_{\oplus}^L and v_{\oplus}^R . Here we first apply the circuit reduction rules for \otimes and \circ . Then we apply the circuit reduction rules for \circ and \otimes . Finally, we apply the circuit reduction rule for \otimes and we get the resulting diagram which is the same as the resulting diagram of Figure 3.30.

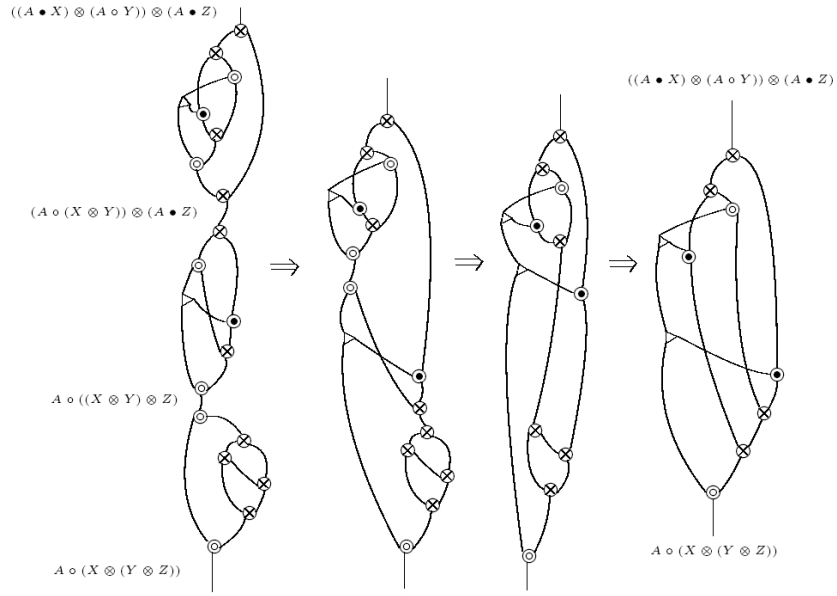

Figure 3.31: Circuit Diagram for $[(v_{\oplus}^R \otimes 1) v_{\oplus}^L (A \circ a_{\otimes})]$

So, the coherence condition, $a_{\otimes} (1 \otimes v_{\oplus}^L) v_{\oplus}^R = (v_{\oplus}^R \otimes 1) v_{\oplus}^L (A \circ a_{\otimes})$ holds. \square

Thus, every linear \mathbb{A} -actegory gives rise to a family of linear functors, $A \circ _$ and $A \bullet _$, $A \in \mathbb{A}$, where $A \bullet _$ is a monoidal functor, $A \circ _$ is a comonoidal functor and the linear strengths exist between these two functors which satisfy the coherence conditions.

Chapter 4

Fixed Points of Linear Functors

In this chapter, the fixed point of a linear functor is defined. This provides a very basic source of communication protocols for the concurrent world which have nice structural properties. Protocols, in general, are produced by considering inductive and coinductive data in linear categories. As a linear functor is a pair of functors, the fixed point of a linear functor is also expected to be a pair of functors: the pair is supplied by the inductive datatype built on the comonoidal functor and the coinductive datatype on the monoidal functor. This pair then itself forms a linear functor pair, which is the second main result of this thesis, Theorem 4.5.1. It shows that the fixed point of a linear functor is itself a linear functor.

The chapter starts by describing the initial and final algebras [19] which correspond to inductive and coinductive datatypes [10], [11], [23] respectively and the more sophisticated circular definitions for datatypes [13]. We examine some properties of these datatypes in Section 4.1-4.3.

4.1 Algebra definition of inductive and coinductive datatype

Given an endo-functor $F : \mathbb{X} \rightarrow \mathbb{X}$, an F -algebra consists of an object $A \in \mathbb{X}$ together with a morphism $a : F(A) \rightarrow A$. It is called initial if for any F -algebra $b : F(B) \rightarrow B$, there is a unique morphism $f : A \rightarrow B$ such that the following diagram commutes.

$$\begin{array}{ccc} F(A) & \xrightarrow{a} & A \\ F(f) \downarrow & & \downarrow f \\ F(B) & \xrightarrow{b} & B \end{array}$$

Dually, a F -coalgebra, $c : C \rightarrow F(C)$ is called final if for every coalgebra $d : D \rightarrow F(D)$,

there is a unique morphism $g : C \rightarrow D$ such that the following diagram commutes.

$$\begin{array}{ccc} C & \xrightarrow{c} & F(C) \\ \text{\scriptsize } g \downarrow \text{\scriptsize } & & \downarrow \text{\scriptsize } F(g) \\ D & \xrightarrow{d} & F(D) \end{array}$$

Initial algebras and final coalgebras [19] are equivalently known as inductive and coinductive datatypes in “set-like” and sequential settings as they can be constructed inductively and coinductively respectively. An inductive datatype for an endo-functor $F : \mathbb{X} \rightarrow \mathbb{X}$ is an object $\mu x.F(x)$ with a map $\text{cons} : F(\mu x.F(x)) \rightarrow \mu x.F(x)$ such that given any object $A \in \mathbb{X}$ and a map $f : F(A) \rightarrow A$, there exists a unique fold map such that the following diagram commutes.

$$\begin{array}{ccc} F(\mu x.F(x)) & \xrightarrow{\text{cons}} & \mu x.F(x) \\ \text{\scriptsize } F(\text{fold}(f)) \downarrow \text{\scriptsize } & & \downarrow \text{\scriptsize } \text{fold}(f) \\ F(A) & \xrightarrow{f} & A \end{array}$$

Dually, a coinductive datatype for F is an object $\nu x.F(x)$ with a map $\text{dest} : \nu x.F(x) \rightarrow F(\nu x.F(x))$ such that given any object $A \in \mathbb{X}$ and a map $f : A \rightarrow F(A)$, there exists a unique unfold map such that the following diagram commutes.

$$\begin{array}{ccc} A & \xrightarrow{f} & F(A) \\ \text{\scriptsize } \text{unfold}(f) \downarrow \text{\scriptsize } & & \downarrow \text{\scriptsize } F(\text{unfold}(f)) \\ \nu x.F(x) & \xrightarrow{\text{dest}} & F(\nu x.F(x)) \end{array}$$

Both the inductive and the coinductive datatypes of an endo-functor F are fixed points of F in the following sense.

Lemma 2. (See [19]) *If $F : \mathbb{X} \rightarrow \mathbb{X}$ is a functor for which $\mu x.F(x)$ exists then $\text{cons} : F(\mu x.F(x)) \rightarrow \mu x.F(x)$ is an isomorphism, i.e., $F(\mu x.F(x)) \cong \mu x.F(x)$ and (dually) if $\nu x.F(x)$ exists then $\text{dest} : \nu x.F(x) \rightarrow F(\nu x.F(x))$ is an isomorphism, i.e., $\nu x.F(x) \cong F(\nu x.F(x))$.*

Proof. In order to show that **cons** is an isomorphism, we have to produce an inverse function. It is the unique map h in the following diagram:

$$\begin{array}{ccc}
F(\mu x.F(x)) & \xrightarrow{\text{cons}} & \mu x.F(x) \\
F(h) \downarrow & & \downarrow h \\
F(F(\mu x.F(x))) & \xrightarrow{F(\text{cons})} & F(\mu x.F(x)) \\
F(\text{cons}) \downarrow & & \downarrow \text{cons} \\
F(\mu x.F(x)) & \xrightarrow{\text{cons}} & \mu x.F(x)
\end{array}$$

In this diagram, by the uniqueness property of inductive datatype, we have $h \text{ cons} = 1_{\mu x.F(x)}$. It then remains to show $\text{cons } h = 1_{F(\mu x.F(x))}$. But we have $\text{cons } h = F(h) F(\text{cons}) = F(h \text{ cons}) = F(1_{\mu x.F(x)}) = 1_{F(\mu x.F(x))}$ where we again use the fact that $h \text{ cons} = 1_{\mu x.F(x)}$.

We could prove $\nu x.F(x) \cong F(\nu x.F(x))$ dually. □

When F has an inductive datatype, we call $\mu x.F(x)$ the least fixed point of F . On the other hand, if F has a coinductive datatype then $\nu x.F(x)$ is called the greatest fixed point of F .

Parameterized functors give rise to parameterized datatypes [23]. Consider a parameterized functor $F : \mathbb{Y} \times \mathbb{X} \rightarrow \mathbb{X}$. By fixing the first argument of F , we get $F_A : \mathbb{X} \rightarrow \mathbb{X}$ for each object $A \in \mathbb{Y}$. So the fixed point of F_A is a parametric fixed point of F at A . This is $\mu x.F(A, x)$, the least fixed point of F_A , which satisfies the following universal diagram for any other F -algebra $f : F(A, X) \rightarrow X$:

$$\begin{array}{ccc}
F(A, \mu x.F(A, x)) & \xrightarrow{\text{cons}} & \mu x.F(A, x) \\
F(1, \text{fold}(f)) \downarrow & & \downarrow \text{fold}(f) \\
F(A, X) & \xrightarrow{f} & X
\end{array}$$

Setting $\overleftarrow{F}_A = \mu x.F(A, x)$, we next show that this parameterization is functorial (following [13]), i.e., identities and composition are preserved. In order to prove this, we shall use

the uniqueness property: given two maps $m, n : \mu x.F(A, x) \rightarrow Z$ if we want to show that $m = n$ it suffices to show that for a fixed $k : F(A, Z) \rightarrow Z$, $m = \text{fold}(k)$ and $n = \text{fold}(k)$. If $\text{cons } m = F(1, m) k$, then by uniqueness of $\text{fold}(k)$ we have $m = \text{fold}(k)$. Similarly, if $\text{cons } n = F(1, n) k$, then by uniqueness of $\text{fold}(k)$ we have $n = \text{fold}(k)$. This means, $m = n$.

Lemma 3. *If $F : \mathbb{Y} \times \mathbb{X} \rightarrow \mathbb{X}$ is a functor such that for each object $A \in \mathbb{Y}$, there exists $\overleftarrow{F}_A \in \mathbb{X}$, the least fixed point of F_A , then $A \mapsto \overleftarrow{F}_A : \mathbb{Y} \rightarrow \mathbb{X}$ forms a functor.*

Proof. Given a map $f : A \rightarrow B$, one can define $f : A \rightarrow B \mapsto \overleftarrow{F}(f) : \overleftarrow{F}_A \rightarrow \overleftarrow{F}_B$ such that $\overleftarrow{F}(f)$ is the unique fold map determined by the following diagram:

$$\begin{array}{ccc}
 F(A, \overleftarrow{F}_A) & \xrightarrow{\text{cons}} & \overleftarrow{F}_A \\
 \downarrow F(1, \overleftarrow{F}(f)) & & \downarrow \overleftarrow{F}(f) \\
 F(A, \overleftarrow{F}_B) & \xrightarrow{F(f, 1)} F(B, \overleftarrow{F}_B) \xrightarrow{\text{cons}} & \overleftarrow{F}_B
 \end{array}$$

The above diagram is the defining diagram of \overleftarrow{F} . First we check that identities are preserved: if $f = 1_A$, then $f : A \rightarrow A \mapsto \overleftarrow{F}(f) : \overleftarrow{F}_A \rightarrow \overleftarrow{F}_A$ such that the following diagram commutes:

$$\begin{array}{ccc}
 F(A, \overleftarrow{F}_A) & \xrightarrow{\text{cons}} & \overleftarrow{F}_A \\
 \downarrow F(1, \overleftarrow{F}(f)) & & \downarrow \overleftarrow{F}(f) \\
 F(A, \overleftarrow{F}_A) & \xrightarrow{\text{cons}} & \overleftarrow{F}_A
 \end{array}$$

From the above diagram, we have $F(1, \overleftarrow{F}(f)) \text{cons} = \text{cons } \overleftarrow{F}(f)$. By replacing $\overleftarrow{F}(f)$ with the identity, it follows that $\overleftarrow{F}(1_A) = 1_{\overleftarrow{F}(A)}$.

It remains to show that composition is preserved. This means

$$A \xrightarrow{f} B \xrightarrow{g} C \mapsto \overleftarrow{F}_A \xrightarrow{\overleftarrow{F}(f)} \overleftarrow{F}_B \xrightarrow{\overleftarrow{F}(g)} \overleftarrow{F}_C = A \xrightarrow{fg} C \mapsto \overleftarrow{F}_A \xrightarrow{\overleftarrow{F}(fg)} \overleftarrow{F}_C$$

We want to show that $\overleftarrow{F}(f) \overleftarrow{F}(g) = \overleftarrow{F}(fg)$. To achieve this it suffices to show that both maps satisfy the same universal property.

First, we have to show that for a fixed k , $\overleftarrow{F}(f) \overleftarrow{F}(g) = \text{fold } k$.

$$\begin{array}{ccccc}
F(A, \overleftarrow{F}_A) & \xrightarrow{\text{cons}} & & \overleftarrow{F}_A & \\
\downarrow F(1, \overleftarrow{F}(f)) & & (1) & \downarrow \overleftarrow{F}(f) & \\
F(A, \overleftarrow{F}_B) & \xrightarrow{F(f,1)} & F(B, \overleftarrow{F}_B) & \xrightarrow{\text{cons}} & \overleftarrow{F}_B \\
\downarrow F(1, \overleftarrow{F}(f)) & & \downarrow F(1, \overleftarrow{F}(f)) & (3) & \downarrow \overleftarrow{F}_g \\
F(A, \overleftarrow{F}_C) & \xrightarrow{F(f,1)} & F(B, \overleftarrow{F}_C) & \xrightarrow{F(g,1)} & F(C, \overleftarrow{F}_C) \xrightarrow{\text{cons}} \overleftarrow{F}_C
\end{array}$$

In this diagram, (1) and (3) commute by the defining diagram of $\overleftarrow{F}(f)$ and (2) commutes because of the functoriality of F . So we get $\overleftarrow{F}(f) \overleftarrow{F}(g) = \text{fold}[F(f, 1) F(g, 1) \text{cons}]$ where, $k = F(f, 1) F(g, 1) \text{cons}$.

Next we have to show that for a fixed k , $\overleftarrow{F}(fg) = \text{fold } k$.

$$\begin{array}{ccc}
F(A, \overleftarrow{F}_A) & \xrightarrow{\text{cons}} & \overleftarrow{F}_A \\
\downarrow F(1, \overleftarrow{F}(fg)) & & \downarrow \overleftarrow{F}(fg) \\
F(A, \overleftarrow{F}_C) & \xrightarrow{F(fg,1)} & F(C, \overleftarrow{F}_C) \xrightarrow{\text{cons}} \overleftarrow{F}_C
\end{array}$$

This diagram commutes by the defining diagram of \overleftarrow{F} . Here, $\overleftarrow{F}(fg) = \text{fold}[F(fg, 1) \text{cons}] = \text{fold}[F(f, 1)F(g, 1) \text{cons}]$ (as F preserves composition). Thus, $\overleftarrow{F}(f) \overleftarrow{F}(g) = \overleftarrow{F}(fg)$.

□

4.2 Circular definition of inductive and coinductive datatype

There is an alternative method of defining the universal property of inductive and coinductive data which uses the notion of a circular combinator; the idea was used by Varmo Vene [29] and Luigi Santocanale [26], [27]. A **circular combinator** for an endofunctor $F : \mathbb{X} \rightarrow \mathbb{X}$ over D is an assignment.

$$\frac{A \xrightarrow{f} D}{F(A) \xrightarrow{c[f]} D} c[-]$$

which given a map, $f : A \rightarrow D$, delivers a new map $c[f] : F(A) \rightarrow D$ such that the following implication of commutative triangles holds:

$$\begin{array}{ccc}
 A & \xrightarrow{h} & A' \\
 & \searrow f & \swarrow f' \\
 & & D
 \end{array}
 \quad \Rightarrow \quad
 \begin{array}{ccc}
 F(A) & \xrightarrow{F(h)} & F(A') \\
 & \searrow c[f] & \swarrow c[f'] \\
 & & D
 \end{array}$$

The inductive datatype $\mu x.F(x)$ with its constructor $\text{cons} : F(\mu x.F(x)) \rightarrow \mu x.F(x)$ may then be defined as having the following universal property: for any circular combinator $c[_]$ of F over D , there exists a unique map $\mu a.c[a]$, the ‘‘circular fold map’’; such that the following diagram commutes.

$$\begin{array}{ccc}
 F(\mu x.F(x)) & \xrightarrow{\text{cons}} & \mu x.F(x) \\
 c[\mu a.c[a]] \downarrow & & \swarrow \mu a.c[a] \\
 & & D
 \end{array}$$

Dually, the coinductive datatype $\nu x.F(x)$ with its destructor $\text{dest} : \nu x.F(x) \rightarrow F(\nu x.F(x))$ may then be defined as having the following universal property: for any cocircular combinator $c[_]$ of F under D , there exists a unique map $\nu b.c[b]$, the ‘‘circular unfold map’’; such that the following diagram commutes.

$$\begin{array}{ccc}
 D & \xrightarrow{\nu b.c[b]} & \nu x.F(x) \\
 c[\nu b.c[b]] \downarrow & & \swarrow \text{dest} \\
 & & F(\nu x.F(x))
 \end{array}$$

Lemma 4. (See [13]) *Circular combinators for F over D correspond precisely to F -algebras on D . Given an F -algebra $f : F(D) \rightarrow D$ one obtains a circular combinator, $c_f[_]$ and conversely, given a circular combinator $c[_]$ one obtains an F -algebra, $c[1_D] : F(D) \rightarrow D$.*

Proof. If $f : F(D) \rightarrow D$ is an F -algebra, then a circular combinator, $c_f[g]$ is defined as follows:

$$\frac{A \xrightarrow{g} D}{F(A) \xrightarrow{F(g)} F(D) \xrightarrow{f} D} \mathbf{c}_f$$

So $\mathbf{c}_f[g] = F(g)f$ and the following implication holds.

$$\begin{array}{ccc} A & \xrightarrow{h} & A' \\ & \searrow g & \swarrow g' \\ & & D \end{array} \quad \Rightarrow \quad \begin{array}{ccccc} F(A) & \xrightarrow{F(h)} & & F(A') & \\ & \searrow F(g) & & \swarrow F(g') & \\ & & F(D) & & \\ & \searrow \mathbf{c}_f[g] & \downarrow f & \swarrow \mathbf{c}_f[g'] & \\ & & D & & \end{array}$$

Conversely, a circular combinator, $\mathbf{c}[_]$ defines an F -algebra as follows:

$$\frac{D \xrightarrow{1} D}{F(D) \xrightarrow{\mathbf{c}[1_D]} D} \mathbf{c}$$

So $\mathbf{c} = \mathbf{c}_{\mathbf{c}[1_D]}$. Note that $\mathbf{c}_f[1] = f$. □

Proposition 4.2.1. (See [13]) *The algebraic definition and the circular definition of datatypes are equivalent.*

Proof. Given $\mu x.F(x)$ satisfying the algebra definition of an inductive datatype, we must show it satisfies the circular definition of the datatype. If $\mu x.F(x)$ is an inductive datatype, then for any F -algebra $f : F(D) \rightarrow D$ the following diagram commutes.

$$\begin{array}{ccc} F(\mu x.F(x)) & \xrightarrow{\text{cons}} & \mu x.F(x) \\ F(\text{fold}(f)) \downarrow & & \downarrow \text{fold}(f) \\ F(D) & \xrightarrow{f} & D \end{array}$$

From this diagram, we get $F(\text{fold}(f))f = \text{cons}(\text{fold}(f))$. Given a circular combinator $\mathbf{c}[_]$ of F over D one may extract an algebra $f = \mathbf{c}[1_D] : F(D) \rightarrow D$. Then we get $\mu a.\mathbf{c}[a] = \text{fold}(f)$ and the following circular diagram:

$$\begin{array}{ccc}
\mu x.F(x) & \xrightarrow{\text{fold}(f)} & D \\
& \searrow \text{fold}(f) & \nearrow 1 \\
& & D
\end{array}
\quad \Rightarrow \quad
\begin{array}{ccc}
F(\mu x.F(x)) & \xrightarrow{F(\text{fold}(f))} & F(D) \\
& \searrow c[\text{fold}(f)] & \nearrow f \\
& & D
\end{array}$$

Thus, $\text{fold}(f)$ satisfies the properties required by the unique induced circular map $\mu a.c[a]$.

Conversely, if $\mu x.F(x)$ holds the circular definition of an inductive datatype, then it must satisfy the algebra definition. Given an F -algebra $f : F(D) \rightarrow D$ one can define a circular combinator $c[-]$ such that

$$\begin{array}{ccc}
F(\mu x.F(x)) & \xrightarrow{\text{cons}} & \mu x.F(x) \\
F(h) \downarrow & \searrow c[h] & \downarrow h \\
F(D) & \xrightarrow{f} & D
\end{array}$$

Here, $h = \mu a.c[a]$ and $c[h] = F(h)f$ as $c[-]$ is a combinator.

□

4.3 Circular rules

We may formulate datatypes type theoretically using circular rules in a manner which is reminiscent of the way one writes a recursive program. Given a map, $f : X \rightarrow D$, having a circular combinator says that one can derive a map $F(X) \rightarrow D$: this says there exists a unique circular $\text{fold} : \mu x.F(x) \rightarrow D$ map. The following scheme shows the derivation of a circular fold map where the object D is fixed but f and X can vary.

$$\boxed{
\begin{array}{c}
\forall X \qquad f : X \rightarrow D \\
\hline
\frac{X \rightarrow D}{F(X) \rightarrow D} \\
\hline
\mu x.F(x) \rightarrow D
\end{array}
}$$

For $\text{cons} : F(\mu x.F(x)) \rightarrow \mu x.F(x)$, if a map, $f : X \rightarrow F(\mu x.F(x))$ is given, then we can derive $\text{cons}[f]$ as follows:

$$\frac{X \xrightarrow{f} F(\mu x.F(x))}{X \xrightarrow{\text{cons}[f]} \mu x.F(x)}$$

Similarly, we get a unique circular **unfold** : $D \rightarrow \nu x.F(x)$ map if for a given map, $f : D \rightarrow X$, it is possible to derive a map, $D \rightarrow F(X)$ by applying a cocircular combinator.

The derivation of a circular **unfold** map is as follows:

$$\frac{\frac{\forall X \quad f : D \rightarrow X}{\frac{D \rightarrow X}{D \rightarrow F(X)}}}{D \rightarrow \nu x.F(x)}$$

For $\text{dest} : \nu x.F(x) \rightarrow F(\nu x.F(x))$, given a map, $f : F(\nu x.F(x)) \rightarrow X$, one can derive $\text{dest}[f]$ as follows:

$$\frac{F(\nu x.F(x)) \xrightarrow{f} X}{\nu x.F(x) \xrightarrow{\text{dest}[f]} X}$$

For example, consider the set of natural numbers, \mathbb{N} with $\text{zero} : 1 \rightarrow \mathbb{N}$ and $\text{succ} : \mathbb{N} \rightarrow \mathbb{N}$ constructors. Then for the functor of natural numbers, $1 + _$, we get the following map:

$$1 + \mathbb{N} \xrightarrow{[\text{zero}, \text{succ}]} \mathbb{N}$$

such that the following diagram commutes.

$$\begin{array}{ccc} 1 + \mathbb{N} & \xrightarrow{[\text{zero}, \text{succ}]} & \mathbb{N} \\ \downarrow 1+f & & \downarrow f \\ 1 + U & \xrightarrow{[u, h]} & U \end{array}$$

The above map forms an inductive datatype which uses the property of the coproduct structure. So the datatype for natural numbers is written as:

$$\begin{aligned} \text{data nat } \rightarrow \mathbb{N} = & \text{zero} : 1 \rightarrow \mathbb{N} \\ & | \text{succ} : \mathbb{N} \rightarrow \mathbb{N} \end{aligned}$$

The above diagram can be expressed as follows:

$$\begin{array}{ccc} 1 & \xrightarrow{\text{zero}} & \mathbb{N} & \xleftarrow{\text{succ}} & \mathbb{N} \\ \parallel & & \downarrow f & & \downarrow f \\ 1 & \xrightarrow{u} & U & \xleftarrow{h} & U \end{array}$$

By using the circular combinator, we get

$$\frac{\frac{\forall X \quad X \vdash_f U}{1 \vdash_u U \quad X \vdash_{fh} U}}{1 + X \vdash U}}{\mathbb{N} \vdash_g U}$$

Here, g gives the circular fold map for natural numbers.

For the list functor, $L(A) = \mu x. 1 + A \times x$, the constructor is $[\text{nil}, \text{cons}] : 1 + A \times L(A) \rightarrow L(A)$ which satisfies the following universal property:

$$\begin{array}{ccc} 1 + (A \times L(A)) & \xrightarrow{[\text{nil}, \text{cons}]} & L(A) \\ \downarrow 1+(1 \times f) & & \downarrow f \\ 1 + (A \times B) & \xrightarrow{[u, h]} & B \end{array}$$

The datatype for finite lists may be defined by the form of its fold map:

$$\begin{aligned} \text{data } L(A) \rightarrow C = & \text{nil} : 1 \rightarrow C \\ & | \text{cons} : A \times C \rightarrow C \end{aligned}$$

To get the types of the constructors, one can replace C by $L(A)$. Then the constructors for list will be:

$$\begin{aligned} \text{nil} &: 1 \rightarrow L(A) \\ \text{cons} &: A \times L(A) \rightarrow L(A) \end{aligned}$$

Here the `nil` constructor produces an empty list and the `cons` constructor prepends an element of type A to a list of type $L(A)$ to produce a list. For example, $[1, 2, 3] = \text{cons}(1, \text{cons}(2, \text{cons}(3, \text{nil}())))$.

As the list datatype uses the coproduct structure the above universal property for list can be written diagrammatically as:

$$\begin{array}{ccccc} 1 & \xrightarrow{\text{nil}} & L(A) & \xleftarrow{\text{cons}} & A \times L(A) \\ \parallel & & \downarrow f & & \downarrow 1 \times f \\ 1 & \xrightarrow{u} & B & \xleftarrow{h} & A \times B \end{array}$$

Using the circular definition,

$$\frac{\frac{\forall X \quad A \times X \vdash_f B}{1 \vdash_u B \quad A \times X \vdash_{fh} B}}{1 + A \times X \vdash B}}{L(A) \vdash_g B}$$

As an example of fold on list, we can consider length function that returns an integer as the length of a finite list and we can write it as:

$$\text{len}(y) = \{\text{nil} \mapsto \text{zero} \mid \text{cons } y \text{ } ys \mapsto \text{succ}(\text{len } ys)\}$$

where y refers to the first element of a list while ys refers to the rest of the elements of a list.

In Section 4.5, the circular definition is used to get fixed points in linearly distributive categories. In this case, we want the following circular fold map where Γ is the context.

$$\frac{\forall X \quad \Gamma, X \vdash \Delta}{\frac{\Gamma, X \vdash \Delta}{\Gamma, F(X) \vdash \Delta} \text{c}[-]} \Gamma, \mu x.F(x) \vdash \Delta$$

In the algebra definition of **fold**, we have to specify an algebra, $f : F(A) \rightarrow A$, in order to obtain a unique **fold** map $\mu x.F(x) \rightarrow A$. In the circular definition, we just need to have an inference between maps rather than an explicit algebra. These two definitions are equivalent in the basic setting, as proven above. However, in the presence of contexts this equivalence breaks down. In the linearly distributive case one needs to have a circular combinator in a particular two-sided context. When the linearly distributive category has duals (i.e., it is $*$ -autonomous) then it is possible to manipulate the context out of the way: however, in general, a linearly distributive category need not be $*$ -autonomous so that the circular form of the definition becomes essential.

Explicitly, consider the $*$ -autonomous case. One is allowed to flip formulae from left side to right side and from right side to left side of sequents by “negating” it. Thus:

$$\frac{X, \Gamma \vdash \Delta}{\Gamma \vdash X^*, \Delta}$$

$$\frac{\Gamma \vdash X, \Delta}{X^*, \Gamma \vdash \Delta}$$

This means that in a $*$ -autonomous category, from a circular combinator, one can still recover an algebra. Given a circular combinator:

$$\frac{\Gamma, X \vdash \Delta}{\Gamma, F(X) \vdash \Delta} \text{c}[-]$$

we get the following circular **fold** map in a $*$ -autonomous category.

$$\frac{\forall X \quad \frac{\frac{\frac{X \vdash \Gamma^*, \Delta}{\Gamma, X \vdash \Delta}}{\Gamma, F(X) \vdash \Delta} \text{c}[-]}{F(X) \vdash \Gamma^*, \Delta}}{\mu x.F(x) \vdash \Gamma^*, \Delta}}{\Gamma, \mu x.F(x) \vdash \Delta}$$

However, in a linearly distributive setting, we can not express the passage above because a linearly distributive category does not allow flipping of formulae. So, the only way to express this is to use circular rules.

4.4 Fixed point of a monoidal functor

Suppose $F : \mathbb{Y} \times \mathbb{X} \rightarrow \mathbb{X}$ is a parameterized monoidal functor that takes a pair of objects (Y, X) to X , where $Y \in \mathbb{Y}$ and $X \in \mathbb{X}$, and a pair of morphisms $(f, g) : (Y, X) \rightarrow (Y', X')$ to g , where $f : Y \rightarrow Y'$ and $g : X \rightarrow X'$. If $\nu x.F(Y, x)$ is the greatest fixed point of F , then $Y \mapsto \nu x.F(Y, x) : \mathbb{Y} \rightarrow \mathbb{X}$. Let $\vec{F} = \nu x.F(-, x)$. Dually, the least fixed point of F is $\mu x.F(Y, x)$ which can be written as $\overleftarrow{F} = \mu x.F(-, x)$.

Given a map, $f : A \rightarrow B$, $\vec{F}(f) : \vec{F}(A) \rightarrow \vec{F}(B)$ is the unique **unfold** map which is determined by

$$\begin{array}{ccccc}
\vec{F}(A) & \xrightarrow{\text{dest}} & F(A, \vec{F}(A)) & \xrightarrow{F(f, 1)} & F(B, \vec{F}(A)) \\
& \searrow^{\vec{F}(f)} & & & \downarrow F(1, \vec{F}(f)) \\
& & \vec{F}(B) & \xrightarrow{\text{dest}} & F(B, \vec{F}(B))
\end{array}$$

This diagram is the defining diagram of \vec{F} .

Given two maps h and k where $h, k : X \rightarrow \vec{F}(A)$. In order to prove that $h = k$, it suffices to show that for a fixed $g : X \rightarrow F(A, X)$, $h = \text{unfold}(g)$ and $k = \text{unfold}(g)$. If

$h \text{ dest} = g F(1, h)$ then; by uniqueness of $\text{unfold}(g)$, we have $h = \text{unfold}(g)$. Similarly, if $k \text{ dest} = g F(1, k)$ then; by uniqueness of $\text{unfold}(g)$, we have $k = \text{unfold}(g)$. So $h = k$. In Proposition 4.4.1 this property is used to prove that the two maps are equal.

Proposition 4.4.1. *The greatest fixed point \vec{F} of a monoidal functor F is monoidal.*

Proof. For the greatest fixed point \vec{F} of a monoidal functor F to be monoidal there must be the following two natural transformations:

$$\begin{aligned}\vec{m} : \vec{F}(A) \otimes \vec{F}(B) &\rightarrow \vec{F}(A \otimes B) \\ \vec{m}_\top : \top &\rightarrow \vec{F}(\top)\end{aligned}$$

which will satisfy two equations:

$$\begin{aligned}(\vec{m}_\top \otimes 1) \vec{m} \vec{F}(l_\otimes) &= l_\otimes \\ a_\otimes (1 \otimes \vec{m}) \vec{m} &= (\vec{m} \otimes 1) \vec{m} \vec{F}(a_\otimes)\end{aligned}$$

So in order to prove that \vec{F} is a monoidal functor, we have to show that the following two diagrams commute.

$$\begin{array}{ccc} \top \otimes \vec{F}(A) & \xrightarrow{\vec{m}_\top \otimes 1} & \vec{F}(\top) \otimes \vec{F}(A) \\ l_\otimes \downarrow & & \downarrow \vec{m} \\ \vec{F}(A) & \xleftarrow{\vec{F}(l_\otimes)} & \vec{F}(\top \otimes A) \end{array}$$

$$\begin{array}{ccc} (\vec{F}(A) \otimes \vec{F}(B)) \otimes \vec{F}(A) & \xrightarrow{a_\otimes} & \vec{F}(A) \otimes (\vec{F}(B) \otimes \vec{F}(C)) \\ \vec{m} \otimes 1 \downarrow & & \downarrow 1 \otimes \vec{m} \\ \vec{F}(A \otimes B) \otimes \vec{F}(A) & & \vec{F}(A) \otimes \vec{F}(B \otimes C) \\ \vec{m} \downarrow & & \downarrow \vec{m} \\ \vec{F}((A \otimes B) \otimes C) & \xrightarrow{\vec{F}(a_\otimes)} & \vec{F}(A \otimes (B \otimes C)) \end{array}$$

We start by defining \vec{m} and \vec{m}_\top .

$$\begin{array}{ccc}
\vec{F}(A) \otimes \vec{F}(B) & \xrightarrow{\text{dest} \otimes \text{dest}} & F(A, \vec{F}(A)) \otimes F(B, \vec{F}(B)) \xrightarrow{m_\otimes} F(A \otimes B, \vec{F}(A) \otimes \vec{F}(B)) \\
& \searrow \vec{m} & \downarrow F(1, \vec{m}) \\
& & \vec{F}(A \otimes B) \xrightarrow{\text{dest}} F(A \otimes B, \vec{F}(A \otimes B)) \\
& & \downarrow \\
& & \top \xrightarrow{m_\top} F(\top, \top) \\
& & \downarrow F(1, \vec{m}_\top) \\
& & \vec{F}(\top) \xrightarrow{\text{dest}} F(\top, \vec{F}(\top))
\end{array}$$

Now we will check the first equation, $(\vec{m}_\top \otimes 1) \vec{m} \vec{F}(l_\otimes) = l_\otimes$. To prove this equation holds, it suffices to show that for a fixed g , $(\vec{m}_\top \otimes 1) \vec{m} \vec{F}(l_\otimes) = \text{unfold}(g)$ and $l_\otimes = \text{unfold}(g)$. The diagram for $(\vec{m}_\top \otimes 1) \vec{m} \vec{F}(l_\otimes) = \text{unfold}(g)$ is shown in Figure 4.1. In this figure, cell (1) commutes by tensor (\otimes) functor, cell (2) commutes because of the defining diagram of \vec{m}_\top , cell (3) commutes by the naturality of m_\otimes , cell (4) and (6) commute by the functoriality of F , cell (5) commutes because of the defining diagram of \vec{m} and cell (7) commutes by the defining diagram of \vec{F} . So we get $[(\vec{m}_\top \otimes 1) \vec{m} \vec{F}(l_\otimes)] \text{dest} = [(m_\top \otimes \text{dest}) m_\otimes F(l_\otimes, 1)] F(1, [(\vec{m}_\top \otimes 1) \vec{m} \vec{F}(l_\otimes)])$. Then by uniqueness of unfold , $(\vec{m}_\top \otimes 1) \vec{m} \vec{F}(l_\otimes) = \text{unfold}[(m_\top \otimes \text{dest}) m_\otimes F(l_\otimes, 1)]$.

The diagram for $l_\otimes = \text{unfold}(g)$ is shown in Figure 4.2. In this figure, cell (1) commutes by the naturality of l_\otimes , cell (2) commutes because F is monoidal, cell (3) commutes by the functoriality of F . So we get, $l_\otimes \text{dest} = [(m_\top \otimes \text{dest}) m_\otimes F(l_\otimes, 1)] F(1, l_\otimes)$. Then by uniqueness of unfold , $l_\otimes = \text{unfold}[(m_\top \otimes \text{dest}) m_\otimes F(l_\otimes, 1)]$.

Now we will show that the second equation, $a_\otimes (1 \otimes \vec{m}) \vec{m} = (\vec{m} \otimes 1) \vec{m} \vec{F}(a_\otimes)$ holds. To prove this equation holds, it suffices to show that for a fixed g , $a_\otimes (1 \otimes \vec{m}) \vec{m} = \text{unfold}(g)$ and $(\vec{m} \otimes 1) \vec{m} \vec{F}(a_\otimes) = \text{unfold}(g)$. In Figure 4.3, the diagram for $a_\otimes (1 \otimes \vec{m}) \vec{m} = \text{unfold}(g)$ is shown. In this figure, cell (1) commutes by the naturality of m_\otimes , cell (2) and (3) commute because of tensor (\otimes) functor, cell (4) commutes because F is monoidal, validity of cell (5) is

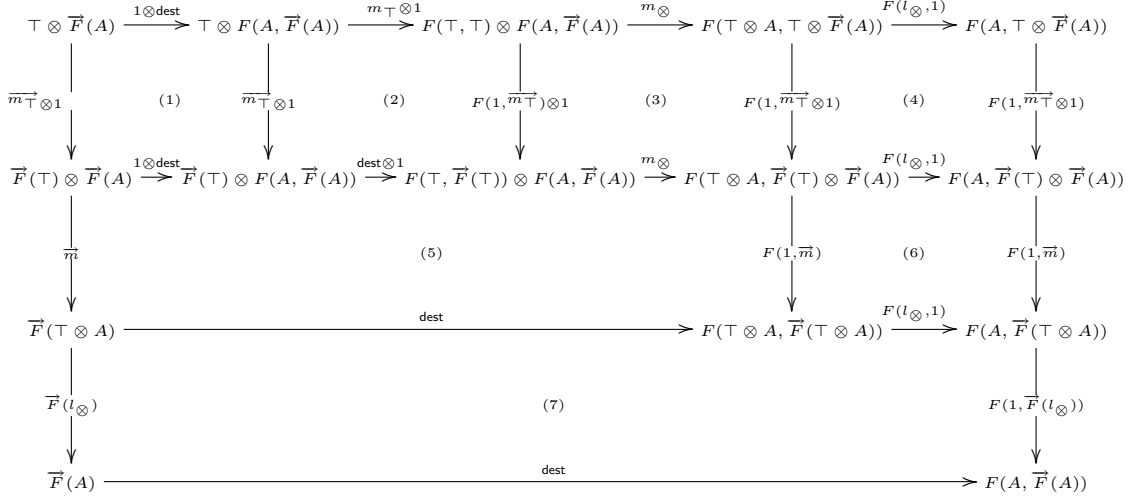

Figure 4.1: $(\overrightarrow{m}_T \otimes 1) \overrightarrow{m} \overrightarrow{F}(l_\otimes) = \text{unfold}(g)$

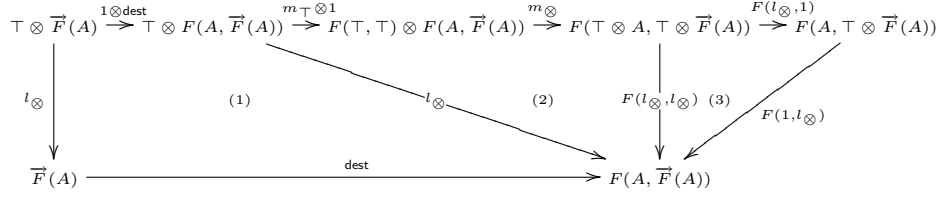

Figure 4.2: $l_\otimes = \text{unfold}(g)$

shown in Figure 4.4, cell (6) commutes by the defining diagram of \overrightarrow{m} . So, $a_\otimes (1 \otimes \overrightarrow{m}) \overrightarrow{m} = \text{unfold}[\text{((dest} \otimes \text{dest)} \otimes 1) (m_\otimes \otimes 1) (1 \otimes \text{dest}) m_\otimes]$. In Figure 4.4, cell (1), (2), (4) and (6) commute because of tensor (\otimes) functor, cell (3) commutes by the defining diagram of \overrightarrow{m} , cell (5) commutes by the naturality of m_\otimes .

The diagram for $(\overrightarrow{m} \otimes 1) \overrightarrow{m} \overrightarrow{F}(a_\otimes) = \text{unfold}(g)$ is shown in Figure 4.5. In this figure, cell (1) and (4) commute because of the defining diagram of \overrightarrow{m} , cell (2) commutes because of tensor (\otimes) functor, cell (3) commutes by the naturality of m_\otimes , cell (5) commutes by the defining diagram of \overrightarrow{F} . So $(\overrightarrow{m} \otimes 1) \overrightarrow{m} \overrightarrow{F}(a_\otimes) = \text{unfold}[\text{((dest} \otimes \text{dest)} \otimes 1) (m_\otimes \otimes 1) (1 \otimes \text{dest}) m_\otimes]$.

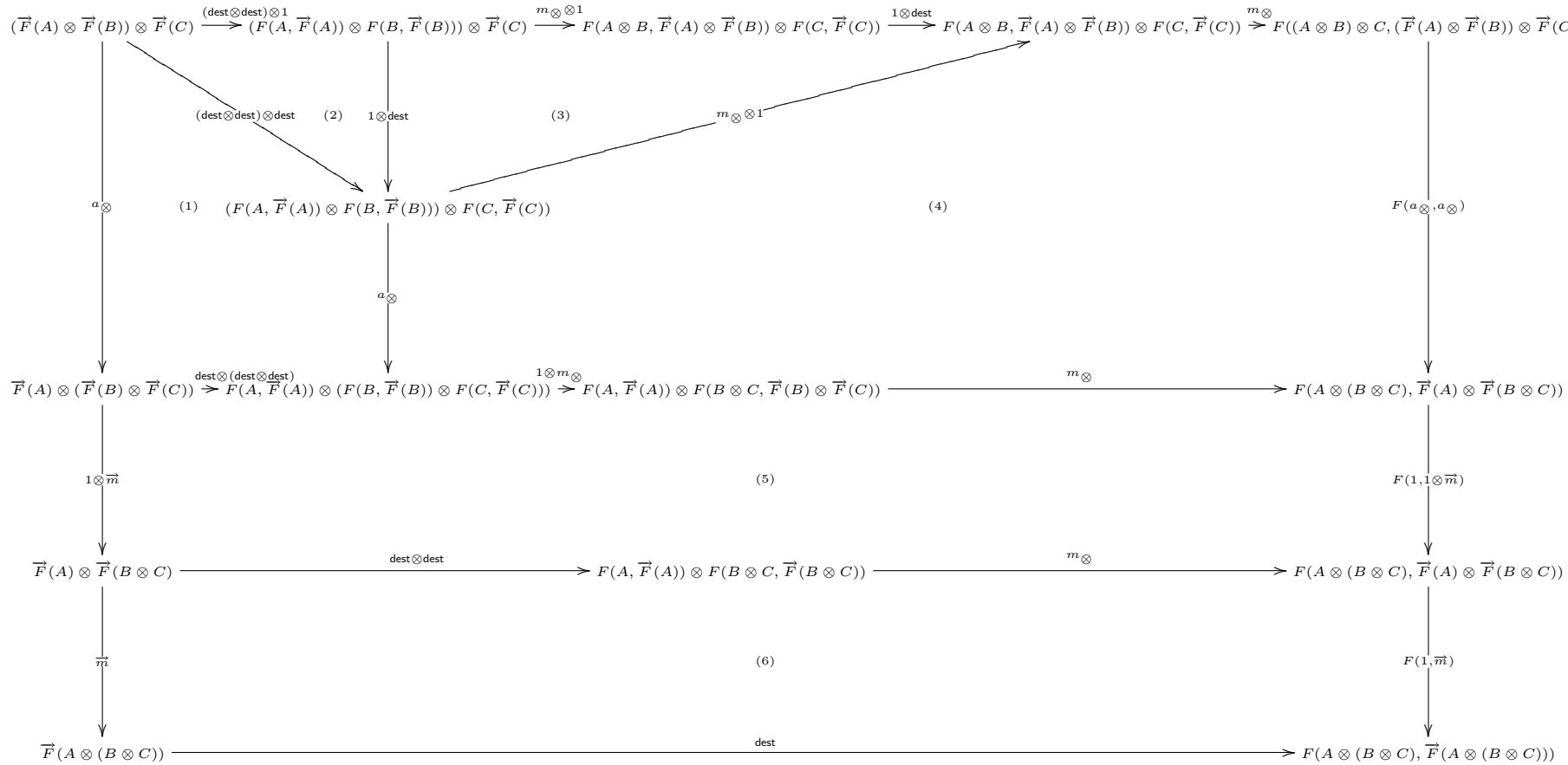

Figure 4.3: $a_{\otimes} (1 \otimes \vec{m}) \vec{m} = \text{unfold}(g)$

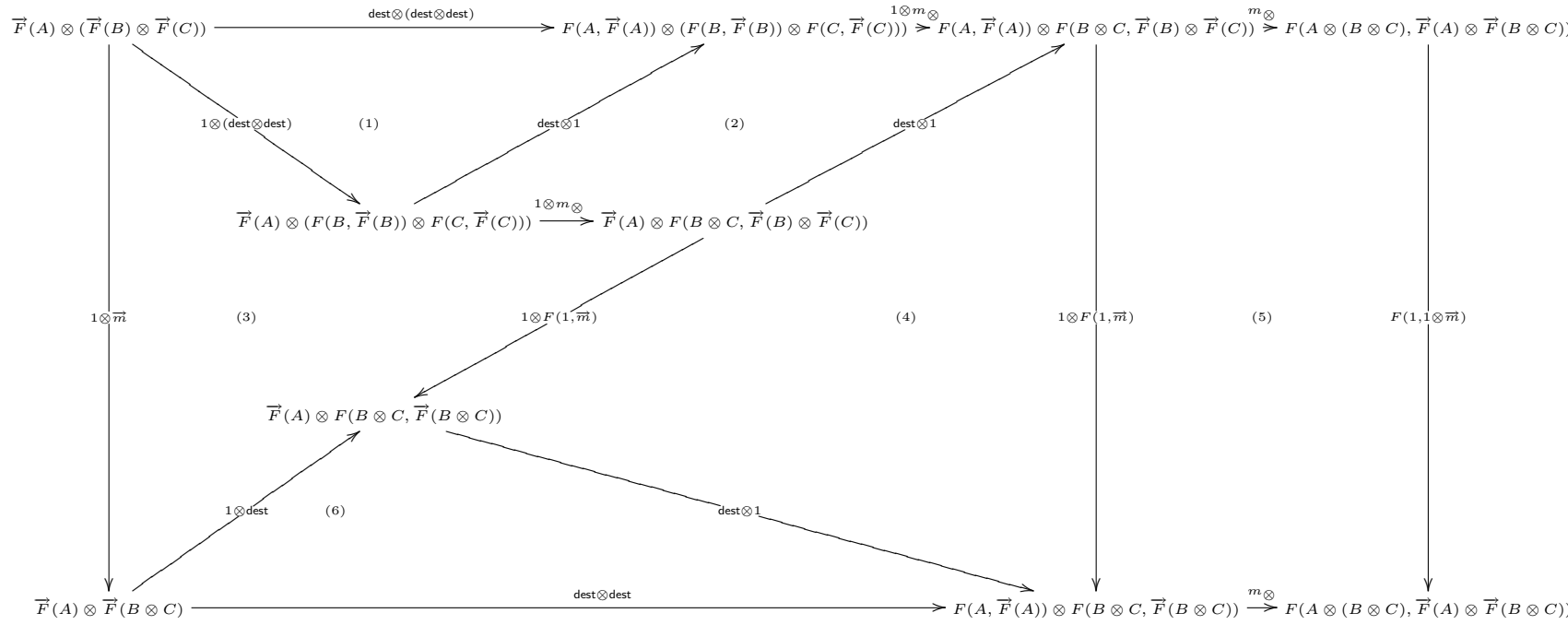

Figure 4.4: Validity of diagram (5) from Figure 4.3

$$\begin{array}{c}
(\vec{F}(A) \otimes \vec{F}(B)) \otimes \vec{F}(C) \xrightarrow{(\text{dest} \otimes \text{dest}) \otimes 1} (F(A, \vec{F}(A)) \otimes F(B, \vec{F}(B))) \otimes \vec{F}(C) \xrightarrow{m \otimes 1} F(A \otimes B, \vec{F}(B \otimes C)) \otimes \vec{F}(C) \xrightarrow{1 \otimes \text{dest}} F(A \otimes B, \vec{F}(B \otimes C)) \otimes F(C, \vec{F}(C)) \xrightarrow{m \otimes} F((A \otimes B) \otimes C, (\vec{F}(A) \otimes \vec{F}(B)) \otimes \vec{F}(C)) \\
\downarrow \vec{m} \otimes 1 \qquad \qquad \qquad (1) \qquad \qquad \qquad \downarrow F(1, \vec{m}) \otimes 1 \qquad \qquad \qquad (2) \qquad \qquad \qquad \downarrow F(1, \vec{m}) \otimes 1 \qquad \qquad \qquad (3) \qquad \qquad \qquad \downarrow F(1, \vec{m}) \otimes 1 \\
\vec{F}(A \otimes B) \otimes \vec{F}(C) \xrightarrow{\text{dest} \otimes 1} F(A \otimes B, \vec{F}(A \otimes B)) \otimes \vec{F}(C) \xrightarrow{1 \otimes \text{dest}} F(A \otimes B, \vec{F}(A \otimes B)) \otimes F(C, \vec{F}(C)) \xrightarrow{m \otimes} F((A \otimes B) \otimes C, \vec{F}(A \otimes B) \otimes \vec{F}(C)) \\
\downarrow \vec{m} \qquad \qquad \qquad (4) \qquad \qquad \qquad \downarrow F(1, \vec{m}) \\
\vec{F}((A \otimes B) \otimes C) \xrightarrow{\text{dest}} F((A \otimes B) \otimes C, \vec{F}((A \otimes B) \otimes C)) \\
\downarrow \vec{F}(a_{\otimes}) \qquad \qquad \qquad (5) \qquad \qquad \qquad \downarrow F(a_{\otimes}, \vec{F}(a_{\otimes})) \\
\vec{F}(A \otimes (B \otimes C)) \xrightarrow{\text{dest}} F(A \otimes (B \otimes C), \vec{F}(A \otimes (B \otimes C)))
\end{array}$$

Figure 4.5: $(\vec{m} \otimes 1) \vec{m} \vec{F}(a_{\otimes}) = \text{unfold}(g)$

Thus, the greatest fixed point \overrightarrow{F} of a monoidal functor F is monoidal as it satisfies all the conditions to become a monoidal functor. \square

4.5 Fixed point of a linear functor

Given a parameterized linear functor, $F : \mathbb{Y} \times \mathbb{X} \rightarrow \mathbb{X}$, Proposition 4.4.1 suggests that one may be able to construct from the coinductive fixed point of the monoidal part of F , \overrightarrow{F} , and the inductive fixed point of the comonoidal part of F , \overleftarrow{F} , a linear functor. The next theorem shows that this does happen by exhibiting the linear strengths and proving they satisfy the required coherence conditions.

Theorem 4.5.1. *The fixed point of a linear functor is linear.*

Proof. In previous section, we proved \overrightarrow{F} is monoidal (and dually, \overleftarrow{F} is comonoidal). It remains to prove that (i) the linear strengths exist; (ii) they are natural and (iii) they satisfy several coherence conditions.

We know that a linear functor has four linear strengths, v_{\oplus}^R , v_{\oplus}^L , v_{\otimes}^R , and v_{\otimes}^L (See Section 2.13). In order to prove that linear strengths exist, first we will show that $v_{\oplus}^R : F(A) \otimes \overleftarrow{F}(B) \rightarrow \overleftarrow{F}(A \otimes B)$ exists. Then we will show that $v_{\otimes}^R : F(A \oplus B) \rightarrow \overleftarrow{F}(A) \oplus \overleftarrow{F}(B)$ exists. The others two linear strengths, v_{\oplus}^L and v_{\otimes}^L can be obtained by symmetries.

By using fixed point of (co)monoidal functor, the linear strength, v_{\oplus}^R will be $\overrightarrow{v}_{\oplus}^R : \overrightarrow{F}(A) \otimes \overleftarrow{F}(B) \rightarrow \overleftarrow{F}(A \otimes B)$. To check that $\overrightarrow{v}_{\oplus}^R$ exists and it is unique fold map, we have to use circular combinator $c[-]$. Given a circular combinator $c[-]$ for \overleftarrow{F} over D , there exists a unique \overleftarrow{f} such that the following diagram commutes.

$$\begin{array}{ccc}
 \overleftarrow{F}(\overleftarrow{F}) & \xrightarrow{\text{cons}} & \overleftarrow{F} \\
 \downarrow c[\overleftarrow{f}] & \searrow \overleftarrow{f} & \\
 D & &
 \end{array}$$

So \overleftarrow{f} exists if there is a combinator $c[_]$ (over \overline{F})

$$\frac{A \rightarrow D}{\overline{F}(A) \rightarrow D} c[_]$$

We get fixed points if and only if we have circular combinators. Given $h, k : \overleftarrow{F} \rightarrow D$. To show that $h = k$, it suffices to show that $\mathbf{cons} \ h = c[h]$ and $\mathbf{cons} \ k = c[k]$ where h and k are both unique. Then by uniqueness of \overleftarrow{f} , we have $h = \overleftarrow{f}$ and $k = \overleftarrow{f}$. Circular combinator is easily constructable by using proof box. To show that $\overrightarrow{v}_{\oplus}^R$ map exists, we have the following proof box:

$\forall X$	$\overrightarrow{F}(A) \otimes X \vdash_f \overleftarrow{F}(A \otimes B)$
$\frac{A \otimes B \vdash_1 A \otimes B \quad \overrightarrow{F}(A) \otimes X \vdash_f \overleftarrow{F}(A \otimes B)}{\overline{F}(A \otimes B, \overrightarrow{F}(A) \otimes X) \vdash_{\overline{F}(1,f)} \overline{F}(A \otimes B, \overleftarrow{F}(A \otimes B))}$	
$\frac{\overline{F}(A \otimes B, \overrightarrow{F}(A) \otimes X) \vdash_{\overline{F}(1,f)} \mathbf{cons} \ \overleftarrow{F}(A \otimes B)}{\overline{F}(A, \overrightarrow{F}(A)) \otimes \overline{F}(B, X) \vdash_{v_{\oplus}^R \ \overline{F}(1,f)} \mathbf{cons} \ \overleftarrow{F}(A \otimes B)}$	
$\overrightarrow{F}(A) \otimes \overline{F}(B, X) \vdash_{(\mathbf{dest} \otimes 1) \ v_{\oplus}^R \ \overline{F}(1,f)} \mathbf{cons} \ \overleftarrow{F}(A \otimes B)$	
$\overrightarrow{F}(A) \otimes \overleftarrow{F}(B) \vdash_{\overrightarrow{v}_{\oplus}^R} \overleftarrow{F}(A \otimes B)$	

So there exists $\overrightarrow{v}_{\oplus}^R$. It is the unique fold map such that $(1 \otimes \mathbf{cons}) \ \overrightarrow{v}_{\oplus}^R = c[\overrightarrow{v}_{\oplus}^R] = (\mathbf{dest} \otimes 1) \ v_{\oplus}^R \ \overline{F}(1, \overrightarrow{v}_{\oplus}^R) \ \mathbf{cons}$. As $\overrightarrow{v}_{\oplus}^R$ gives natural transformation, so we have to check the following diagram commutes.

$$\begin{array}{ccc} \overrightarrow{F}(A) \otimes \overleftarrow{F}(B) & \xrightarrow{\overrightarrow{v}_{\oplus}^R} & \overleftarrow{F}(A \otimes B) \\ \overrightarrow{F}(a) \otimes \overleftarrow{F}(b) \downarrow & & \downarrow \overleftarrow{F}(a \otimes b) \\ \overrightarrow{F}(A') \otimes \overleftarrow{F}(B') & \xrightarrow{\overrightarrow{v}_{\oplus}^R} & \overleftarrow{F}(A' \otimes B') \end{array}$$

To show that $\overrightarrow{v}_{\oplus}^R \ \overleftarrow{F}(a \otimes b) = (\overrightarrow{F}(a) \otimes \overleftarrow{F}(b)) \ \overrightarrow{v}_{\oplus}^R$, it suffices to show that they are both

equal to the fold map. That means it suffices to find a combinator $\mathbf{b}[-]$ such that

$$(1 \otimes \text{cons}) \overrightarrow{v}_{\oplus}^R \overleftarrow{F}(a \otimes b) = \mathbf{b}[\overrightarrow{v}_{\oplus}^R \overleftarrow{F}(a \otimes b)] \quad (4.1)$$

$$(1 \otimes \text{cons}) (\overrightarrow{F}(a) \otimes \overleftarrow{F}(b)) \overrightarrow{v}_{\oplus}^R = \mathbf{b}[(\overrightarrow{F}(a) \otimes \overleftarrow{F}(b)) \overrightarrow{v}_{\oplus}^R] \quad (4.2)$$

Validity of equation 4.1 is shown in Figure 4.6. In this figure, the upper part commutes because of the defining diagram of $\overrightarrow{v}_{\oplus}^R$ [as $\overrightarrow{v}_{\oplus}^R$ is unique such that $(1 \otimes \text{cons}) \overrightarrow{v}_{\oplus}^R = (\text{dest} \otimes 1) v_{\oplus}^R \overleftarrow{F}(1, \overrightarrow{v}_{\oplus}^R) \text{cons}$]. The lower part commutes because of the defining diagram of \overleftarrow{F} . Here, the combinator is $\mathbf{b}[\overrightarrow{v}_{\oplus}^R \overleftarrow{F}(a \otimes b)] = (\text{dest} \otimes 1) v_{\oplus}^R \overleftarrow{F}(1, \overrightarrow{v}_{\oplus}^R) \overleftarrow{F}(a \otimes b, \overleftarrow{F}(a \otimes b)) \text{cons}$. So we get from the Figure 4.6, $(1 \otimes \text{cons}) \overrightarrow{v}_{\oplus}^R \overleftarrow{F}(a \otimes b) = \mathbf{b}[\overrightarrow{v}_{\oplus}^R \overleftarrow{F}(a \otimes b)] = (\text{dest} \otimes 1) v_{\oplus}^R \overleftarrow{F}(1, \overrightarrow{v}_{\oplus}^R) \overleftarrow{F}(a \otimes b, \overleftarrow{F}(a \otimes b)) \text{cons}$.

The diagram for equation 4.2 is shown in Figure 4.7. In this figure, there are six cells where (2) and (5) commute because v_{\oplus}^R gives natural transformation, (1) commutes by the defining diagram of \overleftarrow{F} , (6) commutes because $\overrightarrow{v}_{\oplus}^R$ is unique, (4) commutes because of tensor (\otimes) functor and validity of cell (3) is shown in Figure 4.8 where, (1) and (2) commutes because of the tensor (\otimes) functor and (3) commutes because of the defining diagram of \overleftarrow{F} . So we get, $(1 \otimes \text{cons}) (\overrightarrow{F}(a) \otimes \overleftarrow{F}(b)) \overrightarrow{v}_{\oplus}^R = \mathbf{b}[(\overrightarrow{F}(a) \otimes \overleftarrow{F}(b)) \overrightarrow{v}_{\oplus}^R] = (\text{dest} \otimes 1) v_{\oplus}^R \overleftarrow{F}(a \otimes b, \overrightarrow{F}(a) \otimes \overleftarrow{F}(b)) \overleftarrow{F}(1, \overrightarrow{v}_{\oplus}^R) \text{cons}$.

We know that linear strengths satisfy a large number of coherence conditions. In order to prove this theorem first we will check the coherence condition, $(m_{\otimes} \otimes 1) v_{\oplus}^R \overleftarrow{F}(a_{\otimes}) = a_{\otimes} (1 \otimes v_{\oplus}^R) v_{\oplus}^R$ which links m_{\otimes} , v_{\oplus}^R , and a_{\otimes} . The other forms of this coherence condition are obtained by symmetries. Then we will check the coherence condition, $(v_{\oplus}^R \otimes 1) v_{\oplus}^L \overleftarrow{F}(a_{\otimes}) = a_{\otimes} (1 \otimes v_{\oplus}^L) v_{\oplus}^R$, which creates a link between a_{\otimes} , v_{\oplus}^L and v_{\oplus}^R . The symmetries generate all the other forms of this coherence condition. Finally, we will prove that the coherence condition, $(v_{\otimes}^R \otimes 1) d_{\otimes}^{\oplus} (1 \oplus m_{\otimes}) = m_{\otimes} F(d_{\otimes}^{\oplus}) v_{\otimes}^R$ holds which links m_{\otimes} , d_{\otimes}^{\oplus} , and v_{\otimes}^R . All the other forms of this coherence condition are generated by symmetries.

$$\begin{array}{ccc}
\overline{F}(A) \otimes \overline{F}(B, \overline{F}(B)) & \xrightarrow{1 \otimes \text{cons}} & \overline{F}(A) \otimes \overline{F}(B) \\
\downarrow \text{dest} \otimes 1 & & \downarrow \overline{v}_{\oplus}^R \\
F(A, \overline{F}(A)) \otimes \overline{F}(B, \overline{F}(B)) & & \overline{F}(A \otimes B) \\
\downarrow v_{\oplus}^R & & \downarrow \overline{F}(a \otimes b) \\
\overline{F}(A \otimes B, \overline{F}(A) \otimes \overline{F}(B)) & \xrightarrow{\text{cons}} & \overline{F}(A \otimes B) \\
\downarrow \overline{F}(1, \overline{v}_{\oplus}^R) & & \downarrow \overline{F}(a \otimes b) \\
\overline{F}(A \otimes B, \overline{F}(A \otimes B)) & & \overline{F}(A \otimes B) \\
\downarrow \overline{F}(a \otimes b, \overline{F}(a \otimes b)) & & \downarrow \overline{F}(a \otimes b) \\
\overline{F}(A' \otimes B', \overline{F}(A' \otimes B')) & \xrightarrow{\text{cons}} & \overline{F}(A' \otimes B')
\end{array}$$

Figure 4.6: Validity of equation 4.1

Now we will prove that the coherence condition $(m_{\otimes} \otimes 1) v_{\oplus}^R \overline{F}(a_{\otimes}) = a_{\otimes} (1 \otimes v_{\oplus}^R) v_{\oplus}^R$ holds. If we use the fixed point of (co)monoidal functor, then the coherence condition will be

$$\begin{array}{ccc}
(\overline{m} \otimes 1) \overline{v}_{\oplus}^R \overleftarrow{F}(a_{\otimes}) & = & a_{\otimes} (1 \otimes \overline{v}_{\oplus}^R) \overline{v}_{\oplus}^R. \\
\overline{F}(A) \otimes \overline{F}(B) \otimes \overleftarrow{F}(C) & \xrightarrow{a_{\otimes}} & \overline{F}(A) \otimes (\overline{F}(B) \otimes \overleftarrow{F}(C)) \\
\downarrow \overline{m} \otimes 1 & & \downarrow 1 \otimes \overline{v}_{\oplus}^R \\
\overline{F}(A \otimes B) \otimes \overleftarrow{F}(C) & & \overline{F}(A) \otimes \overleftarrow{F}(B \otimes C) \\
\downarrow \overline{v}_{\oplus}^R & & \downarrow \overline{v}_{\oplus}^R \\
\overleftarrow{F}((A \otimes B) \otimes C) & \xrightarrow{\overleftarrow{F}(a_{\otimes})} & \overleftarrow{F}(A \otimes (B \otimes C))
\end{array}$$

We have to show that the above diagram commutes. It suffices to show that they are both equal to the fold map. This means it suffices to find a combinator $u[-]$ such that

$$((1 \otimes 1) \otimes \text{cons}) a_{\otimes} (1 \otimes \overline{v}_{\oplus}^R) \overline{v}_{\oplus}^R = u[a_{\otimes} (1 \otimes \overline{v}_{\oplus}^R) \overline{v}_{\oplus}^R] \quad (4.3)$$

$$((1 \otimes 1) \otimes \text{cons}) (\overline{m} \otimes 1) \overline{v}_{\oplus}^R \overleftarrow{F}(a_{\otimes}) = u[(\overline{m} \otimes 1) \overline{v}_{\oplus}^R \overleftarrow{F}(a_{\otimes})] \quad (4.4)$$

$$\begin{array}{ccccc}
\overline{F}(A) \otimes \overline{F}(B, \overline{F}(B)) & \xrightarrow{1 \otimes \overline{F}(1, \overline{F}(b))} & \overline{F}(A) \otimes \overline{F}(B, \overline{F}(B')) & \xrightarrow{1 \otimes \overline{F}(b, 1)} & \overline{F}(A) \otimes \overline{F}(B', \overline{F}(B')) & \xrightarrow{\overline{F}(a) \otimes 1} & \overline{F}(A') \otimes \overline{F}(B', \overline{F}(B')) \\
\downarrow \text{dest} \otimes 1 & & \downarrow \text{dest} \otimes 1 & & \downarrow \text{dest} \otimes 1 & & \downarrow \text{dest} \otimes 1 \\
F(A, \overline{F}(A)) \otimes \overline{F}(B, \overline{F}(B)) & & F(A, \overline{F}(A)) \otimes \overline{F}(B, \overline{F}(B')) & & F(A, \overline{F}(A)) \otimes \overline{F}(B', \overline{F}(B')) & & F(A', \overline{F}(A')) \otimes \overline{F}(B', \overline{F}(B')) \\
\downarrow 1 \otimes \overline{F}(1, \overline{F}(b)) & & \downarrow 1 \otimes \overline{F}(1, \overline{F}(b)) & & \downarrow 1 \otimes \overline{F}(1, \overline{F}(b)) & & \downarrow 1 \otimes \overline{F}(1, \overline{F}(b)) \\
F(A, \overline{F}(A)) \otimes \overline{F}(B, \overline{F}(B)) & & F(A, \overline{F}(A)) \otimes \overline{F}(B, \overline{F}(B')) & & F(A, \overline{F}(A)) \otimes \overline{F}(B', \overline{F}(B')) & & F(A, \overline{F}(A)) \otimes \overline{F}(B', \overline{F}(B')) \\
\downarrow 1 \otimes \overline{F}(b, 1) & & \downarrow 1 \otimes \overline{F}(b, 1) & & \downarrow 1 \otimes \overline{F}(b, 1) & & \downarrow 1 \otimes \overline{F}(b, 1) \\
F(A, \overline{F}(A)) \otimes \overline{F}(B', \overline{F}(B')) & \xrightarrow{F(a, 1) \otimes 1} & F(A', \overline{F}(A)) \otimes \overline{F}(B', \overline{F}(B')) & \xrightarrow{F(1, \overline{F}(a)) \otimes 1} & F(A', \overline{F}(A')) \otimes \overline{F}(B', \overline{F}(B')) & & F(A', \overline{F}(A')) \otimes \overline{F}(B', \overline{F}(B'))
\end{array}$$

Figure 4.8: Validity of diagram (3) from Figure 4.7

Now we have to show that the coherence condition, $(v_{\oplus}^R \otimes 1) v_{\oplus}^L \overline{F}(a_{\otimes}) = a_{\otimes} (1 \otimes v_{\oplus}^L) v_{\oplus}^R$ holds. Using the fixed point of (co)monoidal functor, we can write this equation as:

$$(\overline{v}_{\oplus}^R \otimes 1) \overline{v}_{\oplus}^L \overline{F}(a_{\otimes}) = a_{\otimes} (1 \otimes \overline{v}_{\oplus}^L) \overline{v}_{\oplus}^R$$

$$\begin{array}{ccc}
(\overline{F}(A) \otimes \overline{F}(B)) \otimes \overline{F}(C) & \xrightarrow{a_{\otimes}} & \overline{F}(A) \otimes (\overline{F}(B) \otimes \overline{F}(C)) \\
\downarrow \overline{v}_{\oplus}^R \otimes 1 & & \downarrow 1 \otimes \overline{v}_{\oplus}^L \\
\overline{F}(A \otimes B) \otimes \overline{F}(C) & & \overline{F}(A) \otimes \overline{F}(B \otimes C) \\
\downarrow \overline{v}_{\oplus}^L & & \downarrow \overline{v}_{\oplus}^R \\
\overline{F}((A \otimes B) \otimes C) & \xrightarrow{\overline{F}(a_{\otimes})} & \overline{F}(A \otimes (B \otimes C))
\end{array}$$

We have to show that the above diagram commutes. It suffices to show that they are both equal to the fold map. This means it suffices to find a combinator $\mathbf{v}[_]$ such that

$$((1 \otimes \mathbf{cons}) \otimes 1) a_{\otimes} (1 \otimes \overline{v}_{\oplus}^L) \overline{v}_{\oplus}^R = \mathbf{v}[a_{\otimes} (1 \otimes \overline{v}_{\oplus}^L) \overline{v}_{\oplus}^R] \quad (4.5)$$

$$((1 \otimes \mathbf{cons}) \otimes 1) (\overline{v}_{\oplus}^R \otimes 1) \overline{v}_{\oplus}^L \overline{F}(a_{\otimes}) = \mathbf{v}[(\overline{v}_{\oplus}^R \otimes 1) \overline{v}_{\oplus}^L \overline{F}(a_{\otimes})] \quad (4.6)$$

The diagram for equation 4.5 is shown in Figure 4.11. In this figure, (1) and (2) commute by the naturality of a_{\otimes} , (5) commutes by the naturality of v_{\oplus}^L , (6) commutes because of tensor (\otimes) functor, (3) commutes because \overline{v}_{\oplus}^L is unique, (8) commutes because \overline{v}_{\oplus}^R is unique, (4)

commutes from the definition of linear functor and (7) commutes because v_{\oplus}^R gives natural transformaton.

The diagram for equation 4.6 is shown in Figure 4.12 where (1) and (4) commute because of tensor (\otimes) functor, (2) commutes because $\overrightarrow{v}_{\oplus}^R$ is unique, (3) commutes by the naturality of v_{\oplus}^R , (5) commutes because $\overrightarrow{v}_{\oplus}^L$ is unique, (6) commutes because v_{\oplus}^L is natural transformaton and (7) commutes by the defining diagram of \overleftarrow{F} .

Now we will show that the coherence condition, $(v_{\otimes}^R \otimes 1) d_{\otimes}^{\oplus} (1 \oplus m_{\otimes}) = m_{\otimes} F(d_{\otimes}^{\oplus}) v_{\otimes}^R$ holds. Before going to the proof of this coherence condition, first we have to check that the linear strength, $v_{\otimes}^R : F(A \oplus B) \rightarrow \overleftarrow{F}(A) \oplus F(B)$ exists. If we use fixed point of a (co) monoidal functor then we can write $\overrightarrow{v}_{\otimes}^R : \overrightarrow{F}(A \oplus B) \rightarrow \overleftarrow{F}(A) \oplus \overrightarrow{F}(B)$. To check that $\overrightarrow{v}_{\otimes}^R$ map exists and it is the unique **unfold** map, we have to use circular combinator $d[-]$. Given a circular combinator $d[-]$ for F over D , there exists a unique \overrightarrow{f} such that the following diagram commutes.

$$\begin{array}{ccc}
 D & \xrightarrow{\overrightarrow{f}} & \overrightarrow{F} \\
 \downarrow d[\overrightarrow{f}] & \searrow \text{dest} & \\
 F(\overrightarrow{F}) & &
 \end{array}$$

So \overrightarrow{f} exists if there is a combinator $d[-]$ (over F)

$$\frac{D \rightarrow A}{D \rightarrow F(A)} d[-]$$

We get fixed points if and only if we have circular combinators. Given $h, k : D \rightarrow \overrightarrow{F}$, we have to show that $h = k$. It suffices to show that $h \text{ dest} = d[h]$ and $k \text{ dest} = d[k]$ where h and k are both unique. Then by uniqueness of \overrightarrow{f} , we have $h = \overrightarrow{f}$ and $k = \overrightarrow{f}$.

In order to show that $\overrightarrow{v}_{\otimes}^R$ exists, we have the following proof box:

$\forall X$	$\vec{F}(A \oplus B) \vdash_f \overleftarrow{F}(A) \oplus X$
$\frac{A \oplus B \vdash_1 A \oplus B \quad \vec{F}(A \oplus B) \vdash_f \overleftarrow{F}(A) \oplus X}{F(A \oplus B, \vec{F}(A \oplus B)) \vdash_{F(1,f)} F(A \oplus B, \overleftarrow{F}(A) \oplus X)}$ $\frac{\vec{F}(A \oplus B) \vdash_{\text{dest } F(1,f)} F(A \oplus B, \overleftarrow{F}(A) \oplus X)}{\vec{F}(A \oplus B) \vdash_{\text{dest } F(1,f) v_{\otimes}^R} \overleftarrow{F}(A, \overleftarrow{F}(A)) \oplus F(B, X)}$ $\frac{\vec{F}(A \oplus B) \vdash_{\text{dest } F(1,f) v_{\otimes}^R} \overleftarrow{F}(A, \overleftarrow{F}(A)) \oplus F(B, X)}{\vec{F}(A \oplus B) \vdash_{\text{dest } F(1,f) v_{\otimes}^R (\text{cons} \oplus 1)} \overleftarrow{F}(A) \oplus F(B, X)}$	
$\vec{F}(A \oplus B) \vdash_{\vec{v}_{\otimes}^R} \overleftarrow{F}(A) \oplus \vec{F}(B)$	

So there exists \vec{v}_{\otimes}^R . It is unique **unfold** map such that

$$\vec{v}_{\otimes}^R (1 \oplus \text{dest}) = \mathbf{d}[\vec{v}_{\otimes}^R] = \text{dest } F(1, \vec{v}_{\otimes}^R) v_{\otimes}^R (\text{cons} \oplus 1)$$

Now we can check the coherence condition, $(v_{\otimes}^R \otimes 1) d_{\otimes}^{\oplus} (1 \oplus m_{\otimes}) = m_{\otimes} F(d_{\otimes}^{\oplus}) v_{\otimes}^R$. Using the fixed point of a (co)monoidal functor, we can write $(\vec{v}_{\otimes}^R \otimes 1) d_{\otimes}^{\oplus} (1 \oplus \vec{m}) = \vec{m} \vec{F}(d_{\otimes}^{\oplus}) \vec{v}_{\otimes}^R$.

$$\begin{array}{ccc}
\vec{F}(A \oplus B) \otimes \vec{F}(C) & \xrightarrow{\vec{v}_{\otimes}^R \otimes 1} & (\overleftarrow{F}(A) \oplus \overleftarrow{F}(B)) \otimes \vec{F}(C) \\
\downarrow \vec{m} & & \downarrow d_{\otimes}^{\oplus} \\
\vec{F}((A \oplus B) \otimes C) & & \overleftarrow{F}(A) \oplus (\overleftarrow{F}(B) \otimes \vec{F}(C)) \\
\downarrow \vec{F}(d_{\otimes}^{\oplus}) & & \downarrow 1 \oplus \vec{m} \\
\vec{F}(A \oplus (B \otimes C)) & \xrightarrow{\vec{v}_{\otimes}^R} & \overleftarrow{F}(A) \oplus \vec{F}(B \otimes C)
\end{array}$$

So we have to show that the above diagram commutes. It suffices to show that they both equal to **unfold** map this means it suffices to find a combinator $\mathbf{x}[-]$ such that

$$(\vec{v}_{\otimes}^R \otimes 1) d_{\otimes}^{\oplus} (1 \oplus \vec{m}) (1 \oplus \text{dest}) = \mathbf{x}[(\vec{v}_{\otimes}^R \otimes 1) d_{\otimes}^{\oplus} (1 \oplus \vec{m})] \quad (4.7)$$

$$\vec{m} \vec{F}(d_{\otimes}^{\oplus}) \vec{v}_{\otimes}^R (1 \oplus \text{dest}) = \mathbf{x}[\vec{m} \vec{F}(d_{\otimes}^{\oplus}) \vec{v}_{\otimes}^R] \quad (4.8)$$

The diagram for equation 4.7 is shown in Figure 4.13. In this figure, (1) and (3) commute because of tensor (\otimes) functor, (2) commutes because \vec{v}_{\otimes}^R is unique, (4) commutes by the

naturality of m_{\otimes} , (5) commutes by the naturality of d_{\otimes}^{\oplus} , (7) commutes because of the defining diagram of \vec{m} and validity of diagram (6) is shown in Figure 4.14. In this Figure 4.14, (1) and (8) commute by the naturality of v_{\otimes}^R , (2) commutes because of tensor (\otimes) functor, (3) and (5) commute by the naturality for d_{\otimes}^{\oplus} , (4) commutes from the definition of linear functor, (6) commutes because of the naturality of m_{\otimes} and (7) commutes by par (\oplus) functor. Validity of equation 4.8 is shown in Figure 4.15. Here (1) commutes by the defining diagram of \vec{m} , (2) commutes by the defining diagram of \vec{F} and (3) commutes because \vec{v}_{\otimes}^R is unique. So if a linear functor has a linear fixed point then it is linear.

$$\begin{array}{c}
\begin{array}{ccc}
(\vec{F}(A) \otimes \vec{F}(B)) \otimes \vec{F}(C), \vec{F}(C) & \xrightarrow{(1 \otimes 1) \otimes \text{cons}} & (\vec{F}(A) \otimes \vec{F}(B)) \otimes \vec{F}(C) \\
\downarrow (\text{dest} \otimes \text{dest}) \otimes 1 & \searrow^{a \otimes} & \downarrow^{a \otimes} \\
(F(A, \vec{F}(A)) \otimes F(B, \vec{F}(B))) \otimes \vec{F}(C), \vec{F}(C) & \xrightarrow{a \otimes} & \vec{F}(A) \otimes (\vec{F}(B) \otimes \vec{F}(C)), \vec{F}(C) \\
\downarrow m \otimes 1 & & \downarrow 1 \otimes (\text{dest} \otimes 1) \\
F(A \otimes B, \vec{F}(A) \otimes \vec{F}(B)) \otimes \vec{F}(C), \vec{F}(C) & \xrightarrow{a \otimes} & F(A, \vec{F}(A)) \otimes (F(B, \vec{F}(B)) \otimes \vec{F}(C), \vec{F}(C)) \\
\downarrow v \oplus^R & & \downarrow 1 \otimes v \oplus^R \\
\vec{F}(((A \otimes B) \otimes C), ((\vec{F}(A) \otimes \vec{F}(B)) \otimes \vec{F}(C))) & \xrightarrow{a \otimes} & F(A, \vec{F}(A)) \otimes \vec{F}(B \otimes C, \vec{F}(B) \otimes \vec{F}(C)) \\
\downarrow \vec{F}(a \otimes, a \otimes) & & \downarrow v \oplus^R \\
\vec{F}((A \otimes (B \otimes C)), (\vec{F}(A) \otimes (\vec{F}(B) \otimes \vec{F}(C)))) & \xrightarrow{\vec{F}(1, 1 \otimes v \oplus^R)} & \vec{F}((A \otimes (B \otimes C)), (\vec{F}(A) \otimes \vec{F}(B \otimes C))) \\
\downarrow \vec{F}(1, v \oplus^R) & & \downarrow v \oplus^R \\
\vec{F}((A \otimes (B \otimes C)), \vec{F}(A \otimes (B \otimes C))) & \xrightarrow{\vec{F}(1, v \oplus^R)} & \vec{F}((A \otimes (B \otimes C)), \vec{F}(A \otimes (B \otimes C))) \\
\downarrow \vec{F}(1, v \oplus^R) & & \downarrow v \oplus^R \\
\vec{F}(A \otimes (B \otimes C)) & \xrightarrow{\text{cons}} & \vec{F}(A \otimes (B \otimes C))
\end{array}
\end{array}$$

The diagram illustrates the validity of equation 4.3 through a series of commutative steps labeled (1) through (8). The nodes represent tensor products of objects and their images under various functors and natural transformations. The transformations include multiplication by 1, application of the functor \vec{F} , and natural transformations like $a \otimes$, $v \oplus^R$, and $\vec{F}(a \otimes, a \otimes)$. The final result is the equality of the two paths from the top-left node to the bottom-right node.

Figure 4.9: Validity of equation 4.3

$$\begin{array}{ccc}
(\bar{F}(A) \otimes \bar{F}(B)) \otimes \bar{F}(C), \bar{F}(C)) & \xrightarrow{(1 \otimes 1) \otimes \text{cons}} & (\bar{F}(A) \otimes \bar{F}(B)) \otimes \bar{F}(C) \\
\downarrow (\text{dest} \otimes \text{dest}) \otimes 1 & \searrow \bar{m} \otimes 1 & \downarrow \bar{m} \otimes 1 \\
(F(A, \bar{F}(A)) \otimes F(B, \bar{F}(B))) \otimes \bar{F}(C), \bar{F}(C)) & \xrightarrow{(1) \otimes \text{cons}} & \bar{F}(A \otimes B) \otimes \bar{F}(C) \\
\downarrow m \otimes 1 & \downarrow \text{dest} \otimes 1 & \downarrow \bar{m} \otimes 1 \\
F(A \otimes B, \bar{F}(A) \otimes \bar{F}(B)) \otimes \bar{F}(C), \bar{F}(C) & \xrightarrow{F(1, \bar{m}) \otimes \bar{F}(1, 1)} & F(A \otimes B, \bar{F}(A \otimes B)) \otimes \bar{F}(C), \bar{F}(C) \\
\downarrow v_{\oplus}^R & \swarrow v_{\oplus}^R & \downarrow \bar{v}_{\oplus}^R \\
\bar{F}(((A \otimes B) \otimes C), ((\bar{F}(A) \otimes \bar{F}(B)) \otimes \bar{F}(C))) & \xrightarrow{(3)} & \bar{F}(A \otimes B) \otimes \bar{F}(C) \\
\downarrow \bar{F}(1, \bar{m} \otimes 1) & \swarrow v_{\oplus}^R & \downarrow \bar{v}_{\oplus}^R \\
\bar{F}(((A \otimes B) \otimes C), (\bar{F}(A \otimes B) \otimes \bar{F}(C))) & \xrightarrow{(4)} & \bar{F}(A \otimes B) \otimes \bar{F}(C) \\
\downarrow \bar{F}(1, \bar{v}_{\oplus}^R) & \swarrow v_{\oplus}^R & \downarrow \bar{v}_{\oplus}^R \\
\bar{F}(((A \otimes B) \otimes C), \bar{F}((A \otimes B) \otimes C)) & \xrightarrow{\text{cons}} & \bar{F}((A \otimes B) \otimes C) \\
\downarrow \bar{F}(a_{\otimes}, \bar{F}(a_{\otimes})) & \swarrow v_{\oplus}^R & \downarrow \bar{F}(a_{\otimes}) \\
\bar{F}((A \otimes (B \otimes C)), \bar{F}(A \otimes (B \otimes C))) & \xrightarrow{\text{cons}} & \bar{F}(A \otimes (B \otimes C))
\end{array}$$

Figure 4.10: Validity of equation 4.4

$$\begin{array}{ccc}
(\overline{F}(A) \otimes \overline{F}(B, \overline{F}(B))) \otimes \overline{F}(C) & \xrightarrow{(1 \otimes \text{cons}) \otimes 1} & (\overline{F}(A) \otimes \overline{F}(B)) \otimes \overline{F}(C) \\
\downarrow (\text{dest} \otimes 1) \otimes \text{dest} \quad (1) & \searrow (\text{dest} \otimes 1) \otimes 1 & \downarrow \overline{v} \otimes 1 \\
(F(A, \overline{F}(A)) \otimes \overline{F}(B, \overline{F}(B))) \otimes F(C, \overline{F}(C)) & \xleftarrow{(1 \otimes 1) \otimes \text{dest}} (F(A, \overline{F}(A)) \otimes \overline{F}(B, \overline{F}(B))) \otimes \overline{F}(C) \xrightarrow{v \otimes 1} \overline{F}(A \otimes B, \overline{F}(A) \otimes \overline{F}(B)) \otimes \overline{F}(C) \xrightarrow{\overline{F}(1, \overline{v} \otimes 1)} \overline{F}(A \otimes B, \overline{F}(A \otimes B)) \otimes \overline{F}(C) \xrightarrow{\text{cons} \otimes 1} \overline{F}(A \otimes B) \otimes \overline{F}(C) & \downarrow \overline{v} \otimes 1 \\
\downarrow v \otimes 1 & \swarrow 1 \otimes \text{dest} \quad (3) & \downarrow 1 \otimes \text{dest} \\
\overline{F}(A \otimes B, \overline{F}(A) \otimes \overline{F}(B)) \otimes F(C, \overline{F}(C)) & \xrightarrow{\overline{F}(1, \overline{v} \otimes 1)} \overline{F}(A \otimes B, \overline{F}(A \otimes B)) \otimes F(C, \overline{F}(C)) & \downarrow 1 \otimes \text{dest} \\
\downarrow v \otimes 1 & \swarrow v \otimes 1 & \downarrow \overline{v} \otimes 1 \\
\overline{F}(((A \otimes B) \otimes C), ((\overline{F}(A) \otimes \overline{F}(B)) \otimes \overline{F}(C))) & \xrightarrow{\overline{F}(1, \overline{v} \otimes 1)} \overline{F}(((A \otimes B) \otimes C), (\overline{F}(A \otimes B) \otimes \overline{F}(C))) & \downarrow \overline{v} \otimes 1 \\
\downarrow \overline{F}(1, \overline{v} \otimes 1) & \swarrow \overline{F}(1, \overline{v} \otimes 1) & \downarrow \overline{v} \otimes 1 \\
\overline{F}(((A \otimes B) \otimes C), (\overline{F}(A \otimes B) \otimes \overline{F}(C))) & \xrightarrow{\overline{F}(1, \overline{v} \otimes 1)} \overline{F}(((A \otimes B) \otimes C), (\overline{F}(A \otimes B) \otimes \overline{F}(C))) & \downarrow \overline{v} \otimes 1 \\
\downarrow \overline{F}(1, \overline{v} \otimes 1) & \swarrow \overline{F}(1, \overline{v} \otimes 1) & \downarrow \overline{v} \otimes 1 \\
\overline{F}(((A \otimes B) \otimes C), \overline{F}((A \otimes B) \otimes C)) & \xrightarrow{\text{cons}} \overline{F}((A \otimes B) \otimes C) & \downarrow \overline{v} \otimes 1 \\
\downarrow \overline{F}(a \otimes, \overline{F}(a \otimes)) & \swarrow \overline{F}(a \otimes, \overline{F}(a \otimes)) & \downarrow \overline{v} \otimes 1 \\
\overline{F}((A \otimes (B \otimes C)), \overline{F}(A \otimes (B \otimes C))) & \xrightarrow{\text{cons}} \overline{F}(A \otimes (B \otimes C)) & \downarrow \overline{v} \otimes 1 \\
& & \downarrow \overline{v} \otimes 1 \\
& & \overline{F}(A \otimes (B \otimes C))
\end{array}$$

Figure 4.12: Validity of equation 4.6

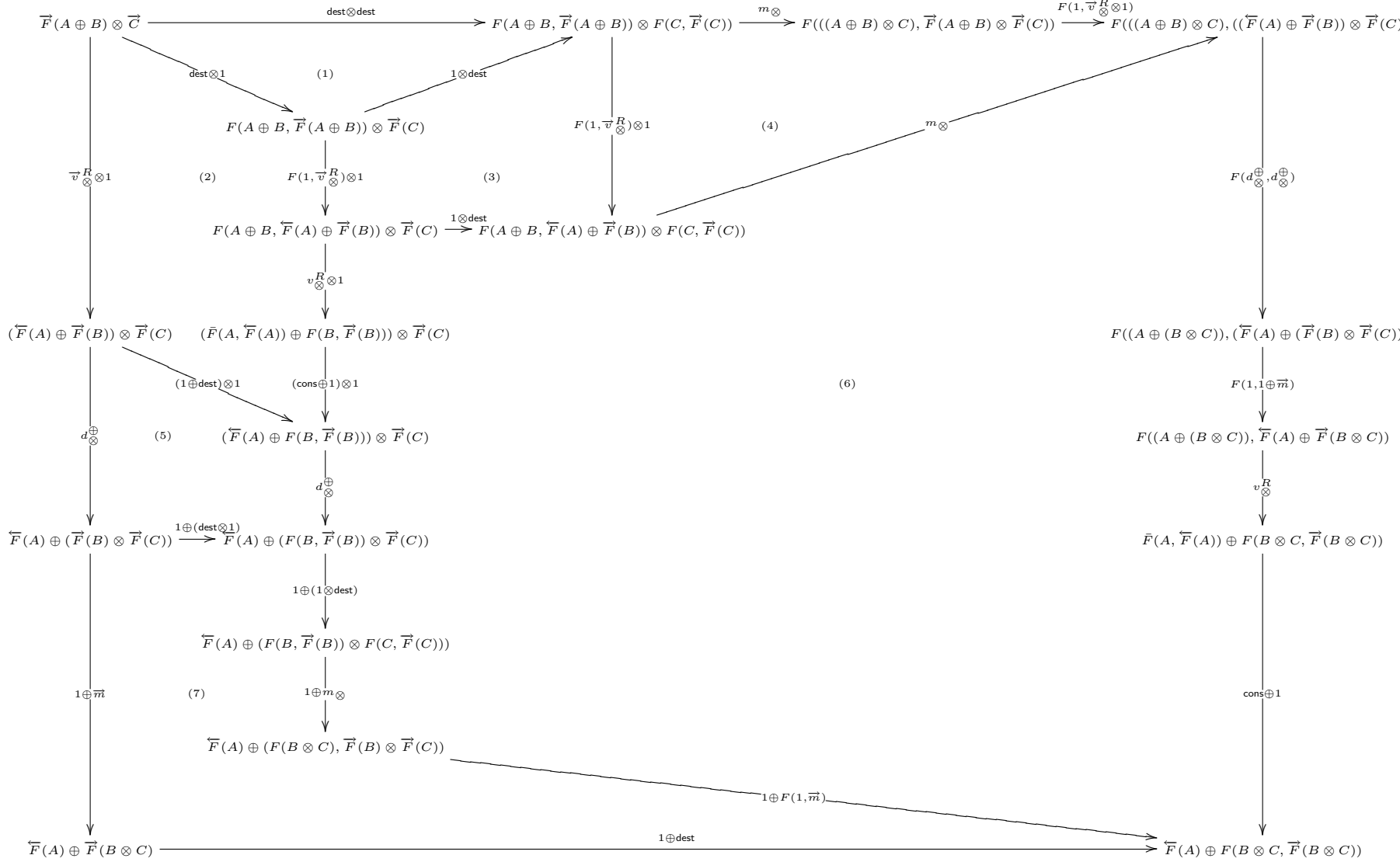

Figure 4.13: Validity of equation 4.7

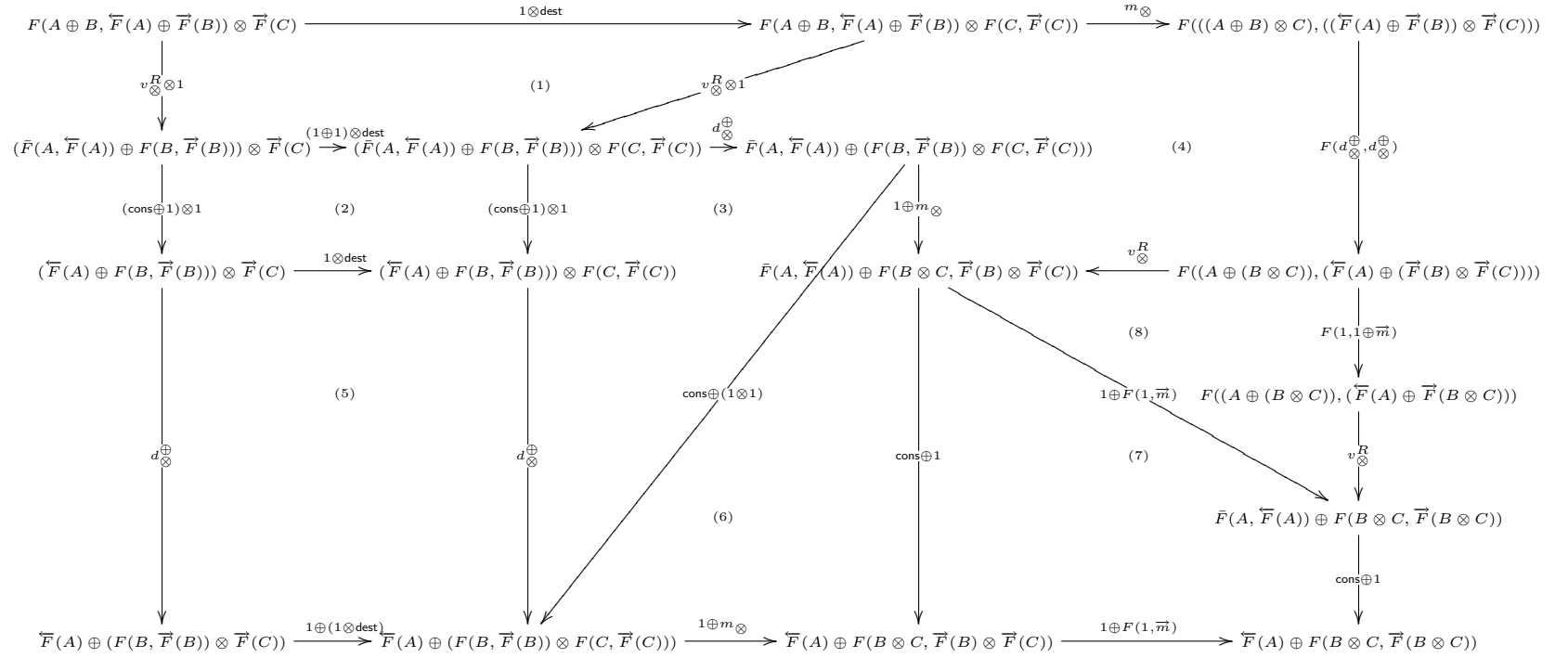

Figure 4.14: Validity of diagram (6) from Figure 4.8

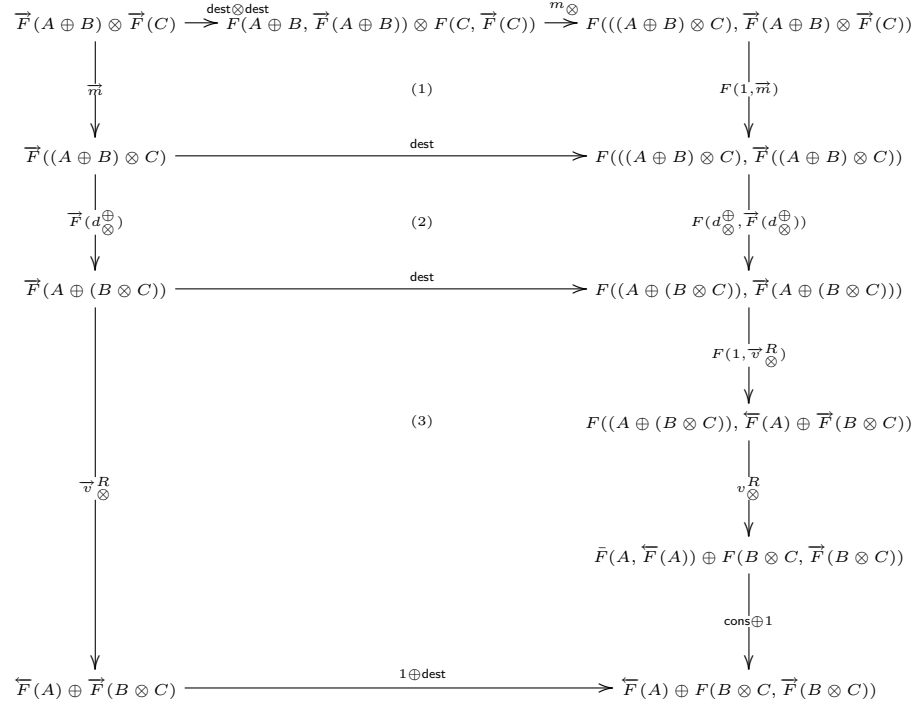

Figure 4.15: Validity of equation 4.8

□

Thus, the fixed point of a linear functor satisfies all the conditions to be a linear functor. The inductive and coinductive datatypes are the fixed points of linear functors that give protocols in concurrent communication and Theorem 4.5.1 proves that the protocols which are built on linear functors form a linear functor pair.

Chapter 5

Conclusion and Future Work

This thesis proposed the categorical semantics of protocols as inductive and coinductive data in the message passing world. We began with the definition of linear actegories, proposed by Cockett and Pastro, which provides a categorical semantics for message passing. A linear actegory consists of a linearly distributive category with a monoidal category that acts on it both covariantly and contravariantly. In this thesis, first we proved that the contravariant action of a linear actegory gives a monoidal functor. Dually, the covariant action gives rise to a comonoidal functor. Then we proved that these two actions of a linear actegory yield the structure of a linear functor. In order to prove this, we used the circuit diagrams representation of the maps of a linear actegory.

Next we discussed fixed points and the significance of the circular definition to this work. We then proved that the fixed point of a monoidal functor is monoidal, and dually the fixed point of a comonoidal functor is comonoidal. Finally, it was shown that the fixed point of a linear functor is itself a linear functor. This means protocols which are generated by linear functors form a linear functor pair.

Future Work This thesis provided the technical details for the formulation of special protocols generated by linear functors. However, there are general protocols which are not built on linear functors. In this thesis, we did not explore the properties of general protocols which is left to future work. From the programming language perspective, it will be interesting to have an implementation of the view of concurrent processes and their protocols suggested by this work.

Bibliography

- [1] Samson Abramsky and Radha Jagadeesan. Games and full completeness for multiplicative linear logic. *Journal of Symbolic Logic*, 59:543–574, 1994.
- [2] Samson Abramsky, Paul-André Melliès, and Equipe De Logique Mathématique. Concurrent games and full completeness, 1998.
- [3] M. Barr and C. Wells. *Category Theory for Computing Science*. Centre de Recherches Mathématiques, third edition, 1999.
- [4] Michael Barr. *-autonomous categories, 1979.
- [5] Michael Barr. *-autonomous categories, revisited. *Journal of Pure and Applied Algebra*, 111:1–20, 1996.
- [6] R. F. Blute, J.R.B. Cockett, R.A.G. Seely, and T. H. Trimble. Natural deduction and coherence for weakly distributive categories. *Journal of Pure and Applied Algebra*, 113:229–296, 1991.
- [7] J. R. B. Cockett and C. A. Pastro. A language for multiplicative-additive linear logic. *Electron. Notes Theor. Comput. Sci.*, 122:23–65, 2005.
- [8] J. R. B. Cockett and Craig Pastro. The logic of message-passing. *Sci. Comput. Program.*, 74:498–533, 2009.
- [9] J. R. B. Cockett and R. A. G. Seely. Finite sum - product logic. *Theory Appl. Categ.*, 8:2001, 2001.
- [10] J. R. B. Cockett and Dwight Spencer. Strong categorical datatypes I, 1991.

- [11] J. Robin B. Cockett and Dwight Spencer. Strong categorical datatypes II: a term logic for categorical programming. *Theor. Comput. Sci.*, 139:69–113, 1995.
- [12] J.R.B. Cockett. *Category theory for computer science*, 2009.
- [13] J.R.B. Cockett. *Notes on operational semantics of processes*. 2009.
- [14] J.R.B. Cockett and R.A.G. Seely. Linearly distributive functors. *J. Pure Appl. Algebra*, 143:155–203, 1997.
- [15] Vincent Danos and Laurent Regnier. The structure of multiplicatives. *Archive for Mathematical Logic*, 28:181–203, 1989.
- [16] Jean-Yves Girard. Linear logic. *Theor. Comput. Sci.*, 50(1):1–102, Jan 1987.
- [17] Marco Giunti and Vasco T. Vasconcelos. A linear account of session types in the pi calculus. In *Proceedings of the 21st international conference on Concurrency theory*, pages 432–446. Springer-Verlag, 2010.
- [18] Kohei Honda, Vasco T. Vasconcelos, and Makoto Kubo. Language primitives and type discipline for structured communication-based programming. In *Proceedings of the 7th European Symposium on Programming: Programming Languages and Systems*, pages 122–138. Springer-Verlag, 1998.
- [19] Bart Jacobs and Jan Rutten. A tutorial on (co)algebras and (co)induction. *EATCS Bulletin*, 62:62–222, 1997.
- [20] A. Joyal. Free bicomplete categories, 1995.
- [21] Andre Joyal and Ross Street. The geometry of tensor calculus I. *Advances in Mathematics*, 88:55–112, 1991.

- [22] R. Milner. *A Calculus of Communicating Systems*. Springer-Verlag New York, Inc., 1982.
- [23] Alberto Pardo. A calculational approach to strong datatypes, 1996.
- [24] C.A. Pasto. $\sum \prod$ -polycategories, additive linear logic, and process semantics. Master's thesis, University of Calgary, 2004.
- [25] Matthew Sackman and Susan Eisenbach, Jul-2008. Session Types in Haskell: Updating Message Passing for the 21st Century.
- [26] Luigi Santocanale. Parity functors and μ -bicomplete categories. In *Fixed Points in Computer Science*, 2001.
- [27] Luigi Santocanale. Free μ -lattices. *Journal of Pure and Applied Algebra*, 168(2-3):227–264, 2002.
- [28] Cockett Seely, J. R. B. Cockett, and R. A. G. Seely. Weakly distributive categories. In *Journal of Pure and Applied Algebra*, pages 45–65. University Press, 1991.
- [29] Varmo Vene. *Categorical Programming with Inductive and Coinductive Types*. PhD thesis (Diss. Math. Univ. Tartuensis 23), Dept. of Computer Science, Univ. of Tartu, August 2000.

Appendix A

Coherence Conditions for Linear Actegories

Linear actegories satisfy a large number of coherence conditions. In Section 3.1, we mentioned some of the coherence conditions. Here we listed the rest of the coherence conditions which are as follows:

Symmetries: The following diagrams must commute for symmetries.

$$\begin{array}{ccc}
 A \circ (X \otimes Y) & \xrightarrow{a_{\otimes}^{\circ}} & (A \circ X) \otimes Y \\
 A \circ c_{\otimes} \downarrow & & \downarrow c_{\otimes} \\
 A \circ (Y \otimes X) & \xrightarrow{a_{\otimes'}^{\circ}} & Y \otimes (A \circ X)
 \end{array}
 \qquad
 \begin{array}{ccc}
 Y \oplus (A \bullet X) & \xrightarrow{c_{\oplus}} & (A \bullet X) \oplus Y \\
 a_{\oplus'}^{\bullet} \downarrow & & \downarrow a_{\oplus}^{\bullet} \\
 A \bullet (Y \oplus X) & \xrightarrow{A \bullet c_{\oplus}} & A \bullet (X \oplus Y)
 \end{array}$$

$$a_{\otimes}^{\circ} c_{\otimes} = (A \circ c_{\otimes}) a_{\otimes'}^{\circ} \tag{A.1}$$

$$c_{\oplus} a_{\oplus}^{\bullet} = a_{\oplus'}^{\bullet} (A \bullet c_{\oplus}) \tag{A.2}$$

$$\begin{array}{ccc}
 A \circ (X \oplus Y) & \xrightarrow{d_{\oplus}^{\circ}} & (A \circ X) \oplus Y \\
 A \circ c_{\oplus} \downarrow & & \downarrow c_{\oplus} \\
 A \circ (Y \oplus X) & \xrightarrow{d_{\oplus'}^{\circ}} & Y \oplus (A \circ X)
 \end{array}
 \qquad
 \begin{array}{ccc}
 Y \otimes (A \bullet X) & \xrightarrow{c_{\otimes}} & (A \bullet X) \otimes Y \\
 d_{\otimes'}^{\bullet} \downarrow & & \downarrow d_{\otimes}^{\bullet} \\
 A \bullet (Y \otimes X) & \xrightarrow{A \bullet c_{\otimes}} & A \bullet (X \otimes Y)
 \end{array}$$

$$d_{\oplus}^{\circ} c_{\oplus} = (A \circ c_{\oplus}) a_{\oplus'}^{\circ} \tag{A.3}$$

$$c_{\otimes} d_{\otimes}^{\bullet} = d_{\otimes'}^{\bullet} (A \bullet c_{\otimes}) \tag{A.4}$$

Unit and associativity: The following diagrams must commute for unit and associativity.

$$\begin{array}{ccc}
 (A * I) \circ X & \xrightarrow{a_{\circ}^*} & A \circ (I \circ X) \\
 r_* \circ X \downarrow & \swarrow A \circ u_{\circ} & \\
 A \circ X & &
 \end{array}
 \qquad
 \begin{array}{ccc}
 A \bullet X & \xrightarrow{A \bullet u_{\bullet}} & A \bullet (I \bullet X) \\
 r_*^{-1} \bullet X \downarrow & \swarrow a_{\bullet}^* & \\
 (A * I) \bullet X & &
 \end{array}$$

$$a_{\circ}^* A \circ u_{\circ} = r_* \circ X \tag{A.5}$$

$$(A \bullet u_{\bullet}) a_{\bullet}^* = r_*^{-1} \bullet X \tag{A.6}$$

$$\begin{array}{ccc}
(I * A) \circ X & \xrightarrow{a_o^*} & I \circ (A \circ X) \\
l_* \circ X \downarrow & \swarrow u_o & \\
A \circ X & &
\end{array}
\qquad
\begin{array}{ccc}
A \bullet X & \xrightarrow{u_\bullet} & I \bullet (A \bullet X) \\
l_*^{-1} \bullet X \downarrow & \swarrow a_\bullet^* & \\
(I * A) \bullet X & &
\end{array}$$

$$a_o^* u_o = l_* \circ X \quad (\text{A.7})$$

$$u_\bullet a_\bullet^* = l_*^{-1} \bullet X \quad (\text{A.8})$$

$$\begin{array}{ccc}
A \circ (X \otimes T) & \xrightarrow{a_\otimes^o} & (A \circ X) \otimes T \\
A \circ r_\otimes \downarrow & \swarrow r_\otimes & \\
A \circ X & &
\end{array}
\qquad
\begin{array}{ccc}
A \bullet X & \xrightarrow{r_\oplus} & (A \bullet X) \oplus \perp \\
A \bullet r_\oplus \downarrow & \swarrow a_\oplus^\bullet & \\
A \bullet (X \oplus \perp) & &
\end{array}$$

$$\begin{array}{ccc}
A \circ (T \otimes Y) & \xrightarrow{a_\otimes^o'} & T \otimes (A \circ Y) \\
A \circ l_\otimes \downarrow & \swarrow l_\otimes & \\
A \circ Y & &
\end{array}
\qquad
\begin{array}{ccc}
A \bullet X & \xrightarrow{l_\oplus} & \perp \oplus (A \bullet X) \\
A \bullet l_\oplus \downarrow & \swarrow a_\oplus^{\bullet'} & \\
A \bullet (\perp \oplus X) & &
\end{array}$$

$$a_\otimes^o r_\otimes = A \circ r_\otimes \quad (\text{A.9})$$

$$r_\oplus a_\oplus^\bullet = A \bullet r_\oplus \quad (\text{A.10})$$

$$a_\otimes^o' l_\otimes = A \circ l_\otimes \quad (\text{A.11})$$

$$l_\oplus a_\oplus^{\bullet'} = A \bullet l_\oplus \quad (\text{A.12})$$

Unit and distributivity: The following diagrams must commute for unit and distributivity.

$$\begin{array}{ccc}
A \circ X & \xrightarrow{A \circ r_\oplus} & A \circ (X \oplus \perp) \\
r_\oplus \downarrow & \swarrow d_\oplus^o & \\
(A \circ X) \oplus \perp & &
\end{array}
\qquad
\begin{array}{ccc}
(A \bullet X) \otimes T & \xrightarrow{d_\otimes^\bullet} & A \bullet (X \otimes T) \\
r_\otimes \downarrow & \swarrow A \bullet r_\otimes & \\
A \bullet X & &
\end{array}$$

$$\begin{array}{ccc}
A \circ X & \xrightarrow{A \circ l_\oplus} & A \circ (\perp \oplus X) \\
l_\oplus \downarrow & \swarrow d_\oplus^o' & \\
\perp \oplus (A \circ X) & &
\end{array}
\qquad
\begin{array}{ccc}
T \otimes (A \bullet Y) & \xrightarrow{d_\otimes^{\bullet'}} & A \bullet (T \otimes Y) \\
l_\otimes \downarrow & \swarrow A \bullet l_\otimes & \\
A \bullet Y & &
\end{array}$$

$$(A \circ r_{\oplus}) d_{\oplus}^{\circ} = r_{\oplus} \quad (\text{A.13})$$

$$d_{\otimes}^{\bullet} (A \bullet r_{\otimes}) = r_{\otimes} \quad (\text{A.14})$$

$$(A \circ l_{\oplus}) d_{\oplus'}^{\circ} = l_{\oplus} \quad (\text{A.15})$$

$$d_{\otimes'}^{\bullet} (A \bullet l_{\otimes}) = l_{\otimes} \quad (\text{A.16})$$

$$\begin{array}{ccc} I \circ (X \oplus Y) & \xrightarrow{d_{\oplus}^{\circ}} & (I \circ X) \oplus Y \\ u_{\circ} \downarrow & \swarrow u_{\circ} \oplus Y & \\ X \oplus Y & & \end{array} \quad \begin{array}{ccc} X \otimes Y & \xrightarrow{u_{\bullet} \otimes Y} & (I \bullet X) \otimes Y \\ u_{\bullet} \downarrow & \swarrow d_{\otimes}^{\bullet} & \\ I \bullet (X \otimes Y) & & \end{array}$$

$$\begin{array}{ccc} I \circ (Y \oplus X) & \xrightarrow{d_{\oplus'}^{\circ}} & Y \oplus (I \circ X) \\ u_{\circ} \downarrow & \swarrow Y \oplus u_{\circ} & \\ Y \oplus X & & \end{array} \quad \begin{array}{ccc} Y \otimes X & \xrightarrow{Y \otimes u_{\bullet}} & Y \otimes (I \bullet X) \\ u_{\bullet} \downarrow & \swarrow d_{\otimes'}^{\bullet} & \\ I \bullet (Y \otimes X) & & \end{array}$$

$$d_{\oplus}^{\circ} (u_{\circ} \oplus Y) = u_{\circ} \quad (\text{A.17})$$

$$(u_{\bullet} \otimes Y) d_{\otimes}^{\bullet} = u_{\bullet} \quad (\text{A.18})$$

$$d_{\oplus'}^{\circ} (Y \oplus u_{\circ}) = u_{\circ} \quad (\text{A.19})$$

$$(Y \otimes u_{\bullet}) d_{\otimes'}^{\bullet} = u_{\bullet} \quad (\text{A.20})$$

$$\begin{array}{ccc} I \circ (X \otimes Y) & \xrightarrow{a_{\otimes}^{\circ}} & (I \circ X) \otimes Y \\ u_{\circ} \downarrow & \swarrow u_{\circ} \otimes Y & \\ X \otimes Y & & \end{array} \quad \begin{array}{ccc} X \oplus Y & \xrightarrow{u_{\bullet} \oplus Y} & (I \bullet X) \oplus Y \\ u_{\bullet} \downarrow & \swarrow a_{\oplus}^{\bullet} & \\ I \bullet (X \oplus Y) & & \end{array}$$

$$\begin{array}{ccc} I \circ (Y \otimes X) & \xrightarrow{a_{\otimes'}^{\circ}} & Y \otimes (I \circ X) \\ u_{\circ} \downarrow & \swarrow Y \otimes u_{\circ} & \\ Y \otimes X & & \end{array} \quad \begin{array}{ccc} Y \oplus X & \xrightarrow{Y \oplus u_{\bullet}} & Y \oplus (I \bullet X) \\ u_{\bullet} \downarrow & \swarrow a_{\oplus'}^{\bullet} & \\ I \bullet (Y \oplus X) & & \end{array}$$

$$a_{\otimes}^{\circ} (u_{\circ} \otimes Y) = u_{\circ} \quad (\text{A.21})$$

$$(u_{\bullet} \oplus Y) a_{\oplus}^{\bullet} = u_{\bullet} \quad (\text{A.22})$$

$$a_{\otimes'}^{\circ} (Y \otimes u_{\circ}) = u_{\circ} \quad (\text{A.23})$$

$$(Y \oplus u_{\bullet}) a_{\oplus'}^{\bullet} = u_{\bullet} \quad (\text{A.24})$$

$$\begin{array}{ccc}
I \circ (A \bullet X) & \xrightarrow{d_\bullet^\circ} & A \bullet (I \circ X) \\
u_\circ \downarrow & \swarrow A \bullet u_\circ & \\
A \bullet X & &
\end{array}
\qquad
\begin{array}{ccc}
A \circ X & \xrightarrow{A \circ u_\bullet} & A \circ (I \bullet X) \\
u_\bullet \downarrow & \swarrow d_\bullet^\circ & \\
I \bullet (A \circ X) & &
\end{array}$$

$$d_\bullet^\circ (A \bullet u_\circ) = u_\circ \quad (\text{A.25})$$

$$(A \circ u_\bullet) d_\bullet^\circ = u_\bullet \quad (\text{A.26})$$

Associativity: The following diagrams must commute for associativity.

$$\begin{array}{ccc}
((A * B) * C) \circ X & \xrightarrow{a_* \circ X} & (A * (B * C)) \circ X \\
a_\circ^* \downarrow & & \downarrow a_\circ^* \\
(A * B) \circ (C \circ X) & \xrightarrow{a_\circ^*} & A \circ ((B * C) \circ X) \\
& & \downarrow A \circ a_\circ^* \\
& & A \circ (B \circ (C \circ X))
\end{array}
\qquad
\begin{array}{ccc}
A \bullet (B \bullet (C \bullet X)) & \xrightarrow{A \bullet a_\bullet^*} & A \bullet ((B * C) \bullet X) \\
a_\bullet^* \downarrow & & \downarrow a_\bullet^* \\
(A * B) \bullet (C \bullet X) & \xrightarrow{a_\bullet^*} & ((A * B) * C) \bullet X \\
& & \downarrow a_*^{-1} \bullet X \\
& & ((A * B) * C) \bullet X
\end{array}$$

$$\begin{array}{ccc}
(C * (B * A)) \circ X & \xrightarrow{a_*^{-1} \circ X} & ((C * B) * A) \circ X \\
a_\circ^{*'} \downarrow & & \downarrow a_\circ^{*'} \\
(B * A) \circ (C \circ X) & \xrightarrow{a_\circ^{*'}} & A \circ ((C * B) \circ X) \\
& & \downarrow A \circ a_\circ^{*'} \\
& & A \circ (B \circ (C \circ X))
\end{array}
\qquad
\begin{array}{ccc}
A \bullet (B \bullet (C \bullet X)) & \xrightarrow{A \bullet a_\bullet^{*'}} & A \bullet ((C * B) \bullet X) \\
a_\bullet^{*'} \downarrow & & \downarrow a_\bullet^{*'} \\
(B * A) \bullet (C \bullet X) & \xrightarrow{a_\bullet^{*'}} & ((C * B) * A) \bullet X \\
& & \downarrow a_* \bullet X \\
& & (C * (B * A)) \bullet X
\end{array}$$

$$(a_* \circ X) a_\circ^* (A \circ a_\circ^*) = a_\circ^* a_*^* \quad (\text{A.27})$$

$$(A \bullet a_\bullet^*) a_\bullet^* (a_*^{-1} \bullet X) = a_\bullet^* a_*^* \quad (\text{A.28})$$

$$(a_*^{-1} \circ X) a_\circ^{*'} (A \circ a_\circ^{*'}) = a_\circ^{*'} a_*^{*'} \quad (\text{A.29})$$

$$(A \bullet a_\bullet^{*'}) a_\bullet^{*'} (a_* \bullet X) = a_\bullet^{*'} a_*^{*'} \quad (\text{A.30})$$

$$\begin{array}{ccc}
(A * B) \circ (C \bullet X) & \xrightarrow{a_\circ^*} & A \circ (B \circ (C \bullet X)) \\
d_\bullet^\circ \downarrow & & \downarrow A \circ d_\bullet^\circ \\
C \bullet ((A * B) \circ X) & \xrightarrow{C \bullet a_\circ^*} & C \bullet (A \circ (B \circ X)) \\
& & \downarrow d_\bullet^\circ \\
& & C \bullet (A \circ (B \circ X))
\end{array}
\qquad
\begin{array}{ccc}
C \circ (A \bullet (B \bullet X)) & \xrightarrow{d_\bullet^\circ} & A \bullet (C \circ B \bullet X) \\
C \circ a_\bullet^* \downarrow & & \downarrow A \bullet d_\bullet^\circ \\
C \circ ((A * B) \bullet X) & \xrightarrow{d_\bullet^\circ} & (A * B) \bullet (C \circ X) \\
& & \downarrow a_\bullet^* \\
& & (A * B) \bullet (C \circ X)
\end{array}$$

$$\begin{array}{ccc}
(B * A) \circ (C \bullet X) & \xrightarrow{a_{\circ}^{*'}} & A \circ (B \circ (C \bullet X)) \\
\downarrow d_{\bullet}^{\circ} & & \downarrow A \circ d_{\bullet}^{\circ} \\
C \bullet ((B * A) \circ X) & \xrightarrow{C \bullet a_{\circ}^{*'}} & C \bullet (A \circ (B \circ X))
\end{array}
\qquad
\begin{array}{ccc}
C \circ (A \bullet (B \bullet X)) & \xrightarrow{d_{\bullet}^{\circ}} & A \bullet (C \circ B \bullet X) \\
\downarrow C \circ a_{\bullet}^{*'} & & \downarrow A \bullet d_{\bullet}^{\circ} \\
C \circ ((B * A) \bullet X) & \xrightarrow{d_{\bullet}^{\circ}} & (B * A) \bullet (C \circ X)
\end{array}$$

$$d_{\circ}^{*} (A \circ d_{\bullet}^{\circ}) d_{\bullet}^{\circ} = d_{\bullet}^{\circ} (C \bullet a_{\circ}^{*}) \quad (\text{A.31})$$

$$d_{\bullet}^{\circ} (A \bullet d_{\bullet}^{\circ}) a_{\bullet}^{*} = (C \circ a_{\bullet}^{*}) d_{\bullet}^{\circ} \quad (\text{A.32})$$

$$a_{\circ}^{*'} (A \circ d_{\bullet}^{\circ}) d_{\bullet}^{\circ} = d_{\bullet}^{\circ} (C \bullet a_{\circ}^{*'}) \quad (\text{A.33})$$

$$d_{\bullet}^{\circ} (A \bullet d_{\bullet}^{\circ}) a_{\bullet}^{*'} = (C \circ a_{\bullet}^{*'}) d_{\bullet}^{\circ} \quad (\text{A.34})$$

$$\begin{array}{ccc}
(A * B) \circ (X \otimes Y) & \xrightarrow{a_{\circ}^{*}} & A \circ (B \circ (X \otimes Y)) \\
\downarrow a_{\otimes}^{\circ} & & \downarrow A \circ a_{\otimes}^{\circ} \\
((A * B) \circ X) \otimes Y & \xrightarrow{a_{\otimes}^{*} \otimes Y} & (A \circ (B \circ X)) \otimes Y
\end{array}
\qquad
\begin{array}{ccc}
(A * B) \circ (Y \otimes X) & \xrightarrow{a_{\circ}^{*}} & A \circ (B \circ (Y \otimes X)) \\
\downarrow a_{\otimes}^{\circ'} & & \downarrow A \circ a_{\otimes}^{\circ'} \\
Y \otimes ((A * B) \circ X) & \xrightarrow{Y \otimes a_{\circ}^{*}} & Y \otimes (A \circ (B \circ X))
\end{array}$$

$$\begin{array}{ccc}
(B * A) \circ (X \otimes Y) & \xrightarrow{a_{\circ}^{*'}} & A \circ (B \circ (X \otimes Y)) \\
\downarrow a_{\otimes}^{\circ} & & \downarrow A \circ a_{\otimes}^{\circ} \\
((B * A) \circ X) \otimes Y & \xrightarrow{a_{\otimes}^{*'} \otimes Y} & (A \circ (B \circ X)) \otimes Y
\end{array}
\qquad
\begin{array}{ccc}
(B * A) \circ (Y \otimes X) & \xrightarrow{a_{\circ}^{*'}} & A \circ (B \circ (Y \otimes X)) \\
\downarrow a_{\otimes}^{\circ'} & & \downarrow A \circ a_{\otimes}^{\circ'} \\
Y \otimes ((B * A) \circ X) & \xrightarrow{Y \otimes a_{\circ}^{*'}} & Y \otimes (A \circ (B \circ X))
\end{array}$$

$$\begin{array}{ccc}
(A \bullet (B \bullet X)) \oplus Y & \xrightarrow{a_{\oplus}^{*}} & A \bullet ((B \bullet X) \oplus Y) \\
\downarrow a_{\oplus}^{*} \oplus Y & & \downarrow A \bullet a_{\oplus}^{*} \\
((A * B) \bullet X) \oplus Y & \xrightarrow{a_{\oplus}^{*}} & (A * B) \bullet (X \oplus Y)
\end{array}
\qquad
\begin{array}{ccc}
Y \oplus (A \bullet (B \bullet X)) & \xrightarrow{a_{\oplus}^{*'}} & A \bullet (Y \oplus (B \bullet X)) \\
\downarrow Y \oplus a_{\oplus}^{*} & & \downarrow A \bullet a_{\oplus}^{*'} \\
Y \oplus ((A * B) \bullet X) & \xrightarrow{a_{\oplus}^{*'}} & (A * B) \bullet (Y \oplus X)
\end{array}$$

$$\begin{array}{ccc}
(A \bullet (B \bullet X)) \oplus Y & \xrightarrow{a_{\oplus}^{\bullet}} & A \bullet ((B \bullet X) \oplus Y) \\
\downarrow a_{\oplus}^{\bullet'} & & \downarrow A \bullet a_{\oplus}^{\bullet} \\
((B \bullet A) \bullet X) \oplus Y & \xrightarrow{a_{\oplus}^{\bullet}} & (B \bullet A) \bullet (X \oplus Y) \\
& & \downarrow a_{\oplus}^{\bullet'} \\
& & A \bullet (B \bullet (X \oplus Y))
\end{array}
\qquad
\begin{array}{ccc}
Y \oplus (A \bullet (B \bullet X)) & \xrightarrow{a_{\oplus}^{\bullet'}} & A \bullet (Y \oplus (B \bullet X)) \\
\downarrow Y \oplus a_{\oplus}^{\bullet'} & & \downarrow A \bullet a_{\oplus}^{\bullet'} \\
Y \oplus ((B \bullet A) \bullet X) & \xrightarrow{a_{\oplus}^{\bullet'}} & (B \bullet A) \bullet (Y \oplus X) \\
& & \downarrow a_{\oplus}^{\bullet'} \\
& & A \bullet (B \bullet (Y \oplus X))
\end{array}$$

$$a_{\circ}^* (A \circ a_{\otimes}^{\circ}) a_{\otimes}^{\circ} = a_{\otimes}^{\circ} (a_{\circ}^* \otimes Y) \quad (\text{A.35})$$

$$a_{\circ}^* (A \circ a_{\otimes'}^{\circ}) a_{\otimes'}^{\circ} = a_{\otimes'}^{\circ} (Y \otimes a_{\circ}^*) \quad (\text{A.36})$$

$$a_{\circ}^{\bullet'} (A \circ a_{\otimes}^{\circ}) a_{\otimes}^{\circ} = a_{\otimes}^{\circ} (a_{\circ}^{\bullet'} \otimes Y) \quad (\text{A.37})$$

$$a_{\circ}^{\bullet'} (A \circ a_{\otimes'}^{\circ}) a_{\otimes'}^{\circ} = a_{\otimes'}^{\circ} (Y \otimes a_{\circ}^{\bullet'}) \quad (\text{A.38})$$

$$a_{\oplus}^{\bullet} (A \bullet a_{\oplus}^{\bullet}) a_{\bullet}^* = (a_{\bullet}^* \oplus Y) a_{\oplus}^{\bullet} \quad (\text{A.39})$$

$$a_{\oplus}^{\bullet} (A \bullet a_{\oplus'}^{\bullet}) a_{\bullet}^* = (Y \oplus a_{\bullet}^*) a_{\oplus}^{\bullet} \quad (\text{A.40})$$

$$a_{\oplus}^{\bullet} (A \bullet a_{\oplus}^{\bullet}) a_{\bullet}^{\bullet'} = (a_{\bullet}^{\bullet'} \oplus Y) a_{\oplus}^{\bullet} \quad (\text{A.41})$$

$$a_{\oplus}^{\bullet} (A \bullet a_{\oplus'}^{\bullet}) a_{\bullet}^{\bullet'} = (Y \oplus a_{\bullet}^{\bullet'}) a_{\oplus}^{\bullet} \quad (\text{A.42})$$

$$\begin{array}{ccc}
A \circ ((X \otimes Y) \otimes Z) & \xrightarrow{a_{\otimes}^{\circ}} & (A \circ (X \otimes Y)) \otimes Z \\
\downarrow A \circ a_{\otimes}^{\circ} & & \downarrow a_{\otimes}^{\circ} \otimes Z \\
A \circ (X \otimes (Y \otimes Z)) & \xrightarrow{a_{\otimes}^{\circ}} & (A \circ X) \otimes (Y \otimes Z) \\
& & \downarrow a_{\otimes}^{\circ} \\
& & ((A \circ X) \otimes Y) \otimes Z
\end{array}
\qquad
\begin{array}{ccc}
(A \bullet X) \oplus (Y \oplus Z) & \xrightarrow{a_{\oplus}^{\bullet}} & ((A \bullet X) \oplus Y) \oplus Z \\
\downarrow a_{\oplus}^{\bullet} & & \downarrow a_{\oplus}^{\bullet} \oplus Z \\
A \bullet (X \oplus (Y \oplus Z)) & \xrightarrow{A \bullet a_{\oplus}^{\bullet}} & (A \bullet (X \oplus Y)) \oplus Z \\
& & \downarrow a_{\oplus}^{\bullet} \\
& & A \bullet ((X \oplus Y) \oplus Z)
\end{array}$$

$$\begin{array}{ccc}
A \circ (Z \otimes (X \otimes Y)) & \xrightarrow{a_{\otimes'}^{\circ}} & Z \otimes (A \circ (X \otimes Y)) \\
\downarrow A \circ a_{\otimes}^{-1} & & \downarrow Z \otimes a_{\otimes'}^{\circ} \\
A \circ ((Z \otimes X) \otimes Y) & \xrightarrow{a_{\otimes'}^{\circ}} & (Z \otimes X) \otimes (A \circ Y) \\
& & \downarrow a_{\otimes}^{-1} \\
& & Z \otimes (X \otimes (A \circ Y))
\end{array}
\qquad
\begin{array}{ccc}
(Z \oplus X) \oplus (A \bullet Y) & \xrightarrow{a_{\oplus}^{-1}} & Z \oplus (X \oplus (A \bullet Y)) \\
\downarrow a_{\oplus}^{\bullet'} & & \downarrow Z \oplus a_{\oplus}^{\bullet'} \\
A \bullet ((Z \oplus X) \oplus Y) & \xrightarrow{A \bullet a_{\oplus}^{-1}} & A \bullet (Z \oplus (X \oplus Y)) \\
& & \downarrow a_{\oplus}^{\bullet'} \\
& & Z \oplus (A \bullet (X \oplus Y))
\end{array}$$

$$a_{\otimes}^{\circ} (a_{\otimes}^{\circ} \otimes Z) a_{\otimes} = (A \circ a_{\otimes}) (a_{\otimes}^{\circ}) \quad (\text{A.43})$$

$$a_{\oplus} (a_{\oplus}^{\bullet} \oplus Z) a_{\oplus}^{\bullet} = a_{\oplus}^{\bullet} (A \bullet a_{\oplus}) \quad (\text{A.44})$$

$$a_{\otimes'}^{\circ} (Z \otimes a_{\otimes'}^{\circ}) a_{\otimes}^{-1} = (A \circ a_{\otimes}^{-1}) a_{\otimes'}^{\circ} \quad (\text{A.45})$$

$$a_{\oplus}^{-1} (Z \oplus a_{\oplus'}^{\bullet}) a_{\oplus}^{\bullet} = a_{\oplus'}^{\bullet} (A \bullet a_{\oplus}^{-1}) \quad (\text{A.46})$$

$$\begin{array}{ccc} (A * B) \circ (X \otimes Y) & \xrightarrow{a_{\circ}^*} & A \circ (B \circ (X \otimes Y)) \\ \downarrow a_{\circ}^{*'} & & \downarrow A \circ a_{\otimes'}^{\circ} \\ B \circ (A \circ (X \otimes Y)) & & A \circ (X \otimes (B \circ Y)) \\ \downarrow B \circ a_{\otimes}^{\circ} & & \downarrow a_{\otimes}^{\circ} \\ B \circ ((A \circ X) \otimes Y) & \xrightarrow{a_{\otimes'}^{\circ}} & (A \circ X) \otimes (B \circ Y) \end{array} \quad \begin{array}{ccc} (A \bullet X) \oplus (B \bullet Y) & \xrightarrow{a_{\oplus}^{\bullet}} & A \bullet (X \oplus (B \bullet Y)) \\ \downarrow a_{\oplus'}^{\bullet} & & \downarrow A \bullet a_{\oplus'}^{\bullet} \\ B \bullet ((A \bullet X) \oplus Y) & & A \bullet (B \bullet (X \oplus Y)) \\ \downarrow B \bullet a_{\oplus}^{\bullet} & & \downarrow a_{\oplus}^{\bullet} \\ B \bullet (A \bullet (X \oplus Y)) & \xrightarrow{a_{\oplus'}^{\bullet}} & (A * B) \bullet (X \oplus Y) \end{array}$$

$$\begin{array}{ccc} (A * B) \circ (X \otimes Y) & \xrightarrow{a_{\circ}^*} & A \circ (B \circ (X \otimes Y)) \\ \downarrow a_{\circ}^{*'} & & \downarrow A \circ a_{\otimes}^{\circ} \\ B \circ (A \circ (X \otimes Y)) & & A \circ ((B \circ X) \otimes Y) \\ \downarrow B \circ a_{\otimes'}^{\circ} & & \downarrow a_{\otimes'}^{\circ} \\ B \circ (X \otimes (A \circ Y)) & \xrightarrow{a_{\otimes}^{\circ}} & (B \circ X) \otimes (A \circ Y) \end{array} \quad \begin{array}{ccc} (B \bullet X) \oplus (A \bullet Y) & \xrightarrow{a_{\oplus'}^{\bullet}} & A \bullet ((B \bullet X) \oplus Y) \\ \downarrow a_{\oplus}^{\bullet} & & \downarrow A \bullet a_{\oplus}^{\bullet} \\ B \bullet (X \oplus (A \bullet Y)) & & A \bullet (B \bullet (X \oplus Y)) \\ \downarrow B \bullet a_{\oplus'}^{\bullet} & & \downarrow a_{\oplus}^{\bullet} \\ B \bullet (A \bullet (X \oplus Y)) & \xrightarrow{a_{\oplus'}^{\bullet}} & (A * B) \bullet (X \oplus Y) \end{array}$$

$$a_{\circ}^* (A \circ a_{\otimes'}^{\circ}) a_{\otimes}^{\circ} = a_{\circ}^{*'} (B \circ a_{\otimes}^{\circ}) a_{\otimes'}^{\circ} \quad (\text{A.47})$$

$$a_{\oplus}^{\bullet} (A \bullet a_{\oplus'}^{\bullet}) a_{\oplus}^* = a_{\oplus'}^{\bullet} (B \bullet a_{\oplus}^{\bullet}) a_{\oplus}^{*'} \quad (\text{A.48})$$

$$a_{\circ}^* (A \circ a_{\otimes}^{\circ}) a_{\otimes'}^{\circ} = a_{\circ}^{*'} (B \circ a_{\otimes'}^{\circ}) a_{\otimes}^{\circ} \quad (\text{A.49})$$

$$a_{\oplus}^{\bullet} (A \bullet a_{\oplus}^{\bullet}) a_{\oplus}^* = a_{\oplus}^{\bullet} (B \bullet a_{\oplus'}^{\bullet}) a_{\oplus}^{*'} \quad (\text{A.50})$$

Distributivity and associativity: The following diagrams must commute for distributivity and associativity.

$$\begin{array}{ccc} (A * B) \circ (X \oplus Y) & \xrightarrow{a_{\circ}^*} & A \circ (B \circ (X \oplus Y)) \\ \downarrow d_{\oplus}^{\circ} & & \downarrow A \circ d_{\oplus}^{\circ} \\ ((A * B) \circ X) \oplus Y & \xrightarrow{a_{\oplus}^{\circ} \oplus Y} & (A \circ (B \circ X)) \oplus Y \end{array} \quad \begin{array}{ccc} (A * B) \circ (Y \oplus X) & \xrightarrow{a_{\circ}^*} & A \circ (B \circ (Y \oplus X)) \\ \downarrow d_{\oplus'}^{\circ} & & \downarrow A \circ d_{\oplus'}^{\circ} \\ Y \oplus ((A * B) \circ X) & \xrightarrow{Y \oplus a_{\circ}^*} & Y \oplus (A \circ (B \circ X)) \end{array}$$

$$\begin{array}{ccc}
(B * A) \circ (X \oplus Y) & \xrightarrow{a_{\circ}^{*'}} & A \circ (B \circ (X \oplus Y)) \\
\downarrow d_{\oplus}^{\circ} & & \downarrow A \circ d_{\oplus}^{\circ} \\
((B * A) \circ X) \oplus Y & \xrightarrow{a_{\circ}^{*'} \oplus Y} & (A \circ (B \circ X)) \oplus Y
\end{array}
\qquad
\begin{array}{ccc}
(B * A) \circ (Y \oplus X) & \xrightarrow{a_{\circ}^{*'}} & A \circ (B \circ (Y \oplus X)) \\
\downarrow d_{\oplus'}^{\circ} & & \downarrow A \circ d_{\oplus'}^{\circ} \\
Y \oplus ((B * A) \circ X) & \xrightarrow{Y \oplus a_{\circ}^{*'}} & Y \oplus (A \circ (B \circ X))
\end{array}$$

$$\begin{array}{ccc}
(A \bullet (B \bullet X)) \otimes Y & \xrightarrow{d_{\otimes}^{\bullet}} & A \bullet ((B \bullet X) \otimes Y) \\
\downarrow a_{\bullet}^{*} \otimes Y & & \downarrow A \bullet d_{\otimes}^{\bullet} \\
((A * B) \bullet X) \otimes Y & \xrightarrow{d_{\otimes}^{\bullet}} & (A * B) \bullet (X \otimes Y)
\end{array}
\qquad
\begin{array}{ccc}
Y \otimes (A \bullet (B \bullet X)) & \xrightarrow{d_{\otimes'}^{\bullet}} & A \bullet (Y \otimes (B \bullet X)) \\
\downarrow Y \otimes a_{\bullet}^{*} & & \downarrow A \bullet d_{\otimes'}^{\bullet} \\
Y \otimes ((A * B) \bullet X) & \xrightarrow{d_{\otimes'}^{\bullet}} & (A * B) \bullet (Y \otimes X)
\end{array}$$

$$\begin{array}{ccc}
(A \bullet (B \bullet X)) \otimes Y & \xrightarrow{d_{\otimes}^{\bullet}} & A \bullet ((B \bullet X) \otimes Y) \\
\downarrow a_{\bullet}^{*'} \otimes Y & & \downarrow A \bullet d_{\otimes}^{\bullet} \\
((B * A) \bullet X) \otimes Y & \xrightarrow{d_{\otimes}^{\bullet}} & (B * A) \bullet (X \otimes Y)
\end{array}
\qquad
\begin{array}{ccc}
Y \otimes (A \bullet (B \bullet X)) & \xrightarrow{d_{\otimes'}^{\bullet}} & A \bullet (Y \otimes (B \bullet X)) \\
\downarrow Y \otimes a_{\bullet}^{*'} & & \downarrow A \bullet d_{\otimes'}^{\bullet} \\
Y \otimes ((B * A) \bullet X) & \xrightarrow{d_{\otimes'}^{\bullet}} & (B * A) \bullet (Y \otimes X)
\end{array}$$

$$a_{\circ}^{*} (A \circ d_{\oplus}^{\circ}) d_{\oplus}^{\circ} = d_{\oplus}^{\circ} (a_{\circ}^{*} \oplus Y) \quad (\text{A.51})$$

$$a_{\circ}^{*} (A \circ d_{\oplus'}^{\circ}) d_{\oplus'}^{\circ} = d_{\oplus'}^{\circ} (Y \oplus a_{\circ}^{*}) \quad (\text{A.52})$$

$$a_{\circ}^{*'} (A \circ d_{\oplus}^{\circ}) d_{\oplus}^{\circ} = d_{\oplus}^{\circ} (a_{\circ}^{*'} \oplus Y) \quad (\text{A.53})$$

$$a_{\circ}^{*'} (A \circ d_{\oplus'}^{\circ}) d_{\oplus'}^{\circ} = d_{\oplus'}^{\circ} (Y \oplus a_{\circ}^{*'}) \quad (\text{A.54})$$

$$d_{\otimes}^{\bullet} (A \bullet d_{\otimes}^{\bullet}) a_{\bullet}^{*} = (a_{\bullet}^{*} \otimes Y) d_{\otimes}^{\bullet} \quad (\text{A.55})$$

$$d_{\otimes'}^{\bullet} (A \bullet d_{\otimes'}^{\bullet}) a_{\bullet}^{*} = (Y \otimes a_{\bullet}^{*}) d_{\otimes'}^{\bullet} \quad (\text{A.56})$$

$$d_{\otimes}^{\bullet} (A \bullet d_{\otimes}^{\bullet}) a_{\bullet}^{*'} = (a_{\bullet}^{*'} \otimes Y) d_{\otimes}^{\bullet} \quad (\text{A.57})$$

$$d_{\otimes'}^{\bullet} (A \bullet d_{\otimes'}^{\bullet}) a_{\bullet}^{*'} = (Y \otimes a_{\bullet}^{*'}) d_{\otimes'}^{\bullet} \quad (\text{A.58})$$

$$\begin{array}{ccc}
A \circ ((B \bullet X) \otimes Y) & \xrightarrow{A \circ d_{\otimes}^{\bullet}} & A \circ (B \bullet (X \otimes Y)) \\
\downarrow a_{\otimes'}^{\circ} & & \downarrow d_{\bullet}^{\circ} \\
(B \bullet A) \otimes (A \circ Y) & \xrightarrow{d_{\otimes}^{\bullet}} & B \bullet (A \circ (X \otimes Y)) \\
& & \downarrow B \bullet a_{\otimes'}^{\circ} \\
& & B \bullet (X \otimes (A \circ Y))
\end{array}
\qquad
\begin{array}{ccc}
B \circ (X \oplus (A \bullet Y)) & \xrightarrow{B \circ a_{\oplus'}^{\bullet}} & B \circ (A \bullet (X \oplus Y)) \\
\downarrow d_{\oplus}^{\circ} & & \downarrow d_{\bullet}^{\circ} \\
(B \circ X) \oplus (A \bullet Y) & \xrightarrow{a_{\oplus'}^{\bullet}} & A \bullet (B \circ (X \oplus Y)) \\
& & \downarrow A \bullet d_{\oplus}^{\circ} \\
& & A \bullet ((B \circ X) \oplus Y)
\end{array}$$

$$\begin{array}{ccc}
A \circ (X \otimes (B \bullet Y)) & \xrightarrow{A \circ d_{\otimes'}^{\bullet}} & A \circ (B \bullet (X \otimes Y)) \\
\downarrow a_{\otimes}^{\circ} & & \downarrow d_{\bullet}^{\circ} \\
(A \circ X) \otimes (B \bullet Y) & \xrightarrow{d_{\otimes'}^{\bullet}} & B \bullet (A \circ (X \otimes Y)) \\
& & \downarrow B \bullet a_{\otimes}^{\circ} \\
& & B \bullet ((A \circ X) \otimes Y)
\end{array}
\qquad
\begin{array}{ccc}
B \circ ((A \bullet X) \oplus Y) & \xrightarrow{B \circ a_{\oplus}^{\bullet}} & B \circ (A \bullet (X \oplus Y)) \\
\downarrow d_{\oplus'}^{\circ} & & \downarrow d_{\bullet}^{\circ} \\
(A \bullet X) \oplus (B \circ Y) & \xrightarrow{a_{\oplus}^{\bullet}} & A \bullet (B \circ (X \oplus Y)) \\
& & \downarrow A \bullet d_{\oplus'}^{\circ} \\
& & A \bullet (X \oplus (B \circ Y))
\end{array}$$

$$(A \circ d_{\otimes}^{\bullet}) d_{\bullet}^{\circ} (B \bullet a_{\otimes'}^{\circ}) = a_{\otimes'}^{\circ} d_{\otimes}^{\bullet} \quad (\text{A.59})$$

$$(B \circ a_{\oplus'}^{\bullet}) d_{\bullet}^{\circ} (A \bullet d_{\oplus}^{\circ}) = d_{\oplus}^{\circ} a_{\oplus'}^{\bullet} \quad (\text{A.60})$$

$$(A \circ d_{\otimes'}^{\bullet}) d_{\bullet}^{\circ} (B \bullet a_{\otimes}^{\circ}) = a_{\otimes}^{\circ} d_{\otimes'}^{\bullet} \quad (\text{A.61})$$

$$(B \circ a_{\oplus}^{\bullet}) d_{\bullet}^{\circ} (A \bullet d_{\oplus'}^{\circ}) = d_{\oplus'}^{\circ} a_{\oplus}^{\bullet} \quad (\text{A.62})$$

$$\begin{array}{ccc}
A \circ (X \otimes (Y \oplus Z)) & \xrightarrow{A \circ d_{\otimes}^{\oplus}} & A \circ ((X \otimes Y) \oplus Z) \\
\downarrow a_{\otimes}^{\circ} & & \downarrow d_{\oplus}^{\circ} \\
(A \circ X) \otimes (Y \oplus Z) & \xrightarrow{d_{\otimes}^{\oplus}} & (A \circ (X \otimes Y)) \oplus Z \\
& & \downarrow a_{\otimes}^{\circ} \oplus Z \\
& & ((A \circ X) \otimes Y) \oplus Z
\end{array}
\qquad
\begin{array}{ccc}
A \circ (X \otimes (Z \oplus Y)) & \xrightarrow{A \circ d_{\otimes'}^{\oplus}} & A \circ (Z \oplus (X \otimes Y)) \\
\downarrow a_{\otimes}^{\circ} & & \downarrow d_{\oplus'}^{\circ} \\
(A \circ X) \otimes (Z \oplus Y) & \xrightarrow{d_{\otimes'}^{\oplus}} & Z \oplus (A \circ (X \otimes Y)) \\
& & \downarrow Z \oplus a_{\otimes}^{\circ} \\
& & Z \oplus ((A \circ X) \otimes Y)
\end{array}$$

$$\begin{array}{ccc}
A \circ ((Y \oplus Z) \otimes X) & \xrightarrow{A \circ d_{\otimes'}^{\oplus'}} & A \circ ((Y \otimes X) \oplus Z) \\
\downarrow a_{\otimes'}^{\circ} & & \downarrow d_{\oplus}^{\circ} \\
(Y \oplus Z) \otimes (A \circ X) & \xrightarrow{d_{\otimes'}^{\oplus'}} & (A \circ (Y \otimes X)) \oplus Z \\
& & \downarrow a_{\otimes'}^{\circ} \oplus Z \\
& & (Y \otimes (A \circ X)) \oplus Z
\end{array}
\qquad
\begin{array}{ccc}
A \circ ((Z \oplus Y) \otimes X) & \xrightarrow{A \circ d_{\otimes}^{\oplus'}} & A \circ (Z \oplus (Y \otimes X)) \\
\downarrow a_{\otimes'}^{\circ} & & \downarrow d_{\oplus'}^{\circ} \\
(Z \oplus Y) \otimes (A \circ X) & \xrightarrow{d_{\otimes}^{\oplus'}} & Z \oplus (A \circ (Y \otimes X)) \\
& & \downarrow Z \oplus a_{\otimes'}^{\circ} \\
& & Z \oplus (Y \otimes (A \circ X))
\end{array}$$

$$\begin{array}{ccc}
((A \bullet X) \oplus Y) \otimes Z & \xrightarrow{a_{\oplus}^{\bullet} \otimes Z} & (A \bullet (X \oplus Y)) \otimes Z \\
\downarrow d_{\otimes}^{\oplus} & & \downarrow d_{\otimes}^{\bullet} \\
(A \bullet X) \oplus (Y \otimes Z) & \xrightarrow{a_{\oplus}^{\bullet}} & A \bullet ((X \oplus Y) \otimes Z) \\
& & \downarrow A \bullet d_{\otimes}^{\oplus} \\
& & A \bullet (X \oplus (Y \otimes Z))
\end{array}
\qquad
\begin{array}{ccc}
Z \otimes ((A \bullet X) \oplus Y) & \xrightarrow{Z \otimes a_{\oplus}^{\bullet}} & Z \otimes (A \bullet (X \oplus Y)) \\
\downarrow d_{\otimes}^{\otimes'} & & \downarrow d_{\otimes}^{\bullet'} \\
(A \bullet X) \oplus (Z \otimes Y) & \xrightarrow{a_{\oplus}^{\bullet}} & A \bullet (Z \otimes (X \oplus Y)) \\
& & \downarrow A \bullet d_{\otimes}^{\otimes'} \\
& & A \bullet (X \oplus (Z \otimes Y))
\end{array}$$

$$\begin{array}{ccc}
(X \oplus (A \bullet Y)) \otimes Z & \xrightarrow{a_{\oplus'}^{\bullet} \otimes Z} & (A \bullet (X \oplus Y)) \otimes Z \\
\downarrow d_{\otimes}^{\oplus'} & & \downarrow d_{\otimes}^{\bullet} \\
(X \otimes Z) \oplus (A \bullet Y) & \xrightarrow{a_{\oplus'}^{\bullet}} & A \bullet ((X \oplus Y) \otimes Z) \\
& & \downarrow A \bullet d_{\otimes}^{\oplus'} \\
& & A \bullet (X \otimes Z) \oplus Y
\end{array}
\qquad
\begin{array}{ccc}
Z \otimes (X \oplus (A \bullet Y)) & \xrightarrow{Z \otimes a_{\oplus'}^{\bullet}} & Z \otimes (A \bullet (X \oplus Y)) \\
\downarrow d_{\otimes}^{\oplus} & & \downarrow d_{\otimes}^{\bullet'} \\
(Z \otimes X) \oplus (A \bullet Y) & \xrightarrow{a_{\oplus'}^{\bullet}} & A \bullet (Z \otimes (X \oplus Y)) \\
& & \downarrow A \bullet d_{\otimes}^{\oplus} \\
& & A \bullet ((Z \otimes X) \oplus Y)
\end{array}$$

$$(A \circ d_{\oplus}^{\otimes}) d_{\oplus}^{\circ} (a_{\otimes}^{\circ} \oplus Z) = a_{\otimes}^{\circ} d_{\oplus}^{\otimes} \quad (\text{A.63})$$

$$(A \circ d_{\oplus}^{\otimes'}) d_{\oplus}^{\otimes'} (Z \oplus a_{\otimes}^{\circ}) = a_{\otimes}^{\circ} d_{\oplus}^{\otimes'} \quad (\text{A.64})$$

$$(A \circ d_{\oplus}^{\oplus'}) d_{\oplus}^{\circ} (a_{\otimes'}^{\circ} \oplus Z) = a_{\otimes'}^{\circ} d_{\oplus}^{\oplus'} \quad (\text{A.65})$$

$$(A \circ d_{\oplus}^{\oplus}) d_{\oplus}^{\circ'} (Z \oplus a_{\otimes'}^{\circ}) = a_{\otimes'}^{\circ} d_{\oplus}^{\oplus} \quad (\text{A.66})$$

$$(a_{\oplus}^{\bullet} \otimes Z) d_{\otimes}^{\bullet} (A \bullet d_{\oplus}^{\oplus}) = d_{\oplus}^{\oplus} a_{\oplus}^{\bullet} \quad (\text{A.67})$$

$$(Z \otimes a_{\oplus}^{\bullet}) d_{\otimes}^{\bullet'} (A \bullet d_{\oplus}^{\otimes'}) = d_{\oplus}^{\otimes'} a_{\oplus}^{\bullet} \quad (\text{A.68})$$

$$(a_{\oplus'}^{\bullet} \otimes Z) d_{\otimes}^{\bullet} (A \bullet d_{\oplus}^{\oplus'}) = d_{\oplus}^{\oplus'} a_{\oplus'}^{\bullet} \quad (\text{A.69})$$

$$(Z \otimes a_{\oplus'}^{\bullet}) d_{\otimes}^{\bullet'} (A \bullet d_{\oplus}^{\otimes}) = d_{\oplus}^{\otimes} a_{\oplus'}^{\bullet} \quad (\text{A.70})$$

$$\begin{array}{ccc}
A \circ ((Y \oplus Z) \otimes X) & \xrightarrow{a_{\otimes}^{\circ}} & (A \circ (Y \oplus Z)) \otimes X \\
\downarrow A \circ d_{\otimes}^{\oplus} & & \downarrow d_{\otimes}^{\circ} \otimes X \\
A \circ (Y \oplus (Z \otimes X)) & \xrightarrow{d_{\oplus}^{\circ}} & ((A \circ Y) \oplus Z) \otimes X \\
& & \downarrow d_{\otimes}^{\oplus} \\
& & (A \circ Y) \oplus (Z \otimes X)
\end{array}
\qquad
\begin{array}{ccc}
A \circ ((Y \oplus Z) \otimes X) & \xrightarrow{a_{\otimes}^{\circ}} & (A \circ (Y \oplus Z)) \otimes X \\
\downarrow A \circ d_{\otimes}^{\oplus'} & & \downarrow d_{\otimes}^{\circ'} \otimes X \\
A \circ ((Y \otimes X) \oplus Z) & \xrightarrow{d_{\oplus}^{\circ'}} & (Y \circ (A \oplus Z)) \otimes X \\
& & \downarrow d_{\otimes}^{\oplus'} \\
& & (Y \otimes X) \oplus (A \circ Z)
\end{array}$$

$$\begin{array}{ccc}
A \circ (X \otimes (Y \oplus Z)) & \xrightarrow{a_{\otimes'}^{\circ}} & X \otimes (A \circ (Y \oplus Z)) \\
\downarrow A \circ d_{\oplus}^{\otimes'} & & \downarrow X \otimes d_{\oplus}^{\circ} \\
A \circ (Y \oplus (X \otimes Z)) & \xrightarrow{d_{\oplus}^{\circ}} & (A \circ Y) \oplus (X \otimes Z) \\
& & \downarrow d_{\oplus}^{\circ'} \\
& & (A \circ Y) \oplus (X \otimes Z)
\end{array}
\qquad
\begin{array}{ccc}
A \circ (X \otimes (Y \oplus Z)) & \xrightarrow{a_{\otimes'}^{\circ}} & X \otimes (A \circ (Y \oplus Z)) \\
\downarrow A \circ d_{\oplus}^{\otimes} & & \downarrow X \otimes d_{\oplus}^{\circ'} \\
A \circ ((X \otimes Y) \oplus Z) & \xrightarrow{d_{\oplus}^{\circ'}} & (X \otimes Y) \oplus (A \circ Z) \\
& & \downarrow d_{\oplus}^{\otimes} \\
& & (X \otimes Y) \oplus (A \circ Z)
\end{array}$$

$$\begin{array}{ccc}
(A \bullet Y) \otimes (Z \oplus X) & \xrightarrow{d_{\oplus}^{\otimes}} & ((A \bullet Y) \otimes Z) \oplus X \\
\downarrow d_{\otimes}^{\bullet} & & \downarrow d_{\otimes}^{\bullet} \oplus X \\
A \bullet (Y \otimes (Z \oplus X)) & \xrightarrow{A \bullet d_{\oplus}^{\otimes}} & A \bullet ((Y \otimes Z) \oplus X) \\
& & \downarrow a_{\oplus}^{\bullet} \\
& & (A \bullet (Y \otimes Z)) \oplus X
\end{array}
\qquad
\begin{array}{ccc}
(Z \oplus X) \otimes (A \bullet Y) & \xrightarrow{d_{\oplus}^{\otimes'}} & (Z \otimes (A \bullet Y)) \oplus X \\
\downarrow d_{\otimes}^{\bullet'} & & \downarrow d_{\otimes}^{\bullet'} \oplus X \\
A \bullet ((Z \oplus X) \otimes Y) & \xrightarrow{A \bullet d_{\oplus}^{\otimes'}} & A \bullet ((Z \otimes Y) \oplus X) \\
& & \downarrow a_{\oplus}^{\bullet} \\
& & (A \bullet (Z \otimes Y)) \oplus X
\end{array}$$

$$\begin{array}{ccc}
(A \bullet Y) \otimes (X \oplus Z) & \xrightarrow{d_{\oplus}^{\otimes'}} & X \oplus ((A \bullet Y) \otimes Z) \\
\downarrow d_{\otimes}^{\bullet} & & \downarrow X \oplus d_{\otimes}^{\bullet} \\
A \bullet (Y \otimes (X \oplus Z)) & \xrightarrow{A \bullet d_{\oplus}^{\otimes'}} & A \bullet (X \oplus (Y \otimes Z)) \\
& & \downarrow a_{\oplus}^{\bullet'} \\
& & X \oplus (A \bullet (Y \otimes Z))
\end{array}
\qquad
\begin{array}{ccc}
(X \oplus Y) \otimes (A \bullet Z) & \xrightarrow{d_{\oplus}^{\otimes}} & X \oplus (Y \otimes (A \bullet Z)) \\
\downarrow d_{\otimes}^{\bullet'} & & \downarrow X \oplus d_{\otimes}^{\bullet'} \\
A \bullet ((X \oplus Y) \otimes Z) & \xrightarrow{A \bullet d_{\oplus}^{\otimes}} & A \bullet (X \oplus (Y \otimes Z)) \\
& & \downarrow a_{\oplus}^{\bullet'} \\
& & X \oplus (A \bullet (Y \otimes Z))
\end{array}$$

$$a_{\otimes}^{\circ} (d_{\oplus}^{\circ} \otimes X) d_{\otimes}^{\oplus} = (A \circ d_{\oplus}^{\oplus}) d_{\oplus}^{\circ} \quad (\text{A.71})$$

$$a_{\otimes}^{\circ} (d_{\oplus}^{\circ'} \otimes X) d_{\otimes}^{\oplus'} = (A \circ d_{\oplus}^{\oplus'}) d_{\oplus}^{\circ'} \quad (\text{A.72})$$

$$a_{\otimes'}^{\circ} (X \otimes d_{\oplus}^{\circ}) d_{\oplus}^{\otimes'} = (A \circ d_{\oplus}^{\otimes'}) d_{\oplus}^{\circ} \quad (\text{A.73})$$

$$a_{\otimes'}^{\circ} (X \otimes d_{\oplus}^{\circ'}) d_{\oplus}^{\otimes} = (A \circ d_{\oplus}^{\otimes}) d_{\oplus}^{\circ'} \quad (\text{A.74})$$

$$d_{\oplus}^{\otimes} (d_{\otimes}^{\bullet} \oplus X) a_{\oplus}^{\bullet} = d_{\otimes}^{\bullet} (A \bullet d_{\oplus}^{\otimes}) \quad (\text{A.75})$$

$$d_{\oplus}^{\otimes'} (d_{\otimes}^{\bullet'} \oplus X) a_{\oplus}^{\bullet'} = d_{\otimes}^{\bullet'} (A \bullet d_{\oplus}^{\otimes'}) \quad (\text{A.76})$$

$$d_{\oplus}^{\otimes'} (X \oplus d_{\otimes}^{\bullet}) a_{\oplus}^{\bullet'} = d_{\otimes}^{\bullet} (A \bullet d_{\oplus}^{\otimes'}) \quad (\text{A.77})$$

$$d_{\oplus}^{\otimes} (X \oplus d_{\otimes}^{\bullet'}) a_{\oplus}^{\bullet'} = d_{\otimes}^{\bullet'} (A \bullet d_{\oplus}^{\otimes}) \quad (\text{A.78})$$

$$\begin{array}{ccc}
A \circ (X \oplus (Y \oplus Z)) & \xrightarrow{A \circ a_{\oplus}} & A \circ ((X \oplus Y) \oplus Z) \\
\downarrow d_{\oplus}^{\circ} & & \downarrow d_{\oplus}^{\circ} \\
(A \circ X) \oplus (Y \oplus Z) & \xrightarrow{a_{\oplus}} & ((A \circ X) \oplus Y) \oplus Z
\end{array}
\quad
\begin{array}{ccc}
((A \bullet X) \otimes Y) \otimes Z & \xrightarrow{d_{\otimes}^{\bullet} \otimes Z} & (A \bullet (X \otimes Y)) \otimes Z \\
\downarrow a_{\otimes} & & \downarrow d_{\otimes}^{\bullet} \\
(A \bullet X) \otimes (Y \otimes Z) & \xrightarrow{d_{\otimes}^{\bullet}} & A \bullet ((X \otimes Y) \otimes Z)
\end{array}$$

$$\begin{array}{ccc}
A \circ ((Z \oplus Y) \otimes X) & \xrightarrow{A \circ a_{\oplus}^{-1}} & A \circ (Z \oplus (Y \oplus X)) \\
\downarrow d_{\oplus'}^{\circ} & & \downarrow d_{\oplus'}^{\circ} \\
(Z \oplus Y) \oplus (A \circ X) & \xrightarrow{a_{\oplus}^{-1}} & Z \oplus (Y \oplus (A \circ X))
\end{array}
\quad
\begin{array}{ccc}
Z \otimes (X \otimes (A \bullet Y)) & \xrightarrow{Z \otimes d_{\otimes'}^{\bullet}} & Z \otimes (A \bullet (X \otimes Y)) \\
\downarrow a_{\otimes}^{-1} & & \downarrow d_{\otimes'}^{\bullet} \\
(Z \otimes X) \otimes (A \bullet Y) & \xrightarrow{d_{\otimes'}^{\bullet}} & A \bullet (Z \otimes (X \otimes Y))
\end{array}$$

$$\begin{array}{ccc}
(X \otimes (A \bullet Y)) \otimes Z & \xrightarrow{d_{\otimes'}^{\bullet} \otimes Z} & (A \bullet (X \otimes Y)) \otimes Z \\
\downarrow a_{\otimes} & & \downarrow d_{\otimes}^{\bullet} \\
X \otimes ((A \bullet Y) \otimes Z) & & A \bullet ((X \otimes Y) \otimes Z) \\
\downarrow X \otimes d_{\otimes'}^{\bullet} & & \downarrow A \bullet a_{\otimes} \\
X \otimes (A \bullet (Y \otimes Z)) & \xrightarrow{d_{\otimes'}^{\bullet}} & A \bullet (X \otimes (Y \otimes Z))
\end{array}$$

$$(A \circ a_{\oplus}) d_{\oplus}^{\circ} (d_{\oplus}^{\circ} \oplus Z) = d_{\oplus}^{\circ} a_{\oplus} \quad (\text{A.79})$$

$$(d_{\otimes}^{\bullet} \otimes Z) d_{\otimes}^{\bullet} (A \bullet a_{\otimes}) = a_{\otimes} d_{\otimes}^{\bullet} \quad (\text{A.80})$$

$$(A \circ a_{\oplus}^{-1}) d_{\oplus'}^{\circ} (Z \oplus d_{\oplus'}^{\circ}) = d_{\oplus'}^{\circ} a_{\oplus}^{-1} \quad (\text{A.81})$$

$$(Z \otimes d_{\otimes'}^{\bullet}) d_{\otimes'}^{\bullet} (A \bullet a_{\otimes}^{-1}) = a_{\otimes}^{-1} d_{\otimes'}^{\bullet} \quad (\text{A.82})$$

$$(d_{\otimes'}^{\bullet} \otimes Z) d_{\otimes}^{\bullet} (A \bullet a_{\otimes}) = a_{\otimes} (X \otimes d_{\otimes}^{\bullet}) d_{\otimes'}^{\bullet} \quad (\text{A.83})$$

$$\begin{array}{ccc}
(A * B) \circ (X \oplus Y) & \xrightarrow{a_{\circ}^*} & A \circ (B \circ (X \oplus Y)) \\
\downarrow a_{\circ}^{*'} & & \downarrow A \circ d_{\oplus'}^{\circ} \\
B \circ (A \circ (X \oplus Y)) & & A \circ (X \oplus (B \circ Y)) \\
\downarrow B \circ d_{\oplus}^{\circ} & & \downarrow d_{\oplus}^{\circ} \\
B \circ ((A \circ X) \oplus Y) & \xrightarrow{d_{\oplus'}^{\circ}} & (A \circ X) \oplus (B \circ Y)
\end{array}
\quad
\begin{array}{ccc}
(A \bullet (X \otimes Y)) \otimes (B \bullet Z) & \xrightarrow{d_{\otimes}^{\bullet}} & A \bullet ((X \otimes Y) \otimes (B \bullet Z)) \\
\downarrow d_{\otimes'}^{\bullet} & & \downarrow A \bullet d_{\otimes'}^{\bullet} \\
B \bullet ((A \bullet (X \otimes Y)) \otimes Z) & & A \bullet (B \bullet ((X \otimes Y) \otimes Z)) \\
\downarrow B \bullet d_{\otimes}^{\bullet} & & \downarrow a_{\circ}^* \\
B \bullet (A \bullet ((X \otimes Y) \otimes Z)) & \xrightarrow{a_{\circ}^{*'}} & (A * B) \bullet ((X \otimes Y) \otimes Z)
\end{array}$$

$$\begin{array}{ccc}
(A * B) \circ (X \oplus Y) & \xrightarrow{a_{\circ}^*} & A \circ (B \circ (X \oplus Y)) \\
a_{\circ}^{*'} \downarrow & & \downarrow A \circ d_{\oplus}^{\circ} \\
B \circ (A \circ (X \oplus Y)) & & A \circ ((B \circ X) \oplus Y) \\
B \circ d_{\oplus}^{\circ} \downarrow & & \downarrow d_{\oplus}^{\circ} \\
B \circ (X \oplus (A \circ Y)) & \xrightarrow{d_{\oplus}^{\circ}} & (B \circ X) \oplus (A \circ Y)
\end{array}$$

$$\begin{array}{ccc}
(B \bullet Z) \otimes (A \bullet (X \otimes Y)) & \xrightarrow{d_{\otimes}^{\bullet}} & A \bullet ((B \bullet Z) \otimes (X \otimes Y)) \\
d_{\otimes}^{\bullet} \downarrow & & \downarrow A \bullet d_{\otimes}^{\bullet} \\
B \bullet (Z \otimes (A \bullet (X \otimes Y))) & & A \bullet (B \bullet (Z \otimes (X \otimes Y))) \\
B \bullet d_{\otimes}^{\bullet} \downarrow & & \downarrow a_{\bullet}^* \\
B \bullet (A \bullet (Z \otimes (X \otimes Y))) & \xrightarrow{a_{\bullet}^{*'}} & (A * B) \bullet (Z \otimes (X \otimes Y))
\end{array}$$

$$a_{\circ}^* (A \circ d_{\oplus}^{\circ}) d_{\oplus}^{\circ} = a_{\circ}^{*'} (B \circ d_{\oplus}^{\circ}) d_{\oplus}^{\circ} \quad (\text{A.84})$$

$$d_{\otimes}^{\bullet} (A \bullet d_{\otimes}^{\bullet}) a_{\bullet}^* = d_{\otimes}^{\bullet} (B \bullet d_{\otimes}^{\bullet}) a_{\bullet}^{*'} \quad (\text{A.85})$$

$$a_{\circ}^* (A \circ d_{\oplus}^{\circ}) d_{\oplus}^{\circ} = a_{\circ}^{*'} (B \circ d_{\oplus}^{\circ}) d_{\oplus}^{\circ} \quad (\text{A.86})$$

$$d_{\otimes}^{\bullet} (A \bullet d_{\otimes}^{\bullet}) a_{\bullet}^* = d_{\otimes}^{\bullet} (B \bullet d_{\otimes}^{\bullet}) a_{\bullet}^{*'} \quad (\text{A.87})$$

$$\begin{array}{ccc}
A \circ ((B \bullet X) \otimes Y) & \xrightarrow{a_{\otimes}^{\circ}} & (A \circ (B \bullet X)) \otimes Y \\
A \circ d_{\otimes}^{\bullet} \downarrow & & \downarrow d_{\otimes}^{\circ} \otimes Y \\
A \circ (B \bullet (X \otimes Y)) & & (B \bullet (A \circ X)) \otimes Y \\
d_{\otimes}^{\circ} \downarrow & & \downarrow d_{\otimes}^{\circ} \\
B \bullet (A \circ (X \otimes Y)) & \xrightarrow{B \bullet a_{\otimes}^{\circ}} & B \bullet ((A \circ X) \otimes Y)
\end{array}$$

$$\begin{array}{ccc}
A \circ (Y \otimes (B \bullet X)) & \xrightarrow{a_{\otimes}^{\circ}} & Y \otimes (A \circ (B \bullet X)) \\
A \circ d_{\otimes}^{\bullet} \downarrow & & \downarrow Y \otimes d_{\otimes}^{\circ} \\
A \circ (B \bullet (Y \otimes X)) & & Y \otimes (B \bullet (A \circ X)) \\
d_{\otimes}^{\circ} \downarrow & & \downarrow d_{\otimes}^{\circ} \\
B \bullet (A \circ (Y \otimes X)) & \xrightarrow{B \bullet a_{\otimes}^{\circ}} & B \bullet (Y \otimes (A \circ X))
\end{array}$$

$$\begin{array}{ccc}
B \circ ((A \bullet X) \oplus Y) & \xrightarrow{d_{\oplus}^{\circ}} & (B \circ (A \bullet X)) \oplus Y \\
B \circ a_{\oplus}^{\bullet} \downarrow & & \downarrow d_{\oplus}^{\circ} \oplus Y \\
B \circ (A \bullet (X \oplus Y)) & & (A \bullet (B \circ X)) \oplus Y \\
d_{\oplus}^{\circ} \downarrow & & \downarrow a_{\oplus}^{\bullet} \\
A \bullet (B \circ (X \oplus Y)) & \xrightarrow{A \bullet d_{\oplus}^{\circ}} & A \bullet ((B \circ X) \oplus Y)
\end{array}$$

$$\begin{array}{ccc}
B \circ (Y \oplus (A \bullet X)) & \xrightarrow{d_{\oplus}^{\circ}} & Y \oplus (B \circ (A \bullet X)) \\
B \circ a_{\oplus}^{\bullet} \downarrow & & \downarrow Y \oplus d_{\oplus}^{\circ} \\
B \circ (A \bullet (Y \oplus X)) & & Y \oplus (A \bullet (B \circ X)) \\
d_{\oplus}^{\circ} \downarrow & & \downarrow a_{\oplus}^{\bullet} \\
A \bullet (B \circ (Y \oplus X)) & \xrightarrow{A \bullet d_{\oplus}^{\circ}} & A \bullet (Y \oplus (B \circ X))
\end{array}$$

$$a_{\otimes}^{\circ} (d_{\otimes}^{\circ} \otimes Y) d_{\otimes}^{\circ} = (A \circ d_{\otimes}^{\bullet}) d_{\otimes}^{\circ} (B \bullet a_{\otimes}^{\circ}) \quad (\text{A.88})$$

$$a_{\otimes}^{\circ} (Y \otimes d_{\otimes}^{\circ}) d_{\otimes}^{\circ} = (A \circ d_{\otimes}^{\bullet}) d_{\otimes}^{\circ} (B \bullet a_{\otimes}^{\circ}) \quad (\text{A.89})$$

$$d_{\oplus}^{\circ} (d_{\oplus}^{\circ} \oplus Y) a_{\oplus}^{\bullet} = (B \circ a_{\oplus}^{\bullet}) d_{\oplus}^{\circ} (A \bullet d_{\oplus}^{\circ}) \quad (\text{A.90})$$

$$d_{\oplus}^{\circ} (Y \oplus d_{\oplus}^{\circ}) a_{\oplus}^{\bullet} = (B \circ a_{\oplus}^{\bullet}) d_{\oplus}^{\circ} (A \bullet d_{\oplus}^{\circ}) \quad (\text{A.91})$$

$$\begin{array}{ccc}
A \circ ((B \bullet X) \oplus Y) & \xrightarrow{d_{\oplus}^{\circ}} & (A \circ (B \bullet X)) \oplus Y \\
A \circ d_{\oplus}^{\bullet} \downarrow & & \downarrow d_{\oplus}^{\circ} \oplus Y \\
A \circ (B \bullet (X \oplus Y)) & & (B \bullet (A \circ X)) \oplus Y \\
d_{\oplus}^{\circ} \downarrow & & \downarrow a_{\oplus}^{\bullet} \\
B \bullet (A \circ (X \oplus Y)) & \xrightarrow{B \bullet d_{\oplus}^{\circ}} & B \bullet ((A \circ X) \oplus Y)
\end{array}
\qquad
\begin{array}{ccc}
A \circ (Y \oplus (B \bullet X)) & \xrightarrow{d_{\oplus'}^{\circ}} & Y \oplus (A \circ (B \bullet X)) \\
A \circ d_{\oplus'}^{\bullet} \downarrow & & \downarrow Y \oplus d_{\oplus'}^{\circ} \\
A \circ (B \bullet (Y \oplus X)) & & Y \oplus (B \bullet (A \circ X)) \\
d_{\oplus'}^{\circ} \downarrow & & \downarrow a_{\oplus'}^{\bullet} \\
B \bullet (A \circ (Y \oplus X)) & \xrightarrow{B \bullet d_{\oplus'}^{\circ}} & B \bullet (Y \oplus (A \circ X))
\end{array}$$

$$\begin{array}{ccc}
B \circ ((A \bullet X) \otimes Y) & \xrightarrow{a_{\otimes}^{\circ}} & (B \circ (A \bullet X)) \otimes Y \\
B \circ d_{\otimes}^{\bullet} \downarrow & & \downarrow d_{\otimes}^{\circ} \otimes Y \\
B \circ (A \bullet (X \otimes Y)) & & (A \bullet (B \circ X)) \otimes Y \\
d_{\otimes}^{\circ} \downarrow & & \downarrow d_{\otimes}^{\bullet} \\
A \bullet (B \circ (X \otimes Y)) & \xrightarrow{A \bullet a_{\otimes}^{\circ}} & A \bullet ((B \circ X) \otimes Y)
\end{array}
\qquad
\begin{array}{ccc}
B \circ (Y \otimes (A \bullet X)) & \xrightarrow{a_{\otimes'}^{\circ}} & Y \otimes (B \circ (A \bullet X)) \\
B \circ d_{\otimes'}^{\bullet} \downarrow & & \downarrow Y \otimes d_{\otimes'}^{\circ} \\
B \circ (A \bullet (Y \otimes X)) & & Y \otimes (A \bullet (B \circ X)) \\
d_{\otimes'}^{\circ} \downarrow & & \downarrow d_{\otimes'}^{\bullet} \\
A \bullet (B \circ (Y \otimes X)) & \xrightarrow{A \bullet a_{\otimes'}^{\circ}} & A \bullet (Y \otimes (B \circ X))
\end{array}$$

$$d_{\oplus}^{\circ} (d_{\oplus}^{\circ} \oplus Y) a_{\oplus}^{\bullet} = (A \circ a_{\oplus}^{\bullet}) d_{\oplus}^{\circ} (B \bullet d_{\oplus}^{\circ}) \quad (\text{A.92})$$

$$d_{\oplus'}^{\circ} (Y \oplus d_{\oplus'}^{\circ}) a_{\oplus'}^{\bullet} = (A \circ a_{\oplus'}^{\bullet}) d_{\oplus'}^{\circ} (B \bullet d_{\oplus'}^{\circ}) \quad (\text{A.93})$$

$$a_{\otimes}^{\circ} (d_{\otimes}^{\circ} \otimes Y) d_{\otimes}^{\bullet} = (B \circ d_{\otimes}^{\bullet}) d_{\otimes}^{\circ} (A \bullet a_{\otimes}^{\circ}) \quad (\text{A.94})$$

$$a_{\otimes'}^{\circ} (Y \otimes d_{\otimes'}^{\circ}) d_{\otimes'}^{\bullet} = (B \circ d_{\otimes'}^{\bullet}) d_{\otimes'}^{\circ} (A \bullet a_{\otimes'}^{\circ}) \quad (\text{A.95})$$

Unit and counit: The following diagrams must commute for unit and counit.

$$\begin{array}{ccc}
X & \xrightarrow{n_{I,X}} & I \bullet (I \circ X) \\
u_{\bullet} \downarrow & \swarrow I \bullet u_{\circ} & \\
I \circ X & & X
\end{array}
\qquad
\begin{array}{ccc}
I \circ X & \xrightarrow{I \circ u_{\bullet}} & I \circ (I \bullet X) \\
u_{\circ} \downarrow & \swarrow e_{I,X} & \\
X & & I \bullet X
\end{array}
\qquad
\begin{array}{ccc}
I \circ (I \bullet X) & \xrightarrow{e_{I,X}} & X \\
u_{\circ} \downarrow & \swarrow u_{\bullet} & \\
I \bullet X & & X
\end{array}$$

$$n_{I,X} (I \bullet u_{\circ}) = u_{\bullet} \quad (\text{A.96})$$

$$(I \circ u_{\bullet}) e_{I,X} = u_{\circ} \quad (\text{A.97})$$

$$e_{I,X} u_{\bullet} = u_{\circ} \quad (\text{A.98})$$

$$\begin{array}{ccc}
X & \xrightarrow{n_{A \bullet B, X}} & (A \bullet B) \bullet ((A \bullet B) \circ X) \\
n_{A, X} \downarrow & & \downarrow (A \bullet B) \bullet a_{\circ}^{\bullet'} \\
(A \bullet (A \circ X)) & & (A \bullet B) \bullet (B \circ (A \circ X)) \\
A \bullet n_{B, A \circ X} \downarrow & & \downarrow a_{\bullet}^{\circ} \\
A \bullet (B \bullet (B \circ (A \circ X))) & \xrightarrow{a_{\bullet}^{\circ}} & (A \bullet B) \bullet (B \circ (A \circ X))
\end{array}
\qquad
\begin{array}{ccc}
(A \bullet B) \circ (B \bullet (A \bullet X)) & \xrightarrow{(A \bullet B) \circ a_{\bullet}^{\bullet'}} & (A \bullet B) \circ ((A \bullet B) \bullet X) \\
a_{\circ}^{\bullet} \downarrow & & \downarrow e_{A \bullet B, X} \\
A \circ (B \circ (B \bullet (A \bullet X))) & & X \\
A \circ e_{B, A \bullet X} \downarrow & & \downarrow e_{A, X} \\
A \circ (A \bullet X) & \xrightarrow{e_{A, X}} & X
\end{array}$$

$$n_{A*B,X} (A * B) \bullet a_{\circ}^{*'} = n_{A,X} A \bullet n_{B,A \circ X} \quad (\text{A.99})$$

$$(A * B) \circ a_{\bullet}^{*'} e_{A*B,X} = a_{\circ}^* A \circ e_{B,A \bullet X} \quad (\text{A.100})$$

$$\begin{array}{ccc} X \otimes Y & \xrightarrow{n_{A,X \otimes Y}} & A \bullet (A \circ (X \otimes Y)) \\ n_{A,X \otimes Y} \downarrow & & \downarrow A \bullet a_{\otimes}^{\circ} \\ (A \bullet (A \circ X)) \otimes Y & \xrightarrow{d_{\otimes}^{\bullet}} & A \bullet ((A \circ X) \otimes Y) \end{array} \quad \begin{array}{ccc} A \circ ((A \bullet X) \oplus Y) & \xrightarrow{A \circ a_{\oplus}^{\bullet}} & A \circ (A \bullet (X \oplus Y)) \\ d_{\oplus}^{\circ} \downarrow & & \downarrow e_{A,X \oplus Y} \\ (A \circ (A \bullet X)) \oplus Y & \xrightarrow{e_{A,X \oplus Y}} & X \oplus Y \end{array}$$

$$\begin{array}{ccc} Y \otimes X & \xrightarrow{n_{A,Y \otimes X}} & A \bullet (A \circ (Y \otimes X)) \\ Y \otimes n_{A,X} \downarrow & & \downarrow A \bullet a_{\otimes'}^{\circ} \\ Y \otimes (A \bullet (A \circ X)) & \xrightarrow{d_{\otimes'}^{\bullet}} & A \bullet (Y \otimes (A \circ X)) \end{array} \quad \begin{array}{ccc} A \circ (Y \oplus (A \bullet X)) & \xrightarrow{A \circ a_{\oplus'}^{\bullet}} & A \circ (A \bullet (Y \oplus X)) \\ d_{\oplus'}^{\circ} \downarrow & & \downarrow e_{A,Y \oplus X} \\ Y \oplus (A \circ (A \bullet X)) & \xrightarrow{Y \oplus e_{A,X}} & Y \oplus X \end{array}$$

$$n_{A,X \otimes Y} (A \bullet a_{\otimes}^{\circ}) = (n_{A,X} \otimes Y) d_{\otimes}^{\bullet} \quad (\text{A.101})$$

$$(A \circ a_{\oplus}^{\bullet}) e_{A,X \oplus Y} = d_{\oplus}^{\circ} (e_{A,X} \oplus Y) \quad (\text{A.102})$$

$$n_{A,Y \otimes X} (A \bullet a_{\otimes'}^{\circ}) = (Y \otimes n_{A,X}) d_{\otimes'}^{\bullet} \quad (\text{A.103})$$

$$(A \circ a_{\oplus'}^{\bullet}) e_{A,Y \oplus X} = d_{\oplus'}^{\circ} (Y \oplus e_{A,X}) \quad (\text{A.104})$$

$$\begin{array}{ccc} X \oplus Y & \xrightarrow{n_{A,X \oplus Y}} & A \bullet (A \circ (X \oplus Y)) \\ n_{A,X \oplus Y} \downarrow & & \downarrow A \bullet d_{\oplus}^{\circ} \\ (A \bullet (A \circ X)) \oplus Y & \xrightarrow{a_{\oplus}^{\bullet}} & A \bullet ((A \circ X) \oplus Y) \end{array} \quad \begin{array}{ccc} A \circ ((A \bullet X) \otimes Y) & \xrightarrow{A \circ d_{\otimes}^{\bullet}} & A \circ (A \bullet (X \otimes Y)) \\ a_{\otimes}^{\circ} \downarrow & & \downarrow e_{A,X \otimes Y} \\ (A \circ (A \bullet X)) \otimes Y & \xrightarrow{e_{A,X \otimes Y}} & X \otimes Y \end{array}$$

$$\begin{array}{ccc} Y \oplus X & \xrightarrow{n_{A,Y \oplus X}} & A \bullet (A \circ (Y \oplus X)) \\ Y \oplus n_{A,X} \downarrow & & \downarrow A \bullet d_{\oplus'}^{\circ} \\ Y \oplus (A \bullet (A \circ X)) & \xrightarrow{a_{\oplus'}^{\bullet}} & A \bullet (Y \oplus (A \circ X)) \end{array} \quad \begin{array}{ccc} A \circ (Y \otimes (A \bullet X)) & \xrightarrow{A \circ d_{\otimes'}^{\bullet}} & A \circ (A \bullet (Y \otimes X)) \\ a_{\otimes'}^{\circ} \downarrow & & \downarrow e_{A,Y \otimes X} \\ Y \otimes (A \circ (A \bullet X)) & \xrightarrow{Y \otimes e_{A,X}} & Y \otimes X \end{array}$$

$$n_{A,X \oplus Y} (A \bullet d_{\oplus}^{\circ}) = (n_{A,X} \oplus Y) a_{\oplus}^{\bullet} \quad (\text{A.105})$$

$$(A \circ d_{\otimes}^{\bullet}) e_{A,X \otimes Y} = a_{\otimes}^{\circ} (e_{A,X} \otimes Y) \quad (\text{A.106})$$

$$n_{A,Y \oplus X} (A \bullet d_{\oplus'}^{\circ}) = (Y \oplus n_{A,X}) a_{\oplus'}^{\bullet} \quad (\text{A.107})$$

$$(A \circ d_{\otimes'}^{\bullet}) e_{A,Y \otimes X} = a_{\otimes'}^{\circ} (Y \otimes e_{A,X}) \quad (\text{A.108})$$

Appendix B

Coherence Conditions for Linear Functors

For linear functors, there are four linear strengths satisfying the following coherence conditions:

$$\begin{aligned}
 l_{\otimes}^{-1} (m_{\top} \otimes 1) v_{\oplus}^R &= \bar{F}(l_{\otimes}^{-1}) \\
 r_{\otimes}^{-1} (1 \otimes m_{\top}) v_{\oplus}^L &= \bar{F}(r_{\otimes}^{-1})
 \end{aligned}$$

The above two equations are shown in the following two diagrams:

$$\begin{array}{ccc}
 \bar{F}(A) & \xrightarrow{l_{\otimes}^{-1}} & \top \otimes \bar{F}(A) \\
 \bar{F}(l_{\otimes}^{-1}) \downarrow & & \downarrow m_{\top} \otimes 1 \\
 \bar{F}(\top \otimes A) & \xleftarrow{v_{\oplus}^R} & F(\top) \otimes \bar{F}(A)
 \end{array}$$

$$\begin{array}{ccc}
 \bar{F}(A) & \xrightarrow{r_{\otimes}^{-1}} & \bar{F}(A) \otimes \top \\
 \bar{F}(r_{\otimes}^{-1}) \downarrow & & \downarrow 1 \otimes m_{\top} \\
 \bar{F}(A \otimes \top) & \xleftarrow{v_{\oplus}^L} & \bar{F}(A) \otimes F(\top)
 \end{array}$$

$$v_{\otimes}^R (n_{\perp} \oplus 1) l_{\oplus} = F(l_{\oplus})$$

$$v_{\otimes}^L (1 \oplus n_{\perp}) r_{\oplus} = F(r_{\oplus})$$

The diagrams of the above two equations are as follows:

$$\begin{array}{ccc}
 F(\perp \oplus A) & \xrightarrow{F(l_{\oplus})} & F(A) \\
 v_{\otimes}^R \downarrow & & \uparrow l_{\oplus} \\
 \bar{F}(\perp) \oplus F(A) & \xrightarrow{n_{\perp} \oplus 1} & \perp \oplus F(A)
 \end{array}$$

$$\begin{array}{ccc}
F(A \oplus \perp) & \xrightarrow{F(r_\oplus)} & F(A) \\
v_\otimes^L \downarrow & & \uparrow r_\oplus \\
F(A) \oplus \bar{F}(\perp) & \xrightarrow{1 \oplus n_\perp} & F(A) \oplus \perp
\end{array}$$

$$F(a_\oplus) v_\otimes^R (1 \oplus v_\otimes^R) = v_\otimes^R (n_\oplus \oplus 1) a_\oplus$$

$$F(a_\oplus) v_\otimes^L (1 \oplus n_\oplus) = v_\otimes^L (v_\otimes^L \oplus 1) a_\oplus$$

$$(m_\otimes \otimes 1) v_\oplus^R \bar{F}(a_\otimes) = a_\otimes (1 \otimes v_\oplus^R) v_\oplus^R$$

$$(v_\oplus^L \otimes 1) v_\oplus^L \bar{F}(a_\otimes) = a_\otimes (1 \otimes m_\otimes) v_\oplus^L$$

The above four coherence conditions can be represented by the following four diagrams:

$$\begin{array}{ccc}
F((A \oplus B) \oplus C) & \xrightarrow{F(a_\oplus)} & F(A \oplus (B \oplus C)) \\
v_\otimes^R \downarrow & & \downarrow v_\otimes^R \\
\bar{F}(A \oplus B) \oplus F(C) & & \bar{F}(A) \oplus F(B \oplus C) \\
n_\oplus \oplus 1 \downarrow & & \downarrow 1 \oplus v_\otimes^R \\
(\bar{F}(A) \oplus \bar{F}(B)) \oplus F(C) & \xrightarrow{a_\oplus} & \bar{F}(A) \oplus (\bar{F}(B) \oplus F(C))
\end{array}$$

$$\begin{array}{ccc}
F((A \oplus B) \oplus C) & \xrightarrow{F(a_\oplus)} & F(A \oplus (B \oplus C)) \\
v_\otimes^L \downarrow & & \downarrow v_\otimes^L \\
F(A \oplus B) \oplus \bar{F}(C) & & F(A) \oplus \bar{F}(B \oplus C) \\
v_\otimes^L \oplus 1 \downarrow & & \downarrow 1 \oplus n_\oplus \\
(F(A) \oplus \bar{F}(B)) \oplus \bar{F}(C) & \xrightarrow{a_\oplus} & F(A) \oplus (\bar{F}(B) \oplus \bar{F}(C))
\end{array}$$

$$\begin{array}{ccc}
(F(A) \otimes F(B)) \otimes \bar{F}(C) & \xrightarrow{m_{\otimes} \otimes 1} & F(A \otimes B) \otimes \bar{F}(C) \\
\downarrow a_{\otimes} & & \downarrow v_{\oplus}^R \\
F(A) \otimes (F(B) \otimes \bar{F}(C)) & & \bar{F}((A \otimes B) \otimes C) \\
\downarrow 1 \otimes v_{\oplus}^R & & \downarrow \bar{F}(a_{\otimes}) \\
F(A) \otimes \bar{F}(B \otimes C) & \xrightarrow{v_{\oplus}^R} & \bar{F}(A \otimes (B \otimes C))
\end{array}$$

$$\begin{array}{ccc}
(\bar{F}(A) \otimes F(B)) \otimes F(C) & \xrightarrow{v_{\oplus}^L \otimes 1} & \bar{F}(A \otimes B) \otimes F(C) \\
\downarrow a_{\otimes} & & \downarrow v_{\oplus}^L \\
\bar{F}(A) \otimes (F(B) \otimes F(C)) & & \bar{F}((A \otimes B) \otimes C) \\
\downarrow 1 \otimes m_{\otimes} & & \downarrow \bar{F}(a_{\otimes}) \\
\bar{F}(A) \otimes F(B \otimes C) & \xrightarrow{v_{\oplus}^L} & \bar{F}(A \otimes (B \otimes C))
\end{array}$$

$$F(a_{\oplus}) v_{\otimes}^R (1 \oplus v_{\otimes}^L) = v_{\otimes}^L (v_{\otimes}^R \oplus 1) a_{\oplus}$$

$$(v_{\oplus}^R \otimes 1) v_{\oplus}^L \bar{F}(a_{\otimes}) = a_{\otimes} (1 \otimes v_{\oplus}^L) v_{\oplus}^R$$

Diagrammatically, the above two equations are as follows:

$$\begin{array}{ccc}
F((A \oplus B) \oplus C) & \xrightarrow{F(a_{\oplus})} & F(A \oplus (B \oplus C)) \\
\downarrow v_{\otimes}^L & & \downarrow v_{\otimes}^R \\
F(A \oplus B) \oplus \bar{F}(C) & & \bar{F}(A) \oplus F(B \oplus C) \\
\downarrow v_{\otimes}^R \oplus 1 & & \downarrow 1 \oplus v_{\otimes}^L \\
(\bar{F}(A) \oplus F(B)) \oplus \bar{F}(C) & \xrightarrow{a_{\oplus}} & \bar{F}(A) \oplus (F(B) \oplus \bar{F}(C))
\end{array}$$

$$\begin{array}{ccc}
(F(A) \otimes \bar{F}(B)) \otimes F(C) & \xrightarrow{v_{\oplus}^R \otimes 1} & \bar{F}(A \otimes B) \otimes F(C) \\
\downarrow a_{\otimes} & & \downarrow v_{\oplus}^L \\
F(A) \otimes (\bar{F}(B) \otimes F(C)) & & \bar{F}((A \otimes B) \otimes C) \\
\downarrow 1 \otimes v_{\oplus}^L & & \downarrow \bar{F}(a_{\otimes}) \\
F(A) \otimes \bar{F}(B \otimes C) & \xrightarrow{v_{\oplus}^R} & \bar{F}(A \otimes (B \otimes C))
\end{array}$$

$$(1 \otimes v_{\otimes}^R) d_{\oplus}^{\otimes} (v_{\oplus}^R \oplus 1) = m_{\otimes} F(d_{\oplus}^{\otimes}) v_{\otimes}^R$$

$$(v_{\otimes}^L \otimes 1) d_{\oplus}^{\oplus} (1 \oplus v_{\oplus}^L) = m_{\otimes} F(d_{\oplus}^{\oplus}) v_{\otimes}^L$$

$$(1 \otimes v_{\otimes}^L) d_{\oplus}^{\otimes} (v_{\oplus}^L \oplus 1) = v_{\oplus}^L \bar{F}(d_{\oplus}^{\otimes}) n_{\oplus}$$

$$(v_{\otimes}^R \otimes 1) d_{\oplus}^{\oplus} (1 \oplus v_{\oplus}^R) = v_{\oplus}^R \bar{F}(d_{\oplus}^{\oplus}) n_{\oplus}$$

In a diagrammatic way, the above four coherence conditions are as follows:

$$\begin{array}{ccc}
F(A) \otimes F(B \oplus C) & \xrightarrow{1 \otimes v_{\otimes}^R} & F(A) \otimes (\bar{F}(B) \oplus F(C)) \\
\downarrow m_{\otimes} & & \downarrow d_{\oplus}^{\otimes} \\
F(A \otimes (B \oplus C)) & & (F(A) \otimes \bar{F}(B)) \oplus F(C) \\
\downarrow F(d_{\oplus}^{\otimes}) & & \downarrow v_{\oplus}^R \oplus 1 \\
F((A \otimes B) \oplus C) & \xrightarrow{v_{\otimes}^R} & \bar{F}(A \otimes B) \oplus F(C)
\end{array}$$

$$\begin{array}{ccc}
F(A \oplus B) \otimes F(C) & \xrightarrow{v_{\otimes}^L \otimes 1} & (F(A) \oplus \bar{F}(B)) \otimes F(C) \\
\downarrow m_{\otimes} & & \downarrow d_{\oplus}^{\oplus} \\
F((A \oplus B) \otimes C) & & F(A) \oplus (\bar{F}(B) \otimes F(C)) \\
\downarrow F(d_{\oplus}^{\oplus}) & & \downarrow 1 \oplus v_{\oplus}^L \\
F(A \oplus (B \otimes C)) & \xrightarrow{v_{\otimes}^L} & F(A) \oplus \bar{F}(B \otimes C)
\end{array}$$

$$\begin{array}{ccc}
\bar{F}(A) \otimes F(B \oplus C) & \xrightarrow{1 \otimes v_{\otimes}^L} & \bar{F}(A) \otimes (F(B) \oplus \bar{F}(C)) \\
v_{\oplus}^L \downarrow & & \downarrow d_{\oplus}^{\otimes} \\
\bar{F}(A \otimes (B \oplus C)) & & (\bar{F}(A) \otimes F(B)) \oplus \bar{F}(C) \\
\bar{F}(d_{\oplus}^{\otimes}) \downarrow & & \downarrow v_{\oplus}^L \oplus 1 \\
\bar{F}((A \otimes B) \oplus C) & \xrightarrow{n_{\oplus}} & \bar{F}(A \otimes B) \oplus \bar{F}(C)
\end{array}$$

$$\begin{array}{ccc}
F(A \oplus B) \otimes \bar{F}(C) & \xrightarrow{v_{\otimes}^R \otimes 1} & (\bar{F}(A) \oplus F(B)) \otimes \bar{F}(C) \\
v_{\oplus}^R \downarrow & & \downarrow d_{\oplus}^{\oplus} \\
\bar{F}((A \oplus B) \otimes C) & & \bar{F}(A) \oplus (F(B) \otimes \bar{F}(C)) \\
\bar{F}(d_{\oplus}^{\oplus}) \downarrow & & \downarrow 1 \oplus v_{\oplus}^R \\
\bar{F}((A \otimes B) \oplus C) & \xrightarrow{n_{\oplus}} & \bar{F}(A \otimes B) \oplus \bar{F}(C)
\end{array}$$

$$(1 \otimes v_{\otimes}^L) d_{\oplus}^{\otimes} (m_{\otimes} \oplus 1) = m_{\otimes} F(d_{\oplus}^{\otimes}) v_{\otimes}^L$$

$$(v_{\otimes}^R \otimes 1) d_{\oplus}^{\oplus} (1 \oplus m_{\otimes}) = m_{\otimes} F(d_{\oplus}^{\oplus}) v_{\otimes}^R$$

$$(1 \otimes n_{\oplus}) d_{\oplus}^{\otimes} (v_{\oplus}^R \oplus 1) = v_{\oplus}^R \bar{F}(d_{\oplus}^{\otimes}) n_{\oplus}$$

$$(n_{\oplus} \otimes 1) d_{\oplus}^{\oplus} (1 \oplus v_{\oplus}^L) = v_{\oplus}^L \bar{F}(d_{\oplus}^{\oplus}) n_{\oplus}$$

The following four diagrams illustrates the above four equations:

$$\begin{array}{ccc}
F(A) \otimes F(B \oplus C) & \xrightarrow{1 \otimes v_{\otimes}^L} & F(A) \otimes (\bar{F}(B) \oplus \bar{F}(C)) \\
m_{\otimes} \downarrow & & \downarrow d_{\oplus}^{\otimes} \\
F(A \otimes (B \oplus C)) & & (F(A) \otimes F(B)) \oplus \bar{F}(C) \\
F(d_{\oplus}^{\otimes}) \downarrow & & \downarrow m_{\otimes} \oplus 1 \\
F((A \otimes B) \oplus C) & \xrightarrow{v_{\otimes}^L} & \bar{F}(A \otimes B) \oplus \bar{F}(C)
\end{array}$$

$$\begin{array}{ccc}
F(A \oplus B) \otimes F(C) & \xrightarrow{v_{\otimes}^R \otimes 1} & (F(A) \oplus F(B)) \otimes F(C) \\
\downarrow m_{\otimes} & & \downarrow d_{\otimes}^{\oplus} \\
F((A \oplus B) \otimes C) & & \bar{F}(A) \oplus (F(B) \otimes F(C)) \\
\downarrow F(d_{\otimes}^{\oplus}) & & \downarrow 1 \oplus m_{\otimes} \\
F(A \oplus (B \otimes C)) & \xrightarrow{v_{\otimes}^R} & \bar{F}(A) \oplus F(B \otimes C)
\end{array}$$

$$\begin{array}{ccc}
F(A) \otimes \bar{F}(B \oplus C) & \xrightarrow{1 \otimes n_{\oplus}} & F(A) \otimes (\bar{F}(B) \oplus \bar{F}(C)) \\
\downarrow v_{\oplus}^R & & \downarrow d_{\oplus}^{\otimes} \\
\bar{F}(A \otimes (B \oplus C)) & & (F(A) \otimes \bar{F}(B)) \oplus \bar{F}(C) \\
\downarrow \bar{F}(d_{\oplus}^{\otimes}) & & \downarrow v_{\oplus}^R \oplus 1 \\
\bar{F}((A \otimes B) \oplus C) & \xrightarrow{n_{\oplus}} & \bar{F}(A \otimes B) \oplus \bar{F}(C)
\end{array}$$

$$\begin{array}{ccc}
\bar{F}(A \oplus B) \otimes F(C) & \xrightarrow{n_{\oplus} \otimes 1} & (\bar{F}(A) \oplus \bar{F}(B)) \otimes F(C) \\
\downarrow v_{\oplus}^L & & \downarrow d_{\otimes}^{\oplus} \\
\bar{F}((A \oplus B) \otimes C) & & \bar{F}(A) \oplus (\bar{F}(C) \otimes \bar{F}(C)) \\
\downarrow \bar{F}(d_{\otimes}^{\oplus}) & & \downarrow 1 \oplus v_{\oplus}^L \\
\bar{F}(A \oplus (B \otimes C)) & \xrightarrow{n_{\oplus}} & \bar{F}(A) \oplus \bar{F}(B \otimes C)
\end{array}$$

In the symmetric case,

$$v_{\otimes}^R c_{\oplus} = F(c_{\oplus}) v_{\otimes}^L$$

$$\begin{array}{ccc}
F(A \oplus B) & \xrightarrow{v_{\otimes}^R} & \bar{F}(A) \oplus F(B) \\
\downarrow F(c_{\oplus}) & & \downarrow c_{\oplus} \\
F(B \oplus A) & \xrightarrow{v_{\otimes}^L} & F(B) \oplus \bar{F}(A)
\end{array}$$